

Constraints Guide

UG625 (v. 13.2) July 6, 2011



Xilinx is disclosing this user guide, manual, release note, and/or specification (the “Documentation”) to you solely for use in the development of designs to operate with Xilinx hardware devices. You may not reproduce, distribute, republish, download, display, post, or transmit the Documentation in any form or by any means including, but not limited to, electronic, mechanical, photocopying, recording, or otherwise, without the prior written consent of Xilinx. Xilinx expressly disclaims any liability arising out of your use of the Documentation. Xilinx reserves the right, at its sole discretion, to change the Documentation without notice at any time. Xilinx assumes no obligation to correct any errors contained in the Documentation, or to advise you of any corrections or updates. Xilinx expressly disclaims any liability in connection with technical support or assistance that may be provided to you in connection with the Information.

THE DOCUMENTATION IS DISCLOSED TO YOU “AS-IS” WITH NO WARRANTY OF ANY KIND. XILINX MAKES NO OTHER WARRANTIES, WHETHER EXPRESS, IMPLIED, OR STATUTORY, REGARDING THE DOCUMENTATION, INCLUDING ANY WARRANTIES OF MERCHANTABILITY, FITNESS FOR A PARTICULAR PURPOSE, OR NONINFRINGEMENT OF THIRD-PARTY RIGHTS. IN NO EVENT WILL XILINX BE LIABLE FOR ANY CONSEQUENTIAL, INDIRECT, EXEMPLARY, SPECIAL, OR INCIDENTAL DAMAGES, INCLUDING ANY LOSS OF DATA OR LOST PROFITS, ARISING FROM YOUR USE OF THE DOCUMENTATION.

© Copyright 2002-2011 Xilinx Inc. All Rights Reserved. XILINX, the Xilinx logo, the Brand Window and other designated brands included herein are trademarks of Xilinx, Inc. All other trademarks are the property of their respective owners. The PowerPC name and logo are registered trademarks of IBM Corp., and used under license. All other trademarks are the property of their respective owners.

Revision History

The following table shows the revision history for this document.

Date	Version	
03/01/2011	13.1	Added VCCAUX_IO and MARK_DEBUG constraints.
07/06/2011	13.2	Added Spartan®-6 to list of supported devices where appropriate. For PULLUP (Pullup) constraint, added information that NGDBuild ignores the following: • DEFAULT KEEPER = FALSE • DEFAULT PULLUP = FALSE • DEFAULT PULLDOWN = FALSE For IODELAY_GROUP (IODELAY Group) constraint, added information under Limitations with LOC and Architecture Support For Area Group (AREA_GROUP) constraint, added Note: All components can be constrained by the CLOCKREGION range except IOB and BUF. For CONFIG_MODE (Configuration Mode) constraint, added new architecture support and new values. For BEL (BEL) constraint, removed VHDL example.

Table of Contents

Revision History	2
Chapter 1 Constraint Types.....	7
Attributes and Constraints	7
CPLD Fitter.....	8
Grouping Constraints for Timing.....	9
Logical Constraints	12
Physical Constraints.....	13
Mapping Directives	14
Placement Constraints	15
Routing Directives	17
Synthesis Constraints	18
Timing Constraints	19
Configuration Constraints	23
Chapter 2 Entry Strategies for Xilinx Constraints	25
Constraints Entry Methods.....	25
Constraints Entry Table	25
Schematic Design.....	28
VHDL Attributes.....	28
Verilog Attributes.....	29
User Constraints File (UCF).....	31
UCF and NCF File Syntax.....	32
Physical Constraints File (PCF)	36
Netlist Constraints File (NCF).....	38
Constraints Editor	38
ISE Design Suite	40
PlanAhead	40
Setting Constraints in PACE.....	44
Partial Design Pin Preassignment.....	44
FPGA Editor	46
XST Constraint File (XCF)	48
Constraint Priority	48
Chapter 3 Timing Constraint Strategies.....	51
Basic Constraints Methodology	51
Input Timing Constraints	52

Register-to-Register Timing Constraints	56
Output Timing Constraints	60
Exception Timing Constraints	64
Chapter 4 Xilinx Constraints	67
Constraint Information	67
AREA_GROUP (Area Group)	68
ASYNC_REG (Asynchronous Register).....	76
BEL (BEL).....	77
BLKNM (Block Name).....	79
BUFG (BUFG).....	81
Clock Dedicated Route (CLOCK_DEDICATED_ROUTE)	83
COLLAPSE (Collapse)	84
COMPGRP (Component Group)	85
CONFIG_MODE (Configuration Mode)	86
COOL_CLK (CoolCLOCK).....	88
DATA_GATE (Data Gate)	90
DCI Cascade (DCI_CASCADE)	92
DCI Value (DCI_VALUE)	94
Default (DEFAULT)	95
DIFF_TERM (Diff_Term).....	99
DIRECTED_ROUTING (Directed Routing)	101
DISABLE (Disable)	103
DRIVE (Drive).....	105
DROP_SPEC (Drop Specifications)	108
ENABLE (Enable).....	109
ENABLE_SUSPEND (Enable Suspend).....	111
FAST (Fast)	112
FEEDBACK (Feedback)	114
FILE (File)	116
FLOAT (Float).....	118
FROM-THRU-TO (From Thru To)	120
FROM-TO (From To).....	122
FSM_STYLE (FSM Style).....	124
HBLKNM (Hierarchical Block Name)	125
HIODELAY_GROUP (HIODELAY Group)	127
HLUTNM (Hierarchical Lookup Table Name).....	128
H_SET (H Set)	130
HU_SET (HU Set).....	131

IBUF_DELAY_VALUE (Input Buffer Delay Value).....	133
IFD_DELAY_VALUE (IFD Delay Value)	135
IN_TERM (In Term)	137
INREG (Input Registers)	139
Internal Vref Bank (INTERNAL_VREF_BANK).....	140
IOB (IOB).....	141
IOBDELAY (Input Output Block Delay)	143
IODELAY_GROUP (IODELAY Group)	145
IOSTANDARD (Input Output Standard)	147
KEEP (Keep)	150
KEEP_HIERARCHY (Keep Hierarchy).....	152
Keeper (KEEPER)	155
LOC (Location)	157
LOCATE (Locate).....	170
LOCK_PINS (Lock Pins).....	171
LUTNM (Lookup Table Name)	172
MAP (Map).....	175
MARK_DEBUG (Mark Debug).....	176
MAX_FANOUT (Max Fanout).....	178
MAXDELAY (Maximum Delay)	181
MAXPT (Maximum Product Terms)	184
MAXSKEW (Maximum Skew).....	185
MCB Performance (MCB_PERFORMANCE).....	188
MIODELAY_GROUP (MIODELAY Group).....	189
NODELAY (No Delay).....	190
NOREDUCE (No Reduce)	192
OFFSET IN (Offset In).....	194
OFFSET OUT (Offset Out)	200
Open Drain (OPEN_DRAIN)	204
OUT_TERM (Out Term)	206
PERIOD (Period).....	208
PIN (Pin)	216
Post CRC (POST_CRC).....	217
Post CRC Action (POST_CRC_ACTION)	218
Post CRC Frequency (POST_CRC_FREQ).....	219
Post CRC INIT Flag (POST_CRC_INIT_FLAG)	220
Post CRC Signal (POST_CRC_SIGNAL)	221
Post CRC Source (POST_CRC_SOURCE).....	222

PRIORITY (Priority)	223
PROHIBIT (Prohibit).....	224
PULLDOWN (Pulldown).....	227
PULLUP (Pullup)	229
PWR_MODE (Power Mode).....	231
REG (Registers)	233
RLOC (Relative Location).....	235
RLOC_ORIGIN (Relative Location Origin)	252
RLOC_RANGE (Relative Location Range).....	255
SAVE NET FLAG (Save Net Flag)	258
SCHMITT_TRIGGER (Schmitt Trigger)	260
SIM Collision Check (SIM_COLLISION_CHECK).....	262
SLEW (Slew).....	264
SLOW (Slow).....	267
STEPPING (Stepping)	269
SUSPEND (Suspend).....	270
SYSTEM_JITTER (System Jitter)	272
TEMPERATURE (Temperature)	274
TIG (Timing Ignore)	276
TIMEGRP (Timing Group).....	279
TIMESPEC (Timing Specifications)	286
TNM (Timing Name)	289
TNM_NET (Timing Name Net).....	293
TPSYNC (Timing Point Synchronization).....	297
TPTHRU (Timing Thru Points).....	300
TSIdentifier (Timing Specification Identifier)	303
U SET (U_SET)	306
Use Internal VREF (USE_INTERNAL_VREF).....	308
USE_LUTNM (Use LUTNM).....	310
USE_RLOC (Use Relative Location)	312
Use Low Skew Lines (USELOWSKEWLINES)	315
VCCAUX (VCCAUX).....	317
VCCAUX_IO	318
VOLTAGE (Voltage).....	320
VREF (VREF)	321
WIREAND (Wire And)	322
XBLKNM (XBLKNM)	323
Appendix Additional Resources	325

Constraint Types

This chapter discusses the constraint types documented in this Guide.

Attributes and Constraints

Some designers use the terms *attribute* and *constraint* interchangeably. Other designers give them different meanings. In addition, certain language constructs use the terms *attribute* and *directive* in similar, but not identical, senses. Xilinx® uses the terms *attributes* and *constraints* as defined below.

Attributes

An attribute is a property associated with a device architecture primitive component that generally affects an instantiated component functionality or implementation.

Attributes are passed by means:

- Generic maps (VHDL)
- Defparams or inline parameter passed while instantiating the primitive component (Verilog)

All attributes are described in the *Xilinx Libraries Guides* as a part of the primitive component description.

Attributes Examples

- INIT on a LUT4 component
- CLKFX_DIVIDE on a DCM

Implementation Constraints

The *Constraints Guide* documents implementation constraints.

An implementation constraint is an instruction given to the FPGA implementation tools to direct the mapping, placement, timing or other guidelines to follow while processing an FPGA design.

Implementation constraints are generally placed in the User Constraints File (UCF). They may also be placed in:

- The Hardware Description Language (HDL) code
- A synthesis constraints file.

Implementation Constraints Examples

- [LOC](#) (placement)
- [PERIOD](#) (timing)

CPLD Fitter

The following constraints apply to CPLD devices:

- BUFG (CPLD)
- Collapse (COLLAPSE)
- CoolCLOCK (COOL_CLK)
- Data Gate (DATA_GATE)
- Fast (FAST)
- Input Registers (INREG)
- Input Output Standard (IOSTANDARD)
- Keep (KEEP)
- Keeper (KEEPER)
- Location (LOC)
- Maximum Product Terms (MAXPT)
- No Reduce (NOREDUCE)
- Offset In (OFFSET IN)
- Offset Out (OFFSET OUT)
- Open Drain (OPEN_DRAIN)
- Period (PERIOD)
- Prohibit (PROHIBIT)
- Pullup (PULLUP)
- Power Mode (PWR_MODE)
- Registers (REG)
- Schmitt Trigger (SCHMITT_TRIGGER)
- Slow (SLOW)
- Timing Group (TIMEGRP)
- Timing Specifications (TIMESPEC)
- Timing Name (TNM)
- Timing Specification Identifier (TSidentifier)
- VREF
- Wire And (WIREAND)

Grouping Constraints for Timing

For a [Timing Specifications](#) constraint, specify the set of paths to be analyzed by grouping start and end points in one of the following ways.

- Refer to a predefined group by specifying one of the corresponding keywords: CPUS, DSPS, FFS, HSIOs, LATCHES, MULTS, PADS, RAMS, BRAMS_PORTA, or BRAMS_PORTB.
- Create your own groups within a predefined group by tagging symbols with [Timing Name](#) and [Timing Name Net](#) constraints.
- Create groups that are combinations of existing groups using [Timing Group](#) symbols.
- Create groups by pattern matching on net names.

For more information, see [Creating Groups by Pattern Matching in the Timing Group](#) constraint.

Using Predefined Groups

Using predefined groups, you can refer to a group of flip-flops, input latches, pads, or RAMs by using the corresponding keywords.

Predefined Groups Keywords

Keyword	Description
CPUS	PPC405 in Virtex®-4 FX devices
DSPS	DSP48 and any DSP48 derivative in Virtex-4 devices, Virtex-5 devices, and Spartan®-3A Extended devices CPUS in Virtex-5 FXT devices
FFS	All CLB and IOB edge-triggered flip-flops and Shift Register LUTs (all devices have shift register LUTs)
HSIOs	GT11 (Virtex-4 devices), GTP_DUAL (Virtex-5 devices) and GTX_DUAL (Virtex-5 FXT devices)
LATCHES	All CLB and IOB level-sensitive latches
MULTS	Synchronous and asynchronous multipliers.
PADS	All I/O pads (typically inferred from top level HDL ports)
RAMS	<ul style="list-style-type: none"> – All CLB LUT RAMs, both single- and dual-port (includes both ports of dual-port) – All block RAMs, both single- and dual-port (includes both ports of dual-port) – FIFOS – All FIFO (First In, First Out) Block RAM Memory
BRAMS_PORTA	Port A of all dual-port block RAMs
BRAMS_PORTB	Port B of all dual-port block RAMs

Predefined Group Examples

From-To statements enable you to define timing specifications for paths between predefined groups. The following examples are TS constraints that are entered in the UCF. This method enables you to easily define default timing specifications, as illustrated by the following examples.

Following is a UCF syntax example.

```
TIMESPEC "TS01"=FROM FFS TO FFS 30;
```

```
TIMESPEC "TS02"=FROM LATCHES TO LATCHES 25;
```

```
TIMESPEC "TS03"=FROM PADS TO RAMS 70;
```

```
TIMESPEC "TS04"=FROM FFS TO PADS 55;
```

```
TIMESPEC "TS01" = FROM BRAMS_PORTA TO BRAMS_PORTB(gork*);
```

For BRAMS_PORTA and BRAMS_PORTB, the specification TS01 controls paths that begin at any A port and end at a B port, which drives a signal matching the pattern **gork***.

BRAMS_PORTA and BRAMS_PORTB Examples

Following are additional examples of BRAMS_PORTA and BRAMS_PORTB.

```
NET "X" TNM_NET = BRAMS_PORTA groupA;
```

The TNM group groupA contains all A ports that are driven by net X. If net X is traced forward into any B port inputs, any single-port block RAM elements, or any Select RAM elements, these do not become members of groupA.

```
NET "X" TNM_NET = BRAMS_PORTB( dob* ) groupB;
```

The TNM group groupB contains each B port driven by net X, if at least one output on that B port drives a signal matching the pattern dob*.

```
INST "Y" TNM = BRAMS_PORTB groupC;
```

The TNM group groupC contains all B ports found under instance Y. If instance Y is itself a dual-port block RAM primitive, then groupC contains the B port of that instance.

```
INST "Y" TNM = BRAMS_PORTA( doa* ) groupD;
```

The TNM group groupD contains each A port found under instance Y, if at least one output on that A port drives a signal matching the pattern doa*.

```
TIMEGRP "groupE" = BRAMS_PORTA;
```

The user group groupE contains the A ports of all dual-port block RAM elements. This is equivalent to BRAMS_PORTA (*).

```
TIMEGRP "groupF" = BRAMS_PORTB( mem/dob* );
```

The user group groupF contains all B ports, which drives a signal matching the pattern mem/dob*.

A predefined group can also carry a name qualifier. The qualifier can appear any place the predefined group is used. This name qualifier restricts the number of elements referred to. The syntax is:

```
predefined group (name_qualifier [ name_qualifier ])
```

name_qualifier is the full hierarchical name of the net that is sourced by the primitive being identified.

The name qualifier can include the following wildcard characters:

- An asterisk (*) to show any number of characters
- A question mark (?) to show a single character

Wildcard characters allow you to:

- Specify more than one net
- Shorten and simplify the full hierarchical name

For example, specifying the group FFS (MACRO_A/Q?) selects only the flip-flops driving the Q0, Q1, Q2 and Q3 nets.

Grouping Constraints

- [Component Group \(COMPGRP\)](#)
- [Pin \(PIN\)](#)
- [Timing Group \(TIMEGRP\)](#)
- [Timing Name \(TNM\)](#)
- [Timing Name Net \(TNM_NET\)](#)
- [Timing Point Synchronization \(TPSYNC\)](#)
- [Timing Thru Points \(TPTHURU\)](#)

Logical Constraints

Logical constraints are constraints that are attached to elements before mapping or fitting.

- Logical constraints help adapt design performance to expected worst-case conditions.
- Logical constraints are converted into physical constraints when you:
 1. Choose a specific Xilinx® architecture, and
 2. Place and Route, or fit, the design.
- You can attach logical constraints using attributes in the input design, which are written into the Netlist Constraints File (NCF) or NGC netlist, or with a User Constraints File (UCF).
- Three categories of logical constraints are:
 - [Placement Constraints](#)
 - [Relative Location Constraints](#)

For FPGA devices, Relative Location constraints:

- ◆ Group logic elements into discrete sets.
- ◆ Allow you to define the location of any element within the set relative to other elements in the set, regardless of eventual placement in the overall design.
- [Timing Constraints](#)

Timing constraints allow you to specify the maximum allowable delay or skew on any given set of paths or nets.

Physical Constraints

Note This section applies to FPGA devices only.

Physical constraints are constraints attached to the elements in the physical design.

Mapping

- The physical design is the design after it has been mapped.
- When a design is mapped, the *logical* constraints in (1) the netlist, and (2) the User Constraints File (UCF), are translated into *physical* constraints that apply to a specific architecture.
- Physical constraints are defined in the Physical Constraints File (PCF) created during mapping.

Physical Constraints File (PCF)

The Physical Constraints File (PCF):

- Is a mapper-generated file.
- Contains two sections:
 - Schematic
 - Contains the physical constraints based on the logical constraints found in the netlist and the UCF.
 - User
 - ◆ Can be used to add any physical constraints.
 - ◆ Xilinx® recommends that you place user-generated constraints in a UCF, not in an NCF or a PCF.

Mapping Directives

Mapping directives instruct the mapper to perform specific operations.

Mapping Directives

- Area Group
- BEL
- Block Name
- DCI_VALUE
- Drive
- Fast
- Hierarchical Block Name
- Hierarchical Lookup Table Name
- HU SET
- IOB
- Input Output Block Delay
- Input Output Standard
- Keep
- Keeper
- Lookup Table Name
- Map
- No Delay
- Pulldown
- Pullup
- Relative Location
- Relative Location Origin
- Relative Location Range
- Save Net Flag
- Slew
- U SET
- Use Relative Location
- XBLKNM

Placement Constraints

This section describes the placement constraints for each type of logic element in FPGA designs, including:

- Flip-Flop
- ROM
- RAM
- BUFT
- CLB
- IOB
- I/O
- Edge decoder
- Global buffer

Individual logic gates such as **AND** or **OR** gates:

- Are mapped into CLB function generators before the constraints are read.
- Cannot be constrained.

Specifying Constraints

Most constraints can be specified in:

- HDL source code, or
- User Constraints File (UCF)

In a constraints file, each placement constraint acts upon one or more symbols. Every symbol in a design carries a unique name, which is defined in the input file. Use this name in a constraint statement to identify the symbol.

Case Sensitivity

- The UCF and the NCF are case sensitive.
- Identifier names (names of objects, such as net names) must exactly match the case of the name as it exists in the source design netlist.
- Xilinx® keywords (such as **LOC**, **PROHIBIT**, **RLOC**, and **BLKNM**) can be entered in all uppercase or all lowercase. Mixed case is not allowed.

Netlist Mapping and Placement Constraints

The following constraints control mapping and placement of symbols in a netlist:

- **BLKNM**
- **HBLKNM**
- **HLUTNM**
- **LOC**
- **LUTNM**
- **PROHIBIT**
- **RLOC**
- **RLOC_ORIGIN**
- **RLOC_RANGE**
- **XBLKNM**

Relative Location (RLOC) Constraints

The **RLOC** constraint groups logic elements into discrete sets.

- You can define the location of any element within the set relative to other elements in the set, regardless of eventual placement in the overall design.
- For example, if **RLOC** constraints are applied to a group of eight flip-flops organized in a column, the mapper maintains the columnar order and moves the entire group of flip-flops as a single unit.
- In contrast, absolute **LOC** constraints constrain design elements to specific locations on the FPGA die with no relation to other design elements.

Placement Constraints

- **AREA_GROUP**
- **BEL**
- **LOC**
- **LOCATE**
- **Prohibit**
- **RLOC**
- **RLOC_ORIGIN**
- **RLOC_RANGE**
- **USE_RLOC**

Routing Directives

Routing directives instruct PAR to perform specific operations.

- [AREA_GROUP](#)
- [CONFIG_MODE](#)
- [LOCK_PINS](#)

Synthesis Constraints

Synthesis constraints direct the synthesis tool optimization technique for a particular design or piece of Hardware Description Language (HDL) code. The constraints are either embedded in the source code, or are included in a separate synthesis constraints file.

The following constraints are synthesis constraints:

- [FROM-TO](#)
- [IOB](#)
- [KEEP](#)
- [MAP](#)
- [MARK_DEBUG](#)
- [OFFSET IN](#)
- [OFFSET OUT](#)
- [PERIOD](#)
- [TIG](#)
- [TNM](#)
- [TNM_NET](#)

Synthesis Constraint Documentation

XST synthesis constraints are documented in:

- *XST User Guide for Virtex-4, Virtex-5, Spartan-3, and Newer CPLD Devices (UG627)*
- *XST User Guide for Virtex-6, Spartan-6, and 7 Series Devices (UG687)*

Other synthesis constraints are documented in the software vendor's documentation.

Timing Constraints

The Xilinx® software enables you to specify precise timing requirements using either global or path-specific timing constraints.

The recommended methods for defining the constraints are discussed in [Timing Constraint Strategies](#).

Timing and Grouping Constraints

The following are timing constraints and associated grouping constraints:

- [Asynchronous Register \(ASYNC_REG\)](#)
- [Disable \(DISABLE\)](#)
- [Drop Specifications \(DROP_SPEC\)](#)
- [Enable \(ENABLE\)](#)
- [From Thru To \(FROM-THRU-TO\)](#)
- [From To \(FROM-TO\)](#)
- [Maximum Skew \(MAXSKEW\)](#)
- [Offset In \(OFFSET IN\)](#)
- [Offset Out \(OFFSET OUT\)](#)
- [Period \(PERIOD\)](#)
- [Priority \(PRIORITY\)](#)
- [System Jitter \(SYSTEM_JITTER\)](#)
- [Temperature \(TEMPERATURE\)](#)
- [Timing Ignore \(TIG\)](#)
- [Timing Group \(TIMEGRP\)](#)
- [Timing Specifications \(TIMESPEC\)](#)
- [Timing Name \(TNM\)](#)
- [Timing Name Net \(TNM_NET\)](#)
- [Timing Point Synchronization \(TPSYNC\)](#)
- [Timing Thru Points \(TPTHRU\)](#)
- [Timing Specification Identifier \(TSidentifier\)](#)
- [Voltage \(VOLTAGE\)](#)

Specifying Timing Constraints

To specify timing constraints, enter them in:

- User Constraints File (UCF) (primary method), or
- HDL source code, or
- Schematic source code.

Once you have defined the timing specifications and mapped the design, PAR places and routes the design based on these specifications.

To analyze the results of the timing specifications, use:

- Timing Analyzer (ISE® Design Suite), or
- TRACE (command line).

Independent of the way timing constraints are specified, the Clock Signal option affects timing constraint processing. In the case where a clock signal goes through which input pin is the real clock pin. The CLOCK_SIGNAL constraint allows you to define the clock pin. See the *XST User Guide for Virtex-4, Virtex-5, Spartan-3, and Newer CPLD Devices (UG627)* for more information.

Applying XST Timing Constraints

You can apply XST timing constraints by means of:

- The **-glob_opt** command line switch, OR
- The XST Constraint File (XCF)

Command Line Switch

- Using the **-glob_opt** command line switch is the same as selecting **Process Properties > Synthesis Options > Global Optimization Goal**.
- Using **-glob_opt** allows you to apply global timing constraints to the entire design.
- You cannot specify a value for these constraints.
- XST optimizes them for the best performance.
- These constraints are overridden by constraints specified in the XCF.

XST Constraint File (XCF)

Using the XCF allows you to use the native UCF timing constraint syntax. Using the XCF syntax, XST supports constraints such as:

- [TNM_NET](#)
- [TIMEGRP](#)
- [PERIOD](#)
- [TIG](#)
- [FROM-TO](#)

You can use both wildcards and hierarchical names.

Timing constraints are not written to the NGC file by default. Timing constraints are written to the NGC file only when:

- **Write Timing Constraints** is checked in ISE® Design Suite in **Process > Properties** or
- **-write_timing_constraints** option is specified in the command line.

UCF Timing Constraint Support

Note If you specify timing constraints in the XCF file, Xilinx® strongly suggests that you to use the `'/'` character as a hierarchy separator instead of `'_'`.

The following timing constraints are supported in the XCF.

From-To

FROM-TO defines a timing constraint between two groups. A group can be user-defined or predefined (FFS, PADS, RAMS). Following is an example of XCF Syntax:

```
TIMESPEC "TS name"=FROM group1 TO "group2" value ;
```

OFFSET IN

OFFSET IN specifies the timing requirements of an input interface to the FPGA device. The constraint specifies the clock and data timing relationship at the external pads of the FPGA device. An **OFFSET IN** constraint specification checks the setup and hold timing requirements of all synchronous elements associated with the constraint.

OFFSET OUT

OFFSET OUT specifies the timing requirements of an output interface from the FPGA device. The constraint specifies the time from the clock edge at the input pin of the FPGA device until data becomes valid at the output pin of the FPGA.

TIG

TIG causes all paths going through a specific net to be ignored for timing analyses and optimization purposes. This constraint can be applied to the name of the signal affected.

XCF Syntax:

```
NET "netname" TIG;
```

TIMEGRP

TIMEGRP is a basic grouping constraint. In addition to naming groups using the **TNM** identifier, you can also define groups in terms of other groups. You can create a group that is a combination of existing groups by defining a Timing Group (**TIMEGRP**) constraint.

You can place Timing Group (**TIMEGRP**) constraints in a constraints file (XCF or NCF). You can use Timing Group (**TIMEGRP**) attributes to create groups using the following methods.

- Combining multiple groups into one
- Defining flip-flop subgroups by clock sense

TNM

Timing Name (TNM) is a basic grouping constraint. Use **Timing Name (TNM)** to identify the elements that make up a group, which you can then use in a timing specification. **TNM** tags specific FFS, RAMs, LATCHES, PADS, BRAMS_PORTA, BRAMS_PORTB, CPUS, HSIOs, and MULTS as members of a group to simplify the application of timing specifications to the group.

The **RISING** and **FALLING** keywords may also be used with **Timing Name (TNM)** constraints. The XCF syntax is:

```
{NET|INST|PIN} "net_or_pin_or_inst_name" TNM=[predefined_group] identifier ;
```

TNM Net

[Timing Name Net \(TNM_NET\)](#) is essentially equivalent to TNM on a net *except* for input pad nets. Special rules apply when using TNM_NET with the [Period \(PERIOD\)](#) constraint for DLL/DCM/PLL/MMCMs in all FPGA devices

For more information, see [PERIOD Specifications on CLKDLLs, DCMs, PLLs, and MMCMs](#).

A TNM_NET is a property that you normally use in conjunction with an HDL design to tag a specific net. All downstream synchronous elements and pads tagged with the TNM_NET identifier are considered a group. For more information, see the [Timing Name \(TNM\)](#) constraint.

The XCF syntax is:

```
NET "netname" TNM_NET=[predefined_group ] identifier;
```

Timing Model

The timing model used by XST for timing analysis takes into account both logic delays and net delays. These delays are highly dependent on the speed grade that can be specified to XST. These delays are also dependent on the selected technology. Logic delays data are identical to the delays reported by TRACE (Timing Analyzer) after Place and Route). The Net delay model is estimated based on the fanout load.

Constraint Priority

Constraints are processed in the following order:

- Specific constraints on signals
- Specific constraints on top module
- Global constraints on top module

For example, constraints on two different domains or two different signals have the same priority (that is, PERIOD clk1 can be applied with PERIOD clk2).

Configuration Constraints

- [Configuration Mode \(CONFIG_MODE\)](#)
- [DCI_CASCADE](#)
- [MCB_PERFORMANCE](#)
- [Stepping \(STEPPING\)](#)
- [POST_CRC](#)
- [POST_CRC_ACTION](#)
- [POST_CRC_FREQ](#)
- [POST_CRC_INIT_FLAG](#)
- [VCCAUX](#)
- [VREF](#)
- [Internal Vref Bank](#)

Entry Strategies for Xilinx Constraints

This chapter discusses entry strategies for Xilinx® constraints, including how to use ISE® Design Suite to enter a given constraint type.

Constraints Entry Methods

The following table shows which feature of ISE® Design Suite to use to enter a given constraint type.

Constraints Entry Methods

Constraint Type	Tool	Devices
Timing	Constraints Editor	All CPLD and FPGA device families
IO placement and area-group constraints	PlanAhead™ Software	All FPGA device families
IO placement	PACE	All CPLD device families
IO placement and other placement constraints	Schematic and Symbol Editors	All CPLD and FPGA device families

Constraints Entry Table

The following table lists the constraints and their associated entry strategies. See the individual constraint for syntax examples.

Constraints Entry Table

Constraint	Schematic	VHDL Verilog	NCF	UCF	Constraints Editor	PCF	XCF	Plan-Ahead	PACE	FPGA Editor	ISE® Design Suite
AREA_GROUP	Yes		Yes	Yes	Yes			Yes			
ASYNC_REG		Yes	Yes	Yes	Yes						
BEL		Yes	Yes	Yes				Yes			
BLKMN	Yes	Yes	Yes	Yes			Yes				
BUFG (CPLD)	Yes	Yes	Yes	Yes			Yes				
CLOCK_DEDICATED_ROUTE			Yes	Yes							
COLLAPSE	Yes	Yes	Yes	Yes							
COMPGRP						Yes					

Constraint	Schematic	VHDL Verilog	NCF	UCF	Constraints Editor	PCF	XCF	Plan-Ahead	PACE	FPGA Editor	ISE® Design Suite
CONFIG_MODE				Yes							
COOL_CLK	Yes	Yes	Yes	Yes							
DATA_GATE	Yes	Yes	Yes	Yes							
DEFAULT	Yes	Yes	Yes	Yes			Yes	Yes	Yes		
DCI_CASCADE			Yes	Yes		Yes					
DCI_VALUE			Yes	Yes							
DIRECTED_ROUTING			Yes	Yes						Yes	
DISABLE			Yes	Yes		Yes					
DRIVE	Yes	Yes	Yes	Yes			Yes	Yes	Yes	Yes	
DROP_SPEC	Yes		Yes	Yes		Yes					
ENABLE			Yes	Yes		Yes					
ENABLE_SUSPEND			Yes	Yes							
FAST	Yes	Yes	Yes	Yes			Yes	Yes	Yes		
FEEDBACK				Yes	Yes	Yes	Yes	Yes			
FILE	Yes	Yes									
FLOAT	Yes	Yes	Yes	Yes			Yes				
FROM-THRU-TO			Yes	Yes	Yes	Yes		Yes			
FROM-TO			Yes	Yes	Yes	Yes	Yes	Yes			
HBLKNM	Yes	Yes	Yes	Yes							
HLUTNM	Yes	Yes	Yes	Yes	Yes		Yes				
HU_SET	Yes	Yes	Yes	Yes			Yes				
IBUF_DELAY_VALUE	Yes	Yes	Yes	Yes							
IFD_DELAY_VALUE	Yes	Yes	Yes	Yes							
INREG	Yes			Yes							
IOB	Yes	Yes	Yes	Yes			Yes				Yes
IOBDELAY	Yes	Yes	Yes	Yes	Yes						
IODELAY_GROUP				Yes							
IOSTANDARD	Yes	Yes	Yes	Yes			Yes	Yes	Yes	Yes	
KEEP	Yes	Yes	Yes	Yes			Yes				
KEEPER	Yes	Yes	Yes	Yes	Yes		Yes			Yes	
KEEP_HIERARCHY	Yes	Yes	Yes	Yes			Yes				Yes
LOC	Yes	Yes	Yes	Yes			Yes	Yes	Yes		
LOCATE							Yes			Yes	
LOCK_PINS		Yes	Yes	Yes							

Constraint	Schematic	VHDL Verilog	NCF	UCF	Constraints Editor	PCF	XCF	Plan-Ahead	PACE	FPGA Editor	ISE® Design Suite
LUTNM	Yes	Yes	Yes	Yes							
MAP	Yes		Yes	Yes							
MARK_DEBUG		Yes					Yes	Yes			
MAXDELAY	Yes	Yes	Yes	Yes	Yes	Yes				Yes	
MAX_FANOUT		Yes					Yes				Yes
MAXPT		Yes	Yes	Yes							
MAXSKEW	Yes	Yes	Yes	Yes	Yes	Yes				Yes	
NODELAY	Yes	Yes	Yes	Yes			Yes				
IODELAY_GROUP				Yes							
NOREDUCE	Yes	Yes	Yes	Yes			Yes				
OFFSET IN	Yes		Yes	Yes	Yes	Yes	Yes	Yes			
OFFSET OUT	Yes		Yes	Yes	Yes	Yes	Yes	Yes			
OPEN_DRAIN	Yes	Yes	Yes	Yes			Yes				
PERIOD	Yes	Yes	Yes	Yes	Yes	Yes	Yes	Yes		Yes	
PIN				Yes							
POST_CRC				Yes		Yes					
POST_CRC_ACTION				Yes		Yes					
POST_CRC_FREQ				Yes		Yes					
POST_CRC_INIT_FLAG				Yes		Yes					
PRIORITY			Yes	Yes		Yes					
PROHIBIT				Yes		Yes		Yes	Yes	Yes	
PULLDOWN	Yes	Yes	Yes	Yes			Yes	Yes	Yes	Yes	
PULLUP	Yes	Yes	Yes	Yes			Yes	Yes	Yes	Yes	
PWR_MODE	Yes	Yes	Yes	Yes			Yes				
REG	Yes	Yes	Yes	Yes			Yes				
RLOC	Yes	Yes	Yes	Yes			Yes	Yes			
RLOC_ORIGIN	Yes	Yes	Yes	Yes		Yes		Yes			
RLOC_RANGE	Yes	Yes	Yes	Yes		Yes	Yes				
SAVE NET FLAG	Yes	Yes	Yes	Yes			Yes				
SCHMITT_TRIGGER	Yes	Yes	Yes	Yes			Yes				
SLEW	Yes	Yes	Yes	Yes			Yes	Yes	Yes	Yes	
SLOW	Yes	Yes	Yes	Yes			Yes	Yes	Yes	Yes	
STEPPING				Yes							
SUSPEND	Yes	Yes	Yes	Yes					Yes		
SYSTEM_JITTER	Yes	Yes	Yes	Yes			Yes				
TEMPERATURE			Yes	Yes	Yes	Yes					
TIG	Yes		Yes	Yes	Yes	Yes	Yes	Yes			

Constraint	Schematic	VHDL Verilog	NCF	UCF	Constraints Editor	PCF	XCF	Plan-Ahead	PACE	FPGA Editor	ISE® Design Suite
TIMEGRP			Yes	Yes	Yes	Yes	Yes	Yes			
TIMESPEC			Yes	Yes	Yes		Yes	Yes			
TNM			Yes	Yes	Yes		Yes	Yes			
TNM_NET	Yes		Yes	Yes	Yes		Yes	Yes			
TPSYNC	Yes		Yes	Yes							
TPTHRU	Yes		Yes	Yes	Yes						
TSIdentifier			Yes	Yes	Yes	Yes	Yes			Yes	
U_SET	Yes	Yes	Yes	Yes			Yes				
USE_RLOC	Yes	Yes	Yes	Yes			Yes	Yes			
VCCAUX			Yes	Yes							
VCCAUX_IO	Yes	Yes	Yes	Yes							
VOLTAGE			Yes	Yes	Yes	Yes					
VREF	Yes		Yes	Yes							
WIREAND	Yes	Yes	Yes	Yes							
XBLKNM	Yes	Yes	Yes	Yes			Yes				

Schematic Design

Follow these rules to add Xilinx® constraints as attributes within a symbol or schematic drawing:

- If a constraint applies to a net, add it as an attribute to the net.
- If a constraint applies to an instance, add it as an attribute to the instance.
- You cannot add global constraints such as PART and [PROHIBIT](#).
- You cannot add any timing specifications that would be attached to a [TIMESPEC](#) or [TIMEGRP](#).
- Enter attribute names and values in either all uppercase or all lowercase. Mixed uppercase and lowercase is not allowed.

For more information about creating, modifying, and displaying attributes, see the Schematic and Symbol Editors Help.

The syntax for any constraint that can be entered in a schematic is described in the section for that constraint. For an example of correct schematic syntax, see the Schematic Syntax Example in [BEL](#).

VHDL Attributes

In VHDL code, constraints can be specified with VHDL attributes. Before it can be used, a constraint must be declared with the following syntax:

```
attribute attribute_name : string;
```

Example

```
attribute RLOC : string;
```

An attribute can be declared in an entity or architecture.

- If the attribute is declared in the entity, it is visible both in the entity and the architecture body.
- If the attribute is declared in the architecture, it cannot be used in the entity declaration.

Once the attribute is declared, you can specify a VHDL attribute as follows:

```
attribute attribute_name of {component_name | label_name | entity_name | signal_name | variable_name | type_name } :
{component | label | entity | signal | variable | type} is attribute_value ;
```

Accepted *attribute_values* depend on the attribute type.

Example One

```
attribute RLOC : string;
```

```
attribute RLOC of u123 : label is "R11C1.S0";
```

Example Two

```
attribute bufg: string;
```

```
attribute bufg of my_clock: signal is "clk";
```

For Xilinx® the most common objects are **signal**, **entity**, and **label**. A label describes an instance of a component.

Note The signal attribute must be used on the output port.

VHDL is case insensitive.

In some cases, existing Xilinx constraints cannot be used in attributes, since they are also VHDL keywords. To avoid this naming conflict, use a constraint alias. Each Xilinx constraint has its own alias. The alias is the original constraint name pre-pended with the prefix **XIL_**. For example, the **RANGE** constraint cannot be used in an attribute directly. Use **XIL_RANGE** instead.

Verilog Attributes

Verilog attributes are bounded by asterisks (*), and use the following syntax:

```
(* attribute_name = attribute_value *)
```

where

- *attribute* precedes the signal, module, or instance declaration to which it refers.
- *attribute_value* is a string. No integer or scalar values are allowed.
- *attribute_value* is between quotes.
- The default is 1. (* **attribute_name** *) is the same as (* **attribute_name** = "1" *).

Verilog Attributes Syntax Example One

```
(* clock_buffer = "IBUFG" *) input CLK;
```

Verilog Attributes Syntax Example Two

```
(* INIT = "0000" *) reg [3:0] d_out;
```

Verilog Attributes Syntax Example Three

```
always@(current_state or reset)
begin (* parallel_case *) (* full_case *)
case (current_state)
```

Verilog Attributes Syntax Example Four

```
(* mult_style = "pipe_lut" *) MULT my_mult (a, b, c);
```

Verilog Limitations

Verilog attributes are not supported for:

- Signal declarations
- Statements
- Port connections
- Expression operators

Verilog Meta Comments

Constraints can also be specified in Verilog code using meta comments. The Verilog format is the preferred syntax, but the meta comment style is still supported. Use the following syntax:

```
// synthesis attribute AttributeName [of] ObjectName [is] AttributeValue
```

Verilog Meta Comments Examples

```
// synthesis attribute RLOC of u123 is R11C1.S0  
// synthesis attribute HU_SET u1 MY_SET  
// synthesis attribute bufg of my_clock is "clk"
```

User Constraints File (UCF)

A User Constraints File (UCF) file is an ASCII file which specifies constraints on the logical design. You can create UCF files and enter constraints with:

- Any text editor
- [Constraints Editor](#)

These constraints affect how the logical design is implemented in the target device. You can use UCF files to override constraints specified during design entry.

UCF Flow

The following figure illustrates the UCF flow.

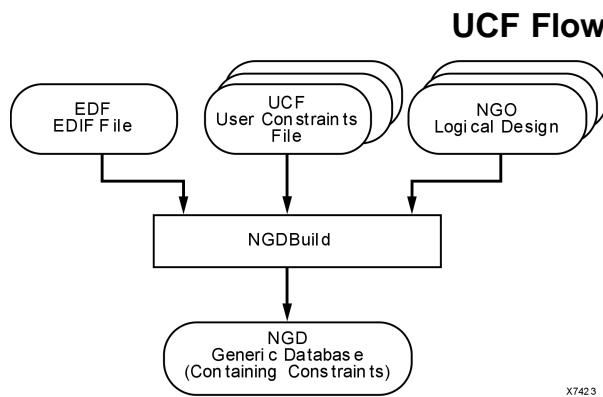

UCF files are input to NGDBuild (see the preceding figure). The constraints in the UCF files become part of the information in the NGD file produced by NGDBuild. For FPGA devices, some of these constraints are used when the design is mapped by MAP, and some of the constraints are written into the Physical Constraints File (PCF) produced by MAP.

The constraints in the PCF file are used by each of the physical design tools (for example, PAR and the timing analysis tools), which are run after the design is mapped.

Manual Entry of Timing Constraints

In addition to entering timing constraints through Constraints Editor, you can manually enter timing specifications as constraints in UCF files. When you run NGDBuild on the design, the timing constraints are added to the design database as part of the NGD file. You can also use the Constraints Editor to enter timing constraints in UCF files.

Constraint Conflicts in Multiple UCF Files

The Xilinx® software still uses "last constraint wins" just as in HDL, NCF, UCF, and PCF processing. Currently, the UCF files are processed in the order in which they are added to the project (either in the ISE® Design Suite or by means of Tcl commands), and it has no bearing on timestamps or the order in which the files were modified.

UCF and NCF File Syntax

Logical constraints are found in:

- The Netlist Constraints File (NCF), an ASCII file typically generated by synthesis programs
- The User Constraints File (UCF), an ASCII file generated by the user

Xilinx® recommends that you place user-generated constraints in the UCF or NCF files and not in the Physical Constraints File (PCF) file.

General Rules for UCF and NCF

- UCF and NCF files are case sensitive. Identifier names (names of objects, such as net names) must exactly match the case of the name as it exists in the source design netlist. However, any Xilinx constraint keyword (for example, LOC, PERIOD, HIGH, LOW) may be entered in all uppercase, all lowercase, or mixed case.
- Each statement is terminated by a semicolon (;).
- No continuation characters are necessary if a statement exceeds one line, since a semicolon marks the end of the statement.
- Xilinx recommends that you group similar blocks, or components, as a single timing constraint, and not as separate timing constraints.
- To add comments to the UCF and NCF files, begin each comment line with a pound (#) sign, as in the following example.

```
# file TEST.UCF
# net constraints for TEST design
NET "$SIG_0 MAXDELAY" = 10;
NET "$SIG_1 MAXDELAY" = 12 ns;
```

- Statements need not be placed in any particular order in the UCF and NCF file.
- Enclose NET and INST names in double quotes (recommended but not mandatory).
- Enclose inverted signal names that contain a tilde (for example, ~OUTSIG1) in double quotes (mandatory).
- You can enter multiple constraints for a given instance. For more information, see Entering Multiple Constraints below.

Conflict in Constraints

The constraints in the UCF and NCF files and the constraints in the schematic or synthesis file are applied equally. It does not matter whether a constraint is entered in the schematic, HDL, UCF or NCF files. If the constraints overlap, UCF overrides NCF and schematic/netlist constraints. NCF overrides schematic/netlist constraints.

If by mistake two or more elements are locked onto a single location, MAP detects the conflict, issues an error message, and stops processing so that you can correct the mistake.

Syntax

The UCF file supports a basic syntax that can be expressed as:

```
{NET|INST|PIN} "full_name" constraint;
```

- *full_name* is a full hierarchically qualified name of the object being referred to. When the name refers to a pin, the instance name of the element is also required.
- *constraint* is a constraint in the same form as it would be used if it were attached as an attribute on a schematic object. For example, LOC=P38 and FAST.

Specifying Attributes for TIMEGRP and TIMESPEC

To specify attributes for TIMEGRP, the keyword TIMEGRP precedes the attribute definitions in the constraints files.

```
TIMEGRP "input_pads"=PADS EXCEPT output_pads;
```

Using Reserved Words

In all of the constraints files (NCF, UCF, and PCF), instance or variable names that match internal reserved words may be rejected unless the names are enclosed in double quotes. It is good practice to enclose all names in double quotes.

For example, the following entry is not accepted because the word *net* is a reserved word.

```
NET net OFFSET=IN 20 BEFORE CLOCK;
```

Following is the recommended way to enter the constraint.

```
NET "net" OFFSET=IN 20 BEFORE CLOCK;
```

or

```
NET "$SIG_0" OFFSET=IN 20 BEFORE CLOCK;
```

Enclose inverted signal names that contain a tilde (for example, ~OUTSIG1) in double quotes (mandatory) as follows:

```
NET "~OUTSIG1" OFFSET=IN 20 BEFORE CLOCK;
```

Wildcards

You can use the wildcard characters, asterisk (*) and question mark (?) in constraint statements as follows:

- The asterisk (*) represents any string of zero or more characters.
- The question mark (?) indicates a single character.

In net names, the wildcard characters enable you to select a group of symbols whose output net names match a specific string or pattern. For example, the constraint shown below increases the output speed of pads to which nets are connected with names that meet the following patterns:

- They begin with any series of characters (represented by an asterisk [*]).
- The initial characters are followed by "AT."
- The net names end with one single character (represented by a question mark [?]).

```
NET "*AT?" FAST;
```

In an instance name, a wildcard character by itself represents every symbol of the appropriate type. For example, the following constraint initializes an entire set of ROMs to a particular hexadecimal value, 5555.

```
INST "$I13*/ROM2" INIT=5555;
```

If the wildcard character is used as part of a longer instance name, the wildcard represents one or more characters at that position.

In a location, you can use a wildcard character for either the row number or the column number. For example, the following constraint specifies placement of any instance under the hierarchy of loads_of_logic in any SLICE in column 8.

```
INST "/loads_of_logic/*" LOC=SLICE_X*Y8;
```

Wildcard characters cannot be used for both the row number and the column number in a single constraint, since such a constraint is meaningless.

Traversing Hierarchies

Top-level block names (design names) are ignored when searching for instance name matches. You can use the asterisk wildcard character (*) to traverse the hierarchy of a design within a UCF and NCF file. The following syntax applies (where level1 is an example hierarchy level name).

UCF Design Hierarchy

*	Traverses all levels of the hierarchy
level1/*	Traverses all blocks in level1 and below
level1/*/	Traverses all blocks in the level1 hierarchy level but no further

Consider the following design hierarchy.

UCF Design Hierarchy

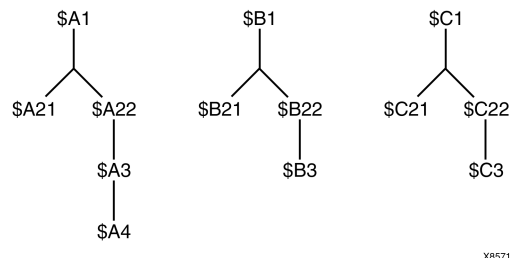

With the example design hierarchy, the following specifications illustrate the scope of the wildcard.

```

INST *           => <everything>
INST /*         => <everything>
INST /*/       => <$A1, $B1, $C1>
INST $A1/*     => <$A21, $A22, $A3, $A4>
INST $A1/*/    => <$A21, $A22>
INST $A1/*/*   => <$A3, $A4>
INST $A1/*/*/* => <$A3>
INST $A1/*/*/* => <$A4>
INST $A1/*/*/* => <$A4>
INST /*/*22/   => <$A22, $B22, $C22>
INST /*/*22    => <$A22, $A3, $A4, $B22, $B3, $C3>
  
```

Entering Multiple Constraints

You can cascade multiple constraints for a given instance in the UCF file:

```
INST instanceName constraintName = constraintValue | constraintName = constraintValue;
```

For example:

```
INST myInst LOC = P53 | IOSTANDARD = LVPECL33 | SLEW = FAST;
```

File Name

By default, NGDBuild reads the constraints file that carries the same name as the input design with a .ucf extension. However, you can specify a different constraints file name with the **-uc** option when running NGDBuild. NGDBuild automatically reads in the NCF file if it has the same base name as the input EDIF file and is in the same directory as the EDIF file.

The implementation tools (for example, NGDBuild, MAP, and PAR) require file name extensions in all lowercase (for example, .ucf) in command lines.

Instances and Blocks

The statements in the constraints file concern instances and blocks, which are defined as follows.

- An *instance* is a symbol on the schematic.
- An *instance name* is the symbol name as it appears in the EDIF netlist.
- A *block* is a CLB or an IOB.
- Specify the *block name* with the BLKNM, HBLKNM, or XBLKNM attributes. By default, the software assigns a block name on the basis of a signal name associated with the block.

Physical Constraints File (PCF)

The Native Generic Database (NGD) file produced when a design netlist is read into the Xilinx® ISE® Design Suite may contain a number of logical constraints. These constraints originate in any of these sources.

- An attribute assigned within a schematic or Hardware Description Language (HDL) file
- A constraint entered in a User Constraints File (UCF)
- A constraint appearing in an Netlist Constraints File (NCF) produced by a CAE vendor toolset

Logical constraints in the NGD file are read by MAP. MAP uses some of the constraints to map the design and converts logical constraints to physical constraints. MAP then writes these physical constraints into a Physical Constraints File (PCF).

The PCF file is an ASCII file containing two separate sections:

- A section for those physical constraints created by the mapper
- A section for physical constraints entered by the user

The mapper section is rewritten every time you run the mapper.

Mapper-generated physical constraints appear first in the file, followed by user physical constraints. In the event of conflicts between mapper-generated and user constraints, user constraints are read last, and override mapper-generated constraints.

The beginning of the mapper-generated section is indicated by **SCHEMATIC START**. The end of this section is indicated by **SCHEMATIC END**. Enter user-generated constraints, such as timing constraints, after **SCHEMATIC END**.

You can write user constraints directly into the file, or you can write them indirectly (or undo them) from within the FPGA Editor. For more information on constraints in the FPGA Editor, see the FPGA Editor help.

Note Whenever possible, you should add design constraints to the HDL, schematic, or UCF, instead of PCF. This simplifies design archiving and improves design role checking.

The PCF file is an optional input to PAR, FPGA Editor, TRACE, NetGen, and BitGen. The file may contain any number of constraints, and any number of comments, in any order. A comment consists of either a pound sign (#) or double slashes (//) followed by any number of other characters up to a new line. Each comment line must begin with a pound sign (#) or double slashes (//).

The structure of the PCF file is as follows.

schematic start;

translated schematic and UCF and NCF constraints in PCF format

schematic end;

user-entered physical constraints

Caution! Put all user-entered physical constraints after the schematic end statement. Any constraints preceding this section or within this section may be overwritten or ignored.

Do not edit the schematic constraints. They are overwritten every time the mapper generates a new PCF file.

Global constraints need not be attached to any object, but should be entered in a constraints file.

Indicate the end of each constraint statement with a semicolon.

In all of the constraints files (NCF, UCF, and PCF), instance or variable names that match internal reserved words are rejected unless the names are enclosed in double quotes. It is good practice to enclose all names in double quotes. For example, the following entry would not be accepted because the word *net* is a reserved word.

```
NET net FAST;
```

Following is the recommended way to enter the constraint.

```
NET "net" FAST;
```

Netlist Constraints File (NCF)

The syntax rules for the Netlist Constraints File (NCF) are the same as those for the User Constraints File (UCF). For more information, see [User Constraints File \(UCF\) and Netlist Constraints File \(NCF\) File Syntax](#).

Constraints Editor

The Constraints Editor is a graphical tool that simplifies the process of entering timing constraints. This tool guides you through the process of creating constraints without requiring you to understand User Constraints File (UCF) syntax. For the constraints and devices with which Constraints Editor can be used, see [Constraints Entry Methods](#). For information on running Constraints Editor, see the ISE® Design Suite Help

Constraints Editor is used in the implementation phase after the translation step (NGCBuild). Constraints Editor allows you to create and manipulate constraints without any direct editing of the UCF. After the constraints are created or modified with Constraints Editor, NGCBuild must be run again, using the new UCF and design source netlist files as input and generating a new NGD file as output.

Input/Output

Constraints Editor requires:

- A User Constraints File (UCF)
- A Native Generic Database (NGD) file

Constraints Editor uses the NGD file to provide names of logical elements for grouping. As output, it uses the UCF file.

After you open Constraints Editor, you must first open a UCF file. If the UCF and NGD root names are not the same, you must select the appropriate NGD file to open. For more information, see the Constraints Editor Help.

Upon successful completion, Constraints Editor writes out a UCF file. NGCBuild (translation) uses the UCF file, along with design source netlists, to produce an NGD file. The NGD file is read by the MAP program. MAP generates a physical design database in the form of a Native Circuit Description (NCD) file and also generates a Physical Constraints File (PCF). The implementation software uses these files to ultimately produce a bitstream.

Note Not all Xilinx® constraints are accessible through Constraints Editor.

Starting Constraints Editor

Constraints Editor runs on personal computers and workstations. You can start Constraints Editor:

- From ISE Design Suite
- As a Standalone Tool
- From the Command Line

Running Constraints Editor From ISE Design Suite

Within ISE Design Suite, launch Constraints Editor from the Processes window.

1. Select a design file in the Sources window.
2. Double-click **Processes > Design Utilities > User Constraints > Create Timing Constraints**.

Running Constraints Editor As a Standalone Tool

If you installed Constraints Editor as a standalone tool, either:

- Click the Constraints Editor icon on the Windows desktop, or
- Select **Start > Programs > Xilinx ISE > Accessories > Constraints Editor**

Running Constraints Editor From the Command Line With No Data Loaded

To start Constraints Editor from the command line with no data loaded, type:

```
constraints_editor
```

Running Constraints Editor From the Command Line With the NGD File Loaded

To start Constraints Editor from the command line with the NGD file loaded, enter:

```
constraints_editor ngdfile_name
```

ngdfile_name is the name of the NGD file

It is necessary to use the `.ngd` extension.

If a UCF file with the same base name as the NGD file exists, it is loaded also. Otherwise, you are prompted for a UCF file.

Running Constraints Editor From the Command Line With the NGD File and the UCF File Loaded

To start Constraints Editor from the command line with the NGD file and the UCF file loaded, enter:

```
constraints_editor ngdfile_name -uc ucf_file_name
```

- *ngdfile_name* is the name of the NGD file
- *ucf_file_name* is the name of the UCF file

It is necessary to use the `.ucf` extension.

Running Constraints Editor From the Command Line As a Background Process

To run Constraints Editor as a background process on a workstation, enter:

```
constraints_editor &
```

ISE Design Suite

To set implementation constraints in ISE® Design Suite:

- For FPGA devices, the implementation process properties specify how a design is translated, mapped, placed, and routed. You can set multiple properties to control the implementation processes.
- For CPLD devices, the implementation process properties specify how a design is translated and fit.

For more information, see the ISE Design Suite help for the Process Properties dialog box.

PlanAhead

You can use the PlanAhead™ software either before or after synthesis. The PlanAhead software supports the following devices:

- Virtex®-4 devices and higher
- Spartan®-3 devices and higher

The PlanAhead software allows you to drag-and-drop placement constraints, including:

- Pinout
- Logic placement
- Area

For more information, see the *PlanAhead User Guide (UG632)*.

Assigning Placement Constraints

For FPGA devices, you can use the PlanAhead software to enter placement constraints that control:

- I/O pin and logic assignments
- Global logic placement
- Area group assignment

The PlanAhead software runs automatically at various stages of the design process to allow you to analyze the design and to apply placement constraints. A simplified version of the PlanAhead software is invoked from ISE® Design Suite to enable only the types of features required to perform the selected tasks. The standalone PlanAhead software has many more features available.

When the PlanAhead software is invoked from ISE Design Suite, it is a separate CPU process and does not communicate realtime with ISE Design Suite as some other tools do. In order to prevent data mismatch or out of sync issues, do not update ISE Design Suite source files while the PlanAhead software is running .

When the PlanAhead software is invoked, the appropriate source files are passed to the PlanAhead software to populate the PlanAhead Project. When the PlanAhead Project is saved, only the modified UCF files are passed back to ISE Design Suite to update the Project. These input source files vary depending on the process step invoked.

For more information on the types of files passed, see the *Pin Assignment* and *Floorplanning and Placement Constraints* sections later in this chapter. The following sections cover strategies for entering placement constraints using the PlanAhead software.

Defining I/O Pin Configurations

This section discusses Defining I/O Pin Configurations and includes:

- Pin Assignment Overview
- Reviewing I/O Pin Data Information
- Pin Assignment
- I/O Planner Documentation

Pin Assignment Overview

I/O Planner can be invoked either as a standalone tool or from within ISE Design Suite. Invoking I/O Planner standalone can be helpful early in the design process when HDL sources may not yet be complete. I/O ports can be defined manually within the tool, or by importing a CSV format spreadsheet or HDL sources. You can define an initial pinout and export a User Constraints File (UCF) file for use in the ISE Design Suite flow.

A UCF file is required when invoking I/O Planner from within ISE Design Suite. If a UCF file does not exist, an empty one is created. Creation of I/O ports manually or by importing a CSV spreadsheet is not enabled when invoking I/O Planner from ISE Design Suite.

I/O Planner is an I/O pin assignment environment containing many helpful views and capabilities. You can selectively drag and drop groups of I/O ports onto the device using a variety of methods. An automatic placement routine is also available. Comprehensive Design Rule Checks (DRCs) ensure legal pinout definition.

Reviewing I/O Pin Data Information

[Data Sheets](#) provide device specifications, including I/O standards. To get device-specific I/O standard information, see the data sheet for the device you are targeting. A lot of the data contained in the data sheets is also available inside of the I/O Planner tool. The types of information available include I/O standards, clock capable pins, internal trace delays, differential pairs, clock region and I/O bank contents, etc. Information about I/O related device resources such as global and regional clock buffers, I/O delays and delay controllers, gigabit transceivers, etc. is also available.

Pin Assignment

To invoke I/O Planner standalone either click the PlanAhead Windows Desktop icon or enter PlanAhead on the Linux command line. From ISE Design Suite, you can use any of the following methods to start your pin assignment process, which allows you to choose the method most convenient for you:

- Floorplanning I/O – Pre-Synthesis

When using this command or process step, the HDL source files are passed to the PlanAhead software in order to extract the top level I/O port information only. If a UCF files exists in the ISE Design Suite project, it is passed to the PlanAhead software for modification. If a UCF does not exist, you are prompted to create one. If multiple UCF files exist, you are prompted to select the desired file to add new constraints to. Existing constraints are modified in whichever file they are contained in.

Refer to the I/O Planner Documentation section for information on using the I/O Planner environment contained in the PlanAhead software.

Once the I/O pin assignment is made, you save the PlanAhead software project and exit the PlanAhead software. This updates the UCF files in the ISE Design Suite project and update the project status accordingly. Exiting the PlanAhead software without saving does not change the ISE Design Suite UCF source files or status.

- Floorplanning a Design – Post-Synthesis

When using this command or process step, the synthesized netlist source files are passed to the PlanAhead software. If a UCF files exists in the ISE Design Suite project, it is passed to the PlanAhead software for modification. If a UCF does not exist, you are prompted to create one. If multiple UCF files exist, you are prompted to select the desired file to add new constraints to. Existing constraints are modified in whichever file they are contained in.

Having a synthesized netlist as input enables more functionality in I/O Planner since the tool is now aware of the clocks and clock related logic in the design. Additional I/O planning capabilities and DRCs are provided to make more intelligent pin assignment decisions. The design connectivity can also be analyzed to ensure optimized use of device resources in relation to the I/Os.

Refer to the I/O Planner Documentation section for information on using the I/O Planner environment contained in the PlanAhead software.

Once the I/O pin assignment is made, you will then save the PlanAhead software project and exit the PlanAhead software. This will update the UCF files in the Project Navigator project and update the project status accordingly. Exiting PlanAhead without saving with not change the ISE Design Suite UCF source files or status.

I/O Planning Documentation

The *PlanAhead User Guide (UG632)* contains a section on I/O planning for analyzing the device resources and I/O pin assignment.

The *PlanAhead Software Tutorial: I/O Pin Planning (UG674)*, and the *Pin Planning Methodology Guide (UG792)* are also available.

Floorplanning and Placement Constraints

The PlanAhead software provides a comprehensive environment for analyzing the design from a number of different aspects including connectivity, density, and timing. You can then apply placement constraints to help drive the implementation tools toward better or more consistent results. These constraints may include LOC constraints to lock specific logic objects into specific sites on the device or AREA_GROUP constraints to constrain a group of logic within a specific area of the device.

Placement LOC Constraint Assignment

The PlanAhead software enables you to lock down any logic to specific device sites. This often includes global logic objects such as the following: BUFG, BRAM, MULT, PPC405, GT, DLL, and DCM.

You can place logic objects by simply dragging the desired logic object from any of the appropriate PlanAhead software views and drop it in the Device View in the Workspace. Some types of logic such as I/O ports enable you to enter the desired location site in the object General Properties view.

For more information about assigning placement constraints, see “Using Placement Constraints” in the “Floorplanning the Design” chapter of the *PlanAhead User Guide* (UG632).

Area Group Assignment

Area groups are the primary means of placing logic in specific regions of the device, for example, within a particular clock region. The PlanAhead software enables you to create area groups using a wide variety of methods. Assistance with connectivity, size logic types and ranges are all provided by the tool including DRCs to ensure proper [Area Group \(AREA_GROUP\)](#) property definition.

For more information about creating area group constraints, see *Floorplanning the Design* in the *PlanAhead User Guide* (UG632).

Setting Constraints in PACE

For CPLD devices, you can set constraints in the Pinout and Area Constraints Editor (PACE). The Pin Assignments Editor in PACE is used to:

- Assign location constraints to IOs.
- Assign IO properties such as IO Standards.

For a list of the constraints and devices with which PACE can be used, see [Constraints Entry Methods](#). For more information about accessing and using PACE, see the ISE® Design Suite Help.

Partial Design Pin Preassignment

This section deals with Pin Preassignment when a design is partially completed. For information on Pin Preassignment in which a Hardware Description Language (HDL) template is built by adding constraints to pins that are defined within PlanAhead™ or PACE, see the ISE® Design Suite Help. PACE is supported for CPLD devices. PlanAhead is supported for FPGA devices.

Designs that are not yet fully coded might still have layout requirements. Pin assignments, voltage standards, banking rules, and other board requirements might be in place long before the design has reached the point where these constraints can be applied. Pin Preassignment allows the design pinout rules to be determined before the design logic has been completed.

To use Pin Preassignment in PlanAhead or PACE:

1. Provide the complete list of ports in your top-level design
2. Assign I/O constraints to them

Even if the ports are not used by any logic (that is, no loads for input pins, no sources for output pins), they can still receive constraints and be kept through implementation.

Assign [Location \(LOC\)](#) or [Input Output Standard \(IOSTANDARD\)](#) constraints in the User Constraints File (UCF) just like for any I/O pin. These requirements are annotated in the database. PlanAhead and PACE can be used to assign pin locations, banking groups or voltage standards, and DRC checks can be run. The final PAD report contains any pins that have logic or constraints associated with them.

This implementation is incomplete and cannot be downloaded to the hardware. You should expect these errors during the DRC phase of bitstream generation (BitGen):

- ERROR: PhysDesignRules:368 - The signal <D_OBUF> is incomplete. The signal is not driven by any source pin in the design.
- ERROR: PhysDesignRules:10 - The network <D_OBUF> is completely unrouted.

To trim any unused ports from the design, remove the associated constraints. The Translate (NGDBuild) phase trims these unused pins.

In this example, there are six top-level ports. Only three (clk, A, C) are currently used. Of the remaining three ports:

- B is kept because it has a [Location \(LOC\)](#) constraint.
- D is kept because it has an [Input Output Standard \(IOSTANDARD\)](#) constraint.
- E is trimmed because it is completely unused and unconstrained.

Verilog Example

```
-----  
module design_top(clk, A, B, C, D, E);  
input clk, A, B;  
output reg C, D, E;  
  
always@(posedge clk)  
C <= A;  
  
endmodule
```

UCF Example

```
-----  
  
NET "A" LOC = "E2" ;  
NET "B" LOC = "E3" ;  
NET "C" LOC = "B15" ;  
NET "D" IOSTANDARD = SSTL2_II ;
```

FPGA Editor

You can add or delete certain constraints in the Physical Constraints File (PCF) using FPGA Editor. FPGA Editor supports net, site, and component constraints as property fields in the individual nets and components. Properties are set with the **Setattr** command, and are read with the **Getattr** command.

All Boolean constraints, including **BLOCK**, **Locate (LOCATE)**, **LOCK**, **Offset In (OFFSET IN)**, **Offset Out (OFFSET OUT)**, and **Prohibit (PROHIBIT)**, have values of **On** or **Off**. Offset direction has a value of either **In** or **Out**. Offset order has a value of either **Before** or **After**. All other constraints have a numeric value. They can also be set to **Off** in order to delete the constraint. All values are case-insensitive (for example, **On** and **on** are both accepted).

When you create a constraint in the FPGA Editor, the constraint is written to the PCF file whenever you save your design. When you use the FPGA Editor to delete a constraint, and then save your design file, the line on which the constraint appears in the PCF file remains in the file but is automatically commented out. Some of the constraints supported in the FPGA Editor are listed in the following table.

Constraints Supported in FPGA Editor

Constraint	Accessed Through
block paths	Component Properties and Path Properties property sheet
define path	Viewed with Path Properties property sheet
location range	Component Properties Constraints page
locate macro	Macro Properties Constraints page
lock placement	Component Properties Constraints page
lock routing of this net	Net Properties Constraints page
lock routing	Net Properties Constraints page
maxdelay allnets	Main Properties Constraints page
maxdelay allpaths	Main Properties Constraints page
maxdelay net	Net Properties Constraints page
maxdelay path	Path Properties property sheet
maxskew	Main Properties Constraints page
maxskew net	Net Properties Constraints page
offset comp	Component Properties Offset page
penalize tilde	Main Properties Constraints page
period	Main Properties Constraints page
period net	Net Properties Constraints page
prioritize net	Net Properties Constraints page
prohibit site	Site Properties property sheet

Locked Nets and Components

If a net is locked, you cannot unrout any portion of the net, including the entire net, a net segment, a pin, or a wire. To unrout the net, you must first unlock it. You can add pins or routing to a locked net.

A net is displayed as locked in the FPGA Editor if the Lock Net [*net_name*] constraint is enabled in the PCF file. You can use the Net Properties property sheet to remove the lock constraint.

When a component is locked, one of the following constraints is set in the PCF file.

lock comp [*comp_name*]

locate comp [*comp_name*]

lock macro [*macro_name*]

lock placement

If a component is locked, you cannot unplace it, but you can unrout it. To unplace the component, you must first unlock it.

Interaction Between Constraints

Schematic constraints are placed at the beginning of the PCF file by MAP. The start of this section is indicated with **SCHEMATIC START**. The end of this section is indicated with **SCHEMATIC END**. Because of a last-read order, all constraints that you enter in this file should come after **SCHEMATIC END**.

You are not prohibited from entering a user constraint before the schematic constraints section, but if you do, a conflicting constraint in the schematic-based section may override your entry.

Every time a design is remapped, the schematic section of the PCF file is overwritten by the mapper. The user constraints section is left intact, but certain constraints may be invalid because of the new mapping.

XST Constraint File (XCF)

XST constraints can be specified in the XST Constraint File (XCF). The XCF has an extension of `.xcf`. For more information, see:

- ISE® Design Suite Help
- XST Constraint File (XCF) section in the *XST User Guide for Virtex-4, Virtex-5, Spartan-3, and Newer CPLD Devices*

Constraint Priority

In some cases more than one timing constraint covers the same path. The constraint conflict must be resolved, with the higher priority constraint taking precedence and being applied to the path, and the lower priority constraints being ignored for that path. The method of constraints resolution depends on both the order of constraint specification as well as the priority of the constraints specified. The rules of constraint priority resolution are described below. This determination is based upon the constraint prioritization or which constraint appears later in the Physical Constraints File (PCF), if there are overlapping constraints of the same priority. For example, if the design has two **Period (PERIOD)** constraints that cover the same paths, the later **Period (PERIOD)** constraint in the PCF file covers or analyzes these paths. The previous **Period (PERIOD)** constraints have “0 items analyzed” in the timing report. In order to modify the default constraint resolution behavior, the constraint priority can be assigned using the **PRIORITY** keyword.

File Priorities

When conflicting constraints have the same priority, the order of specification is used to determine the constraint that takes precedence. The resolution rule for identical priority constraints is the constraint that is specified last overwrites any previously defined constraints. This rule applies to constraints within a single User Constraints File (UCF) as well as constraints defined in multiple UCF files.

The following list defines the precedence order of identical priority constraints when these constraints are defined in different constraint files. The list is given in descending priority order with the highest priority constraint listed first.

- Constraints in a Physical Constraints File (PCF)
- Constraints in a User Constraints File (UCF)
- Constraints in a Netlist Constraints File (NCF)
- Attributes in a schematic or Constraints specified in HDL that are passed down in the netlist

Timing Specification Priorities

When two different constraints cover the same path, the constraint with the highest priority takes precedence and is applied to that path. Other constraints are ignored. Constraint priority is as follows, in descending order from highest to lowest.

- [Timing Ignore \(TIG\)](#)
- [From Thru To \(FROM-THRU-TO\)](#)
 - Source and Destination are User Defined Groups
 - Source or Destination are User Defined Groups
 - Source and Destination are Predefined Groups
- [From To \(FROM-TO\)](#)
 - Source and Destination are User Defined Groups
 - Source or Destination are User Defined Groups
 - Source and Destination are Predefined Groups
- [OFFSET IN \(Offset In\)](#) and [OFFSET OUT \(Offset Out\)](#)
 - Specific Data IOB (NET OFFSET) Constraint
 - Time Group of Data IOBs (Grouped OFFSET) Constraint
 - All Data IOBs (Global OFFSET) Constraint
- [Period \(PERIOD\)](#)

OFFSET Priorities

If two specific OFFSET constraints at the same level of precedence cover the same path, an OFFSET with a register qualifier takes precedence over an OFFSET without a qualifier; if otherwise equivalent, the latter in the constraint file takes precedence.

MAXSKEW and MAXDELAY Priorities

Net delay and net skew specifications are analyzed independently of path delay analysis and do not interfere with one another. NET TIG do interact with the NET constraints and take precedence.

Constraint Priority Exceptions

Use [Priority \(PRIORITY\)](#) to override the default constraint resolution behavior. [Priority \(PRIORITY\)](#) uses a value of -255 to $+255$ to manually assign a priority to a constraint. The smaller the constraint value, the higher the constraint priority. This keyword affects constraint resolution priority only, and does not influence the priority in which the implementation tools Place and Route the resources covered by the constraint. For more information, see [Priority \(PRIORITY\)](#).

Constraint Set Interaction

There are circumstances in which constraint priority may not operate as expected. These cases include supersets, subsets, and intersecting sets of constraints. See the following figure.

Interaction Between Constraint Sets

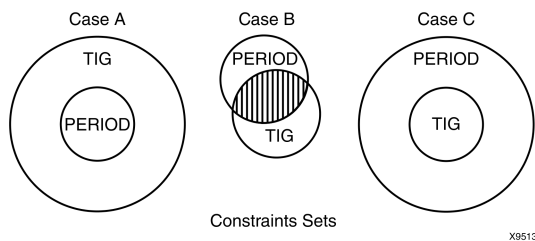

- In Case A, the **Timing Ignore (TIG)** superset conflicts with the **Period (PERIOD)** set.
- In Case B, the intersection of the **Period (PERIOD)** and TIG sets creates an ambiguous circumstance. In this instance, constraints may sometimes be considered as part of **Timing Ignore (TIG)**, and at other times part of **Period (PERIOD)**.

Timing Constraint Strategies

The goal of using timing constraints is to ensure that all the design requirements are communicated to the implementation tools. This goal also implies that all paths are covered by the appropriate constraint. This chapter provides general guidelines that explain the strategy for identifying and constraining the most common timing paths in FPGA devices in the most efficient manner possible.

Note For more information, see the *Timing Constraints User Guide (UG612)*.

Basic Constraints Methodology

In order to ensure a valid design, the timing requirements for all paths must be communicated to the implementation software. The timing requirements can be broken down into several global categories based on the type of path that is to be covered. The most common types of path categories include:

- Input paths
- Register-to-register paths
- Output paths
- Path specific exceptions

A Xilinx® timing constraint is associated with each of these global category types. The most efficient way to specify these constraints is to begin with global constraints, then add path specific exceptions as needed. In many cases, only the global constraints are required.

The FPGA implementation software is driven by the specified timing requirements. The software assigns device resources, and expends the appropriate amount of effort necessary to ensure that the timing requirements are met. However, when a requirement is over-constrained (or specified as a value greater than the design requirement), the effort to meet this constraint increases significantly, and results in increased memory use and tool runtime. In addition, over-constraining can degrade performance for not only that particular constraint, but for other constraints as well. For this reason, Xilinx recommends that you specify the constraint values using the actual design requirements.

The method of applying constraints given in this guide uses User Constraints File (UCF) constraint syntax examples. This format highlights the constraints syntax that conveys the design requirements. However, the easiest way to enter design constraints is to use Constraints Editor, which:

- Provides a unified location in which to manage all timing constraints associated with a design
- Provides assistance in creating timing constraints from the design requirements

Input Timing Constraints

This section discusses how to specify input timing constraints and includes:

- Input Timing Constraints Overview
- System Synchronous Input
- Timing Diagram for Ideal System Synchronous SDR Interface Example
- Source Synchronous Inputs
- Timing Diagram for Ideal Source Synchronous DDR Interface Example

Input Timing Constraints Overview

Input timing constraints cover the data path from the external pin of the FPGA device to the internal register that captures that data. Use [OFFSET IN](#) to specify the input timing. The best way to specify the input timing requirements depends on the type (source or system synchronous) and data rate (SDR or DDR) of the interface.

[OFFSET IN](#) defines the relationship between the data and the clock edge used to capture that data at the pins of the FPGA device. When analyzing [OFFSET IN](#), the timing analysis software automatically take all internal factors affecting the delay of the clock and data into account. These factors include:

- Frequency and phase transformations of the clock
- Clock uncertainties
- Data delay adjustments

In addition to the automatic adjustments, you may also add additional input clock uncertainty to the [PERIOD](#) constraint associated with the interface clock. For more information on the [PERIOD](#) constraint and adding `INPUT_JITTER`, see [PERIOD](#).

[OFFSET IN](#) is associated with a single input clock. By default, [OFFSET IN](#) covers all paths from the input pads of the FPGA device to the internal registers that capture that data and are triggered by the specified [OFFSET IN](#) clock. This application of [OFFSET IN](#) is called the global method, and is the most efficient way to specify input timing.

System Synchronous Inputs

The system synchronous interface is an interface in which a common system clock is used to both transfer and capture the data. The following figure shows a simplified System Synchronous interface with associated SDR timing.

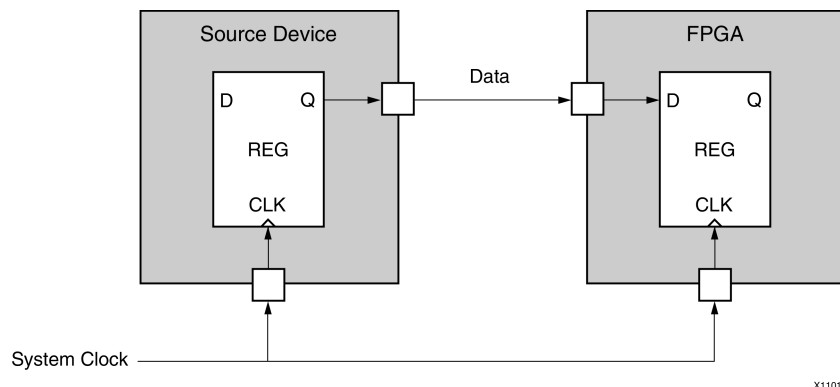

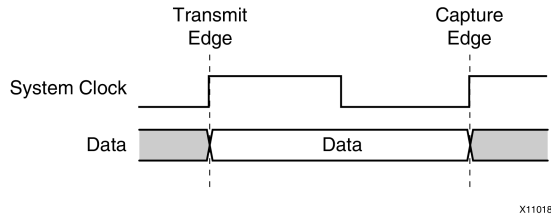

Because this interface uses a common system clock, board trace delays and skew limit the operating frequency of the interface. The lower frequency also results in the system synchronous input interface typically being a single data rate (SDR) application. In this system synchronous SDR application example, the data is transmitted from the source device on one rising clock edge and captured in the FPGA device on the next rising clock edge.

Using **OFFSET IN** is the most efficient way to specify the input timing for a system synchronous interface. In this method, one **PERIOD** constraint is defined for each system synchronous input interface clock. This single constraint covers the paths of all input data bits that are captured in registers triggered by the specified input clock.

To specify the input timing:

1. Specify the clock **OFFSET IN** constraint for the input clock associated with the interface.
2. Define the global **OFFSET IN** constraint for the interface.

Timing Diagram for Ideal System Synchronous SDR Interface Example

The following example shows a timing diagram for an ideal System Synchronous SDR interface. The interface has a clock period of 5 ns and the data for both bits of the bus remains valid for the entire period.

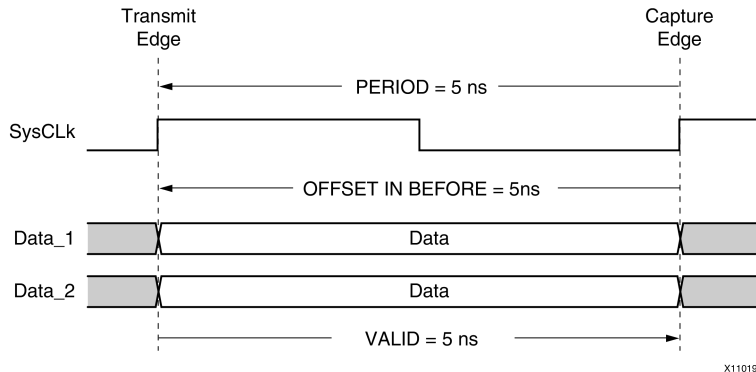

The global **OFFSET IN** constraint is defined as:

OFFSET = IN value VALID value BEFORE clock;

For **OFFSET IN**, *value* determines the time from the capturing clock edge in which data first becomes valid. In this system synchronous example, the data becomes valid 5 ns before the capturing clock edge. For **OFFSET IN**, the *VALID value* determines the duration in which data remains valid. In this example, the data remains valid for 5 ns. For this example, the complete **OFFSET IN** specification with an associated **PERIOD** is:

NET "SysClk" TNM_NET = "SysClk";

TIMESPEC "TS_SysClk" = PERIOD "SysClk" 5 ns HIGH 50%;

OFFSET = IN 5 ns VALID 5 ns BEFORE "SysClk";

This global constraint covers both data bits of the bus (data1, data2).

Source Synchronous Inputs

The source synchronous interface is an interface in which a clock is regenerated and transmitted along with the data from the source device. This clock is then used to capture the data in the FPGA device. A simplified Source Synchronous interface with associated DDR timing is shown in the following diagram.

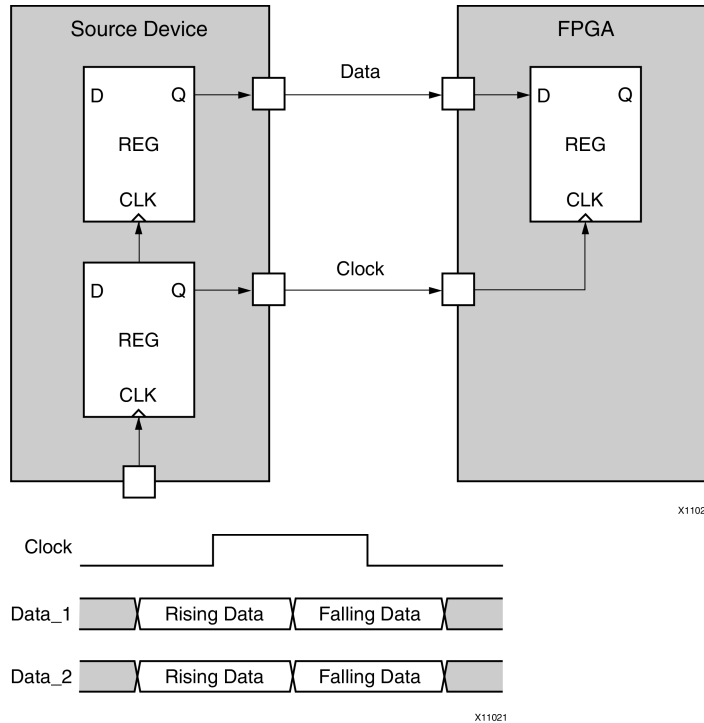

Because this interface uses a regenerated clock that is transmitted along the same board traces as the data, the board trace delays and skew no longer limit the operating frequency of the interface. The higher frequency also results in the source synchronous input interface typically being a dual data rate (DDR) application. In this source synchronous DDR application example, unique data is transmitted from the source device on both the rising and falling clock edges and captured in the FPGA using the regenerated clock.

Using **OFFSET IN** is the most efficient way to specify the input timing for a source synchronous interface. In the DDR interface, one **OFFSET IN** constraint is defined for each edge of the input interface clock. These constraints will cover the paths of all input data bits that are captured in registers triggered by the specified input clock edge.

To specify the input timing:

1. Specify the clock **PERIOD** constraint for the input clock associated with the interface.
2. Define the global **OFFSET IN** constraint for the rising edge of the interface.
3. Define the global **OFFSET IN** constraint for the falling edge of the interface.

Timing Diagram for Ideal Source Synchronous DDR Interface Example

The following example shows a timing diagram for an ideal Source Synchronous DDR interface. The interface has a clock period of 5 ns with a 50/50 duty cycle, and the data for both bits of the bus remains valid for the entire $\frac{1}{2}$ period.

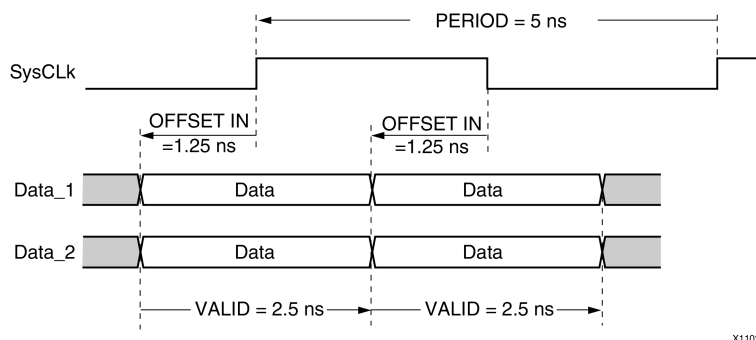

X11022

The global **OFFSET IN** constraint for the DDR case is defined as:

OFFSET = IN *value* **VALID** *value* **BEFORE** *clock* **RISING**;

OFFSET = IN *value* **VALID** *value* **BEFORE** *clock* **FALLING**;

For **OFFSET IN**, *value* determines the time from the capturing clock edge in which data first becomes valid. In this source synchronous example, the rising data becomes valid 1.25 ns before the capturing rising clock edge and the falling data also becomes valid 1.25 ns before the capturing falling clock edge. For **OFFSET IN**, the **VALID** *value* determines the duration in which data remains valid. In this example, both the rising and falling data remains valid for 2.5 ns. For this example, the complete **OFFSET IN** specification with an associated **PERIOD** is:

NET "SysCLK" **TNM_NET** = "SysClk";

TIMESPEC "TS_SysClk" = **PERIOD** "SysClk" 5 ns **HIGH** 50%;

OFFSET = IN 1.25 ns **VALID** 2.5 ns **BEFORE** "SysClk" **RISING**;

OFFSET = IN 1.25 ns **VALID** 2.5 ns **BEFORE** "SysClk" **FALLING**;

These global constraints cover both data bits of the bus (data1, data2).

Register-to-Register Timing Constraints

This section discusses the methodology for the specification of register-to-register synchronous path timing requirements. Register-to-register constraints cover the synchronous data paths between internal registers. This section includes:

- Register-to-Register Timing Constraints Overview
- Automatically Related DCM/PLL/MMCM Clocks
- Manually Related Clock Domains
- Asynchronous Clock Domains

Register-to-Register Timing Constraints Overview

PERIOD defines the timing of the clock domains. **PERIOD** not only analyzes the paths within a single clock domain, but analyzes all paths between related clock domains as well. In addition, **PERIOD** automatically takes into account all frequency, phase, and uncertainty differences between the domains during analysis.

The application and methodology for constraining synchronous clock domains falls under several common categories. These categories include:

- Automatically related DCM/PLL/MMCM Clock Domains
- Manually related Clock Domains
- Asynchronous Clock Domains

By allowing the tools to automatically create clock relationships for DCM/PLL/MMCM output clocks, and manually defining relationships for externally related clocks, all synchronous cross-clock-domain paths will be covered by the appropriate constraints, and properly analyzed. With proper application of **PERIOD** constraints that follows this methodology, the need for additional cross-clock-domain constraints is eliminated.

Automatically Related DCM/PLL/MMCM Clocks

The most common type of clock circuit is one in which the input clock is fed into a DCM/PLL/MMCM and the outputs are used to clock the synchronous paths in the device. In this scenario, the recommended methodology is to define a **PERIOD** constraint on the input clock to the DCM/PLL/MMCM. By placing **PERIOD** on the input clock, the Xilinx® software automatically derives a new **PERIOD** for each of the DCM/PLL/MMCM output clocks. In addition, the tools will automatically determine the clock relationships between the output clock domains, and automatically perform an analysis for any paths between these synchronous domains.

Example

In this example, the input clock goes to a DCM. The following figure shows the circuit for this example:

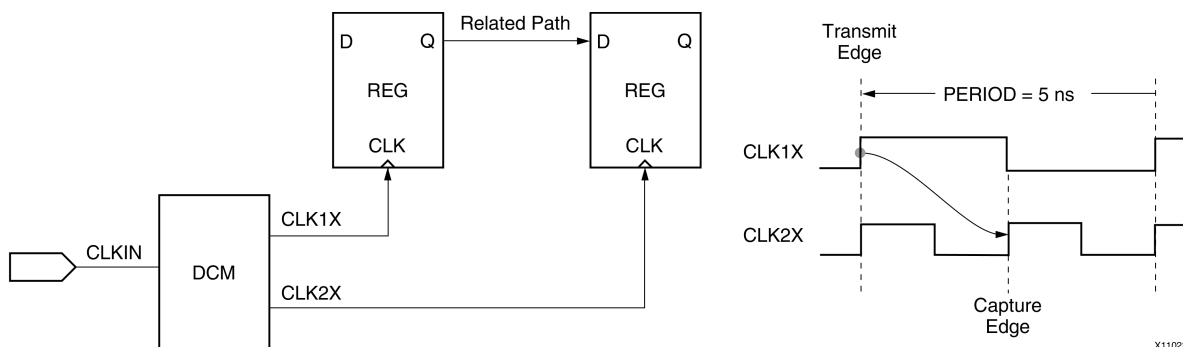

The **PERIOD** constraint syntax for this example is:

```
NET "ClockName" TNM_NET = "TNM_NET_Name";
TIMESPEC "TS_name" = PERIOD "TNM_NET_Name" PeriodValue HIGH HighValue%;
```

For **PERIOD**, the *PeriodValue* defines the duration of the clock period. In this case, the input clock to the DCM has a period of 5 ns. The *HighValue* of the **PERIOD** constraint defines the percent of the clock waveform that is **HIGH**. In this example, the waveform has a 50/50 duty cycle resulting in a *HighValue* of 50%. The syntax for this example is:

```
NET "ClkIn" TNM_NET = "ClkIn";
TIMESPEC "TS_ClkIn" = PERIOD "ClkIn" 5 ns HIGH 50%;
```

Based on the input clock **PERIOD** constraint given above, the DCM automatically creates two output clock constraints for the DCM outputs, and automatically performs analysis between the two domains.

Manually Related Clock Domains

In some cases, the relationship between synchronous clock domains cannot be automatically determined by the tools. One example occurs when related clocks enter the FPGA device on separate pins. In this scenario, the recommended constraint methodology is to create separate **PERIOD** constraints for both input clocks and define a manual relationship between the clocks. Once the manual relationship is defined, all paths between the two synchronous domains are automatically analyzed with all frequency, phase, and uncertainty information automatically taken into account.

The Xilinx constraints system allows for complex manual relationships to be defined between clock domains using **PERIOD**. This manual relationship can include clock frequency and phase transformations. The methodology for this process is:

1. Define **PERIOD** for the primary clock
2. Define the **PERIOD** constraint for the related clock using the first **PERIOD** constraint as a reference

Example

In this example two related clocks enter the FPGA device through separate external pins. The first clock, **CLK1X**, is the primary clock, and the second clock, **CLK2X180** is the related clock. The circuit for this example is shown in the following figure:

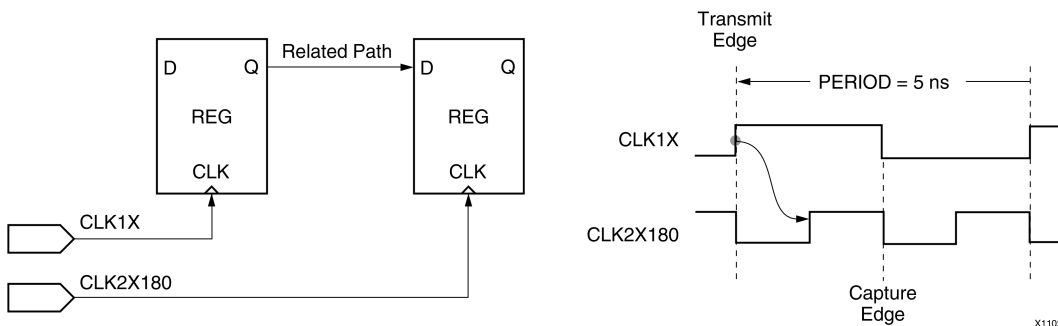

The **PERIOD** syntax for this example is:

```
NET "PrimaryClock" TNM_NET = "TNM_Primary";
NET "RelatedClock" TNM_NET = "TNM_Related";
TIMESPEC "TS_primary" = PERIOD "TNM_Primary" PeriodValue HIGH HighValue%;
TIMESPEC "TS_related" = PERIOD "TNM_Related" TS_Primary_relation PHASE value;
```

In the related [PERIOD](#) definition, the [PERIOD](#) value is defined as a time unit (period) relationship to the primary clock. The relationship is expressed in terms of the primary clock [TIMESPEC](#). In this example CLK2X180 operates at twice the frequency of CLK1X which results in a [PERIOD](#) relationship of $\frac{1}{2}$. In the related [PERIOD](#) definition, the [PHASE](#) value defines the difference in time between the rising clock edge of the source clock and the related clock. In this example, the CLK2X180 clock is 180 degrees shifted, so the rising edge begins 1.25 ns after the rising edge of the primary clock. The syntax for this example is:

```
NET "Clk1X" TNM_NET = "Clk1X";  
NET "Clk2X180" TNM_NET = "Clk2X180";  
TIMESPEC "TS_Clk1X" = PERIOD "Clk1X" 5 ns;  
TIMESPEC "TS_Clk2X180" = PERIOD "Clk2X180" TS_Clk1X/2 PHASE +  
1.25 ns ;
```

Asynchronous Clock Domains

Asynchronous clock domains are defined as those in which the transmit and capture clocks bear no frequency or phase relationship. Because the clocks are not related, it is not possible to determine the final relationship for setup and hold time analysis. For this reason, it is recommended that proper asynchronous design techniques be employed to ensure the successful capture of data. However, while not required, in some cases designers wish to constrain the maximum data path delay in isolation without regard to clock path frequency or phase relationship.

The Xilinx constraints system allows for the constraining of the maximum data path delay without regard to source and destination clock frequency and phase relationship.

This requirement is specified using [FROM-TO](#) with the **DATAPATHONLY** keyword.

The methodology for this process is:

1. Define a time group for the source registers
2. Define a time group for the destination registers
3. Define the maximum delay of the net using [FROM-TO](#) between the two time groups with **DATAPATHONLY** keyword.

For more information on using [FROM-TO](#) with the **DATAPATHONLY** keyword, see [FROM-TO](#).

Example

In this example two unrelated clocks enter the FPGA device through separate external pins. The first clock, **CLKA**, is the source clock, and the second clock, **CLKB** is the destination clock. The circuit for this example is shown in the following figure:

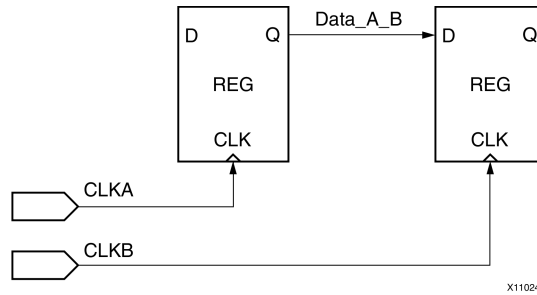

```
NET "CLKA" TNM_NET = FFS "GRP_A";  
NET "CLKB" TNM_NET = FFS "GRP_B";  
TIMESPEC TS_Example = FROM "GRP_A" TO "GRP_B" 5 ns DATAPATHONLY;
```

Output Timing Constraints

This section discusses how to specify output timing constraints. Output timing constraints cover the data path from a register inside the FPGA device to the external pin of the FPGA device.

Output Timing Constraints Overview

Use **OFFSET OUT** to specify output timing. The best way to specify the output timing requirements depends on the type (source/system synchronous) and data rate (SDR/DDR) of the interface.

OFFSET OUT defines the maximum time allowed for data to be transmitted from the FPGA device. The output delay path begins at the input clock pin of the FPGA device and continues through the output register to the data pins of the FPGA. This path is shown in the following diagram.

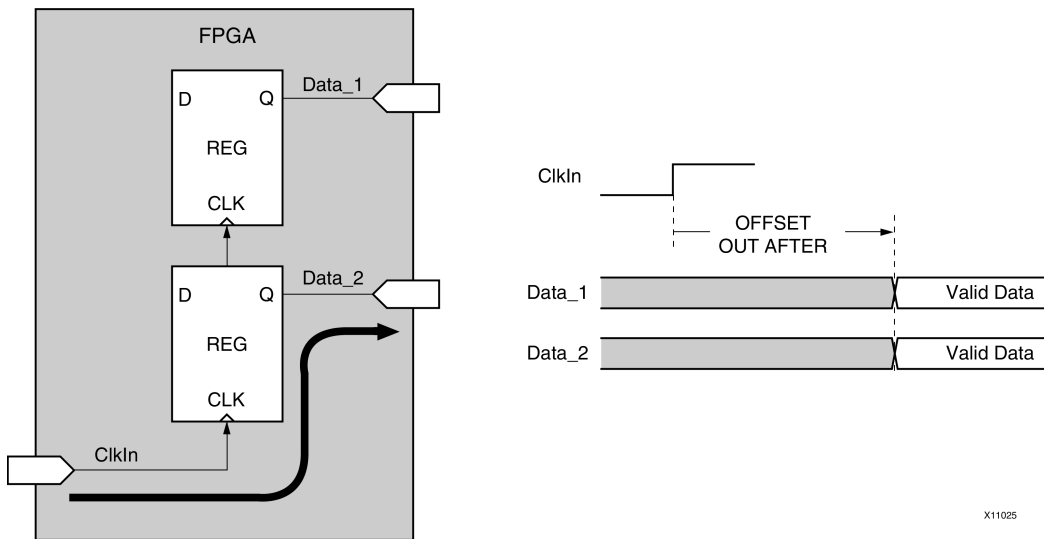

When analyzing **OFFSET OUT**, the timing analysis software automatically take all internal factors affecting the delay of the clock and software into account. These factors include:

- Frequency and phase transformations of the clock
- Clock uncertainties
- Data path delay adjustments

System Synchronous Output

The system synchronous output interface is an interface in which a common system clock is used to both transfer and capture the data. The following figure shows a simplified System Synchronous output interface with associated single data rate (SDR) timing.

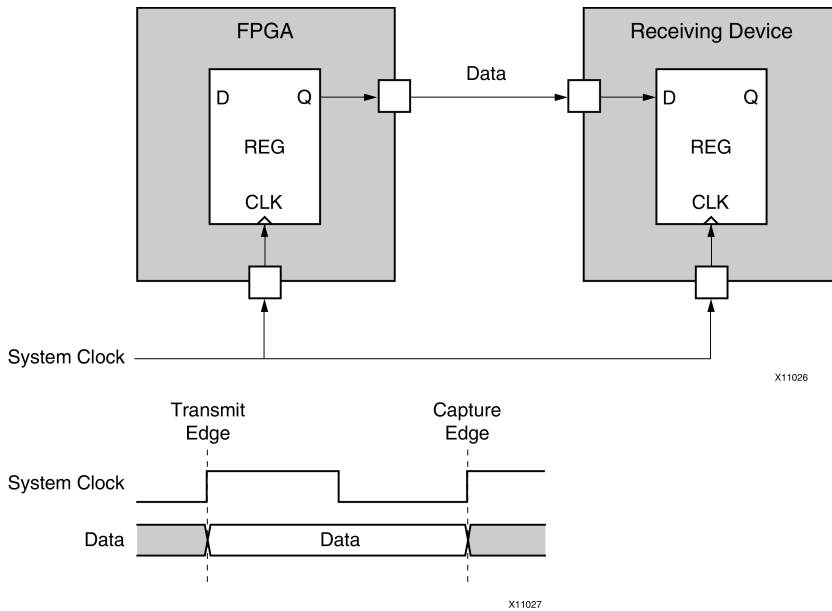

Because this interface uses a common system clock, only the data will be transmitted from the FPGA device to the receiving device.

Using **OFFSET OUT** is the most efficient way to specify the output timing for the system synchronous interface. In the global method, one **OFFSET OUT** constraint is defined for each system synchronous output interface clock. This single constraint covers the paths of all output data bits sent from registers triggered by the specified output clock.

To specify the output timing:

1. Define a time name (**TNM**) for the output clock to create a **timegroup** which contains all output registers triggered by the output clock.
2. Define the global the **OFFSET OUT** constraint for the interface

Example

The following example shows the interface and a timing diagram for a System Synchronous SDR output interface. The data in this example must become valid at the output pins a maximum of 5 ns after the input clock edge at the pin of the FPGA.

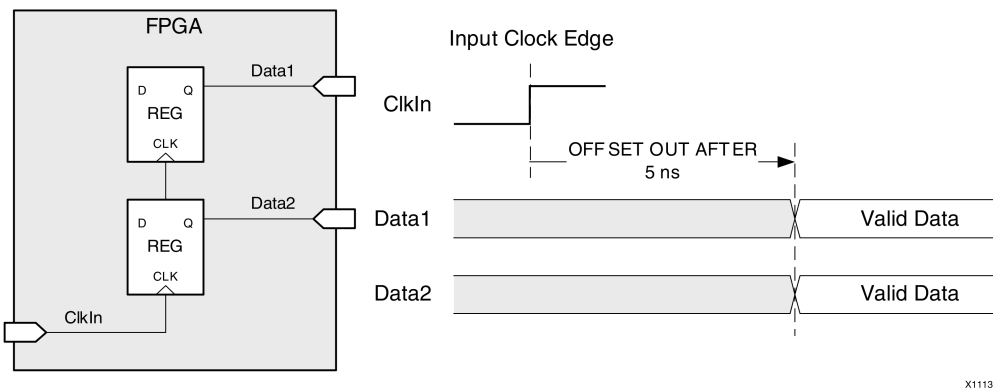

The global **OFFSET OUT** constraint for the system synchronous interface is defined as:

OFFSET = OUT*value* **VALID** *value* **AFTER** *clock*;

For **OFFSET OUT**, the **OFFSET=OUT** *value* determines the maximum time from the rising clock edge at the input clock port until the data first becomes valid at the data output port of the FPGA. In this system synchronous example, the output data must become valid at least 5 ns after the input clock edge. For this example, the complete **OFFSET OUT** specification is:

```
NET "ClkIn" TNM_NET = "ClkIn";
```

```
OFFSET = OUT 5 ns AFTER "ClkIn";
```

This global constraint covers both output data bits of the bus:

- **data1**
- **data2**

Source Synchronous Outputs

The source synchronous output interface is an interface in which a clock is regenerated and transmitted along with the data from the FPGA device. The following figure shows a simplified Source Synchronous output interface with associated DDR timing.

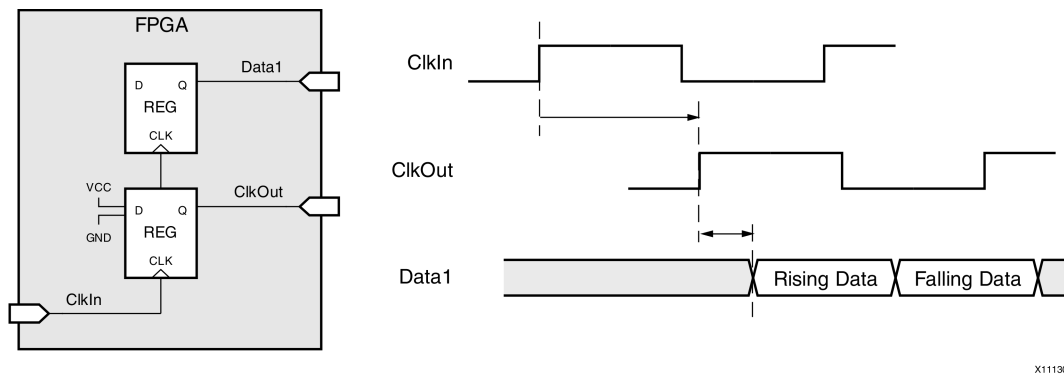

Because the regenerated clock is transmitted along with the data, the interface is primarily limited in performance by system noise and the skew between the regenerated clock and the data bits. In this interface, the time from the input clock edge to the output data becoming valid is not as important as the skew between the output data bits and in most cases can be left unconstrained.

Using **OFFSET OUT** is the most efficient way to specify the output timing for a source synchronous interface. In the DDR interface, one **OFFSET OUT** constraint is defined for each edge of the output interface clock. These constraints cover the paths of all output data bits that are transmitted by registers triggered with the specified output clock edge.

To specify the output timing:

1. Define a time name (**TNM**) for the output clock to create a **timegroup** which contains all output registers triggered by the output clock
2. Define the global **OFFSET OUT** constraint for the rising edge of the interface
3. Define the global **OFFSET OUT** constraint for the falling edge of the interface

Example

The following example shows a timing diagram for an ideal Source Synchronous DDR interface. In this interface example the absolute clock to output time is not important, and only the skew between the regenerated clock and the output data bits is desired.

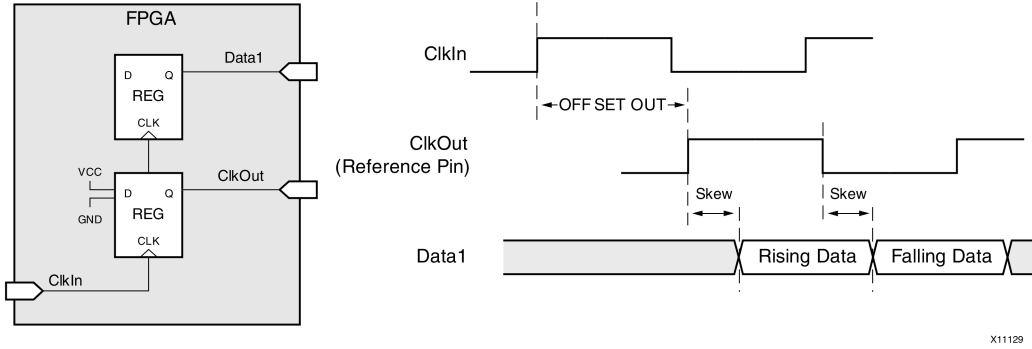

The global OFFSET OUT constraints for the DDR case are:

OFFSET = OUT AFTER_{clock} REFERENCE_PIN "REF_CLK" RISING;

OFFSET = OUT AFTER_{clock} REFERENCE_PIN "REF_CLK" FALLING;

For **OFFSET OUT**, the **OFFSET=OUT value** determines the maximum time from the rising clock edge at the input clock port until the data first becomes valid at the data output port of the FPGA device. When the value is omitted from **OFFSET OUT**, the constraint becomes a report only specification which reports the skew of the output bus. The **REFERENCE_PIN** keyword in the constraint defines the regenerated output clock as the reference point for which the skew of the output data pins is reported against.

For this example, the complete **OFFSET OUT** specification for both the rising and falling clock edges is:

NET "ClkIn" TNM_NET = "ClkIn";

OFFSET = OUT AFTER "ClkIn" REFERENCE_PIN "ClkOut" RISING;

OFFSET = OUT AFTER "ClkIn" REFERENCE_PIN "ClkOut" FALLING;

Exception Timing Constraints

This section discusses Exception Timing Constraints and includes:

- Exception Timing Constraints Overview
- False Paths
- Multi-Cycle Paths

Exception Timing Constraints Overview

By using the global definitions of the input, register-to-register, and output timing constraints, the majority of the paths are properly constrained. However, in certain cases a small number of paths contain exceptions to the global constraint rules. The most common type of exceptions specified are:

- False Paths
- Multi-Cycle Paths

False Paths

In some cases, you may want to remove a set of paths from analysis if these paths do not affect timing performance.

One common way to specify the set of paths to remove from timing analysis is to use the **FROM-TO** constraint with the timing ignore (**TIG**) keyword. This allows you to specify a set of registers in a source time group and a set of registers in a destination time group, and to automatically remove all paths between those time groups from analysis.

To specify the timing ignore (**TIG**) constraint for this method:

1. Define a set of registers for the source time group
2. Define a set of registers for the destination time group
3. Define a **FROM-TO** constraint with a **TIG** keyword to remove the paths between the groups

Example

This example shows a hypothetical case in which a path between two registers does not affect the timing of the design, and is desired to be removed from analysis. The following figure shows a block diagram of the example circuit.

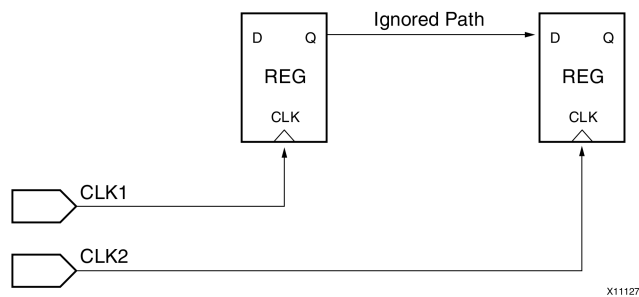

The generic syntax for defining a timing ignore (TIG) between time groups is:

```
TIMESPEC "TSid" = FROM "SRC_GRP" TO "DST_GRP" TIG;
```

In the FROM-TO TIG example, the SRC_GRP defines the set of source registers in which path tracing will begin from while the DST_GRP defines the set of destination registers the path tracing will end at. All paths that begin in the SRC_GRP and end in the DST_GRP will be ignored.

The specific syntax for this example is:

```
NET "CLK1" TNM_NET = FFS "GRP_1";
NET "CLK2" TNM_NET = FFS "GRP_2";
TIMESPEC TS_Example = FROM "GRP_1" TO "GRP_2" TIG;
```

Multi-Cycle Paths

A multi-cycle path is a path in which data is transferred from source to destination register at a rate that is less than the clock frequency defined in the PERIOD specification. This scenario most often occurs when the registers are gated with a common clock enable signal. By defining a multi-cycle path, the timing constraints for these registers will be relaxed over the default PERIOD constraint, and the implementation tools will be able to prioritize the implementation of these paths appropriately.

To specify the FROM-TO multi-cycle constraint:

1. Define a PERIOD constraint for the common clock domain
2. Define a set of registers based on a common clock enable signal
3. Define a FROM-TO multi-cycle constraint describing the new timing requirement

Example

This example shows a hypothetical case in which a path between two registers is clocked by a common clock enable signal. The clock enable is toggled at a rate that is one half of the reference clock. A block diagram of the example circuit is shown in the figure below.

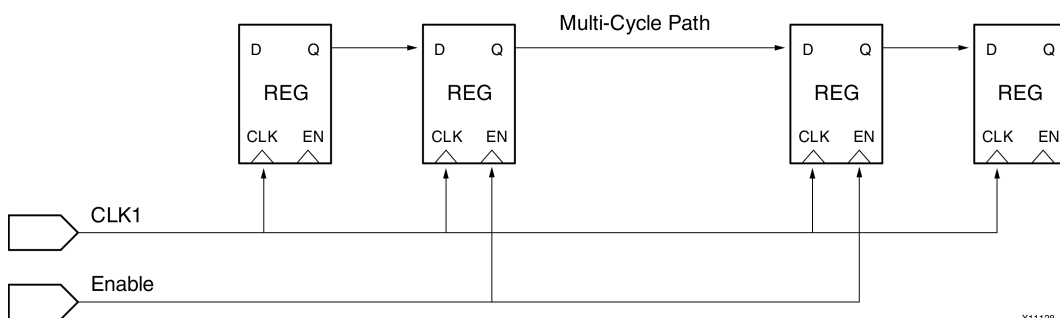

The generic syntax for defining a multi-cycle path between time groups is:

```
TIMESPEC "TSid" = FROM "MC_GRP" TO "MC_GRP" value;
```

In the FROM-TO multi-cycle example, the MC_GRP defines the set of registers which are driven by a common clock enable signal. All paths that begin in the MC_GRP and end in the MC_GRP will have the multi-cycle timing requirement applied to them while paths into and out of the MC_GRP will be analyzed with the appropriate PERIOD specification.

The specific syntax for this example is:

```
NET "CLK1" TNM_NET = "CLK1";  
TIMESPEC "TS_CLK1" = PERIOD "CLK1" 5 ns HIGH 50%;  
ET "Enable" TNM_NET = FFS "MC_GRP";  
TIMESPEC TS_Example = FROM "MC_GRP" TO "MC_GRP" TS_CLK1*2;
```

Xilinx Constraints

Each Xilinx® constraint includes the following, where applicable:

- Architecture Support
- Applicable Elements
- Description
- Propagation Rules
- Syntax
- Syntax Examples
- Additional information, if necessary

Constraint Information

This chapter gives the following information for each constraint:

- Architecture Support
Whether the constraint may be used with that device.
- Applicable Elements
The elements to which the constraint may be applied.
- Description
A brief description of the constraint, including its usage and behavior.
- Propagation Rules
How the constraint is propagated.
- Syntax Examples
Syntax examples for using the constraint with particular tools or methods. Not every tool or method is listed for every constraint. If a tool or method is not listed, the constraint may not be used with it.
- Additional Information
Additional information is provided for certain constraints.

AREA_GROUP (Area Group)

The AREA_GROUP (Area Group) constraint:

- Is a design implementation constraint.
- Enables partitioning of the design into physical regions for mapping, packing, placement, and routing.
- Is attached to logical blocks in the design.

The string value of the constraint identifies a named group of logical blocks that are to be packed together by mapper and placed in the ranges if specified by PAR. If AREA_GROUP is attached to a hierarchical block, all sub-blocks in the block are assigned to the group.

Once defined, an AREA_GROUP can have a variety of additional constraints associated with it to control its implementation. For more information, see *Constraint Syntax* below.

Architecture Support

Applies to FPGA devices. Does not apply to CPLD devices.

Applicable Elements

- Logic blocks
- Timing groups

For more information, see *Defining From Timing Groups* below.

Propagation Rules

- When attached to a design element, AREA_GROUP is propagated to all applicable elements in the hierarchy below the component.
- It is illegal to attach AREA_GROUP to a net, signal, or pin.

AREA_GROUP UCF Syntax

The UCF syntax for defining an area group is:

```
INST "X " AREA_GROUP=groupname ;
```

The UCF syntax for attaching constraints to an area group is:

```
AREA_GROUP "groupname" RANGE=range;
```

or

```
AREA_GROUP "groupname" COMPRESSION=percent;
```

or

```
AREA_GROUP "groupname" GROUP={OPEN|CLOSED};
```

or

```
AREA_GROUP "groupname" PLACE={OPEN|CLOSED};
```

where

groupname is the name assigned to an implementation partition to uniquely define the group.

Each of these additional AREA_GROUP constraints is described below.

RANGE

RANGE defines the range of device resources that are available to place logic contained in the AREA_GROUP, in the same manner ranges are defined for the LOC constraint.

For all FPGA devices, the RANGE syntax is as follows:

```
RANGE=SLICE_X# Y#:SLICE_X#Y#
```

```
RANGE=RAMB16_X#Y#:RAMB16_X#Y#
```

```
RANGE=MULT18X18_X #Y#:MULT18X18_X#Y#
```

All FPGA devices SLICES are supported. If an AREA_GROUP contains both Block RAM and SLICE elements, two separate AREA_GROUP RANGE components can be specified: one for BRAM elements and one for SLICE elements.

All locations in the FPGA device are specified in terms of X and Y coordinates. You can use the wildcard character for either the X coordinate or the Y coordinate.

The RANGE value can also be specified as a CLOCK REGION element or a set of CLOCK REGION elements. This syntax is supported for all INST types that can be used in AREA_GROUP constraints.

For all FPGA devices, AREA_GROUP is supported for various clock regions:

For a single region:

```
AREA_GROUP "groupname" RANGE=CLOCKREGION_X#Y#;
```

For a range of clock regions that form a rectangle:

```
AREA_GROUP "group_name"
RANGE=CLOCKREGION_X#Y#:CLOCKREGION_X#Y#;
```

For a list of clock regions:

```
AREA_GROUP "groupname"
RANGE=CLOCKREGION_X#Y#,CLOCKREGION_X#Y#,...;
```

The valid X# and Y# values vary by device.

Note All components can be constrained by the CLOCKREGION range except IOB and BUF.

Comma Separated RANGE Specifications Are Ignored

Comma separated RANGE specifications are not allowed on a single line. The second specification will be ignored. Each RANGE specification must be on its own line.

Following is an *invalid* syntax example.

```
INST "RM_data_control" AREA_GROUP = "RR_RM_data_control" ;
AREA_GROUP "RR_RM_data_control" RANGE = SLICE_X0Y44:SLICE_X27Y20, DSP48_X0Y25:DSP48_X0Y14;
```

Following is a *valid* syntax example.

```
INST "RM_data_control" AREA_GROUP = "RR_RM_data_control" ;
AREA_GROUP "RR_RM_data_control" RANGE = SLICE_X0Y44:SLICE_X27Y20;
AREA_GROUP "RR_RM_data_control" RANGE = DSP48_X0Y25:DSP48_X0Y14;
```

Types of Logic Legal in the RANGE Constraint

Range Name	virtex4	virtex5	virtex6	spartan6
BSCAN_XnYn	X	X	X	X
BUFDS_XnYn		X		X
BUFGCTRL_XnYn	X	X	X	

Range Name	virtex4	virtex5	virtex6	spartan6
BUFGMUX_XnYn				X
BUFHCE_XnYn			X	
BUFH_XnYn				X
BUFIO2FB_XnYn				X
BUFIO2_XnYn				X
BUFIODQS_XnYn			X	
BUFIO_XnYn	X	X		
BUFO_XnYn			X	
BUFPLL_MCB_XnYn				X
BUFPLL_XnYn				X
BUFR_XnYn	X	X	X	
CAPTURE_XnYn			X	
CFG_IO_ACCESS_XnYn			X	
CRC32_XnYn		X		
CRC64_XnYn		X		
DCIRESET_XnYn			X	
DCI_XnYn	X	X	X	
DCM_ADV_XnYn	X	X		
DCM_XnYn				X
DNA_PORT_XnYn			X	
DPM_XnYn	X			
DSP48_XnYn	X	X	X	X
EFUSE_USR_XnYn			X	
EMAC_XnYn	X			
FIFO16_XnYn	X			
GLOBALSIG_XnYn	X	X	X	
GT11CLK_XnYn	X			
GT11_XnYn	X			
GTPA1_DUAL_XnYn				X
GTP_DUAL_XnYn		X		
GTXE1_XnYn			X	
GTX_DUAL_XnYn		X		
IBUFDS_GTXE1_XnYn			X	
ICAP_XnYn	X	X	X	X
IDELAYCTRL_XnYn	X	X	X	
ILOGIC_XnYn	X	X	X	X
IOB_XnYn	X	X	X	
IODELAY_XnYn		X	X	X

Range Name	virtex4	virtex5	virtex6	spartan6
IPAD_XnYn	X	X	X	X
MCB_XnYn				X
MMCM_ADV_XnYn			X	
MONITOR_XnYn	X			
OCT_CAL_XnYn				X
OLOGIC_XnYn	X	X	X	X
OPAD_XnYn	X	X	X	X
PCIE_XnYn		X	X	X
PCILOGIC_XnYn				X
PLL_ADV_XnYn		X		X
PMCD_XnYn	X			
PMVBRAM_XnYn		X	X	
PMVIOB_XnYn			X	
PMV_XnYn			X	
PPC405_ADV_XnYn	X			
PPC440_XnYn		X		
PPR_FRAME_XnYn			X	
RAMB16_XnYn	X			X
RAMB18_XnYn			X	
RAMB36_XnYn		X	X	
RAMB8_XnYn				X
SLICE_XnYn	X	X	X	X
STARTUP_XnYn			X	
SYSMON_XnYn		X	X	
TEMAC_XnYn		X	X	
TIEOFF_XnYn	X	X	X	X
USR_ACCESS_XnYn			X	

Sites That Do Not Conform to the Normal X, Y Format

The following sites do not conform to the normal X, Y format and can be used in an area group range. The syntax is:

`AREA_GROUP "group" RANGE=site1; AREA_GROUP "group" RANGE=site2;`

Site Name	virtex4	virtex5	virtex6	spartan6
CAPTURE	X	X		
DCIRESET	X	X		
DNA_PORT				X
EFUSE_USR		X		
FRAME_ECC	X	X	X	
JTAGPPC	X	X		
KEY_CLEAR		X		
PAD				X
PMV	X	X		X
POST_CRC_INTERNAL				X
SLAVE_SPI				X
SPI_ACCESS				X
STARTUP	X	X		X
SUSPEND_SYNC				X
USR_ACCESS_SITE	X	X		

COMPRESSION

COMPRESSION defines the compression factor for the AREA_GROUP constraints. The percent values can be from 0 to 100. If the AREA_GROUP does not have a RANGE, only 0 (no compression) and 1 (maximum compression) are meaningful. The mapper computes the number of CLBs in the AREA_GROUP from the RANGE and attempts to compress the logic into the percentage specified. Compression does not apply to BRAMs, or DSP block/multipliers.

The compression factor is similar to the `-c` option in MAP, except that it operates on the AREA_GROUP instead of the whole design. AREA_GROUP compression interacts with the `-c` map option as follows:

- Area groups with a compression factor are not affected by the `-c` option. (Logic that is not part of an area group is not merged with grouped logic if the AREA_GROUP has its own compression factor.)
- Area groups without a compression factor are affected by the `-c` option. The mapper may attempt to combine ungrouped logic with logic that is part of an area group without a compression factor.
- At no time is the logic from two separate area groups combined.
- The `-c` map option does not force compression among slices in the same area group.

The Map Report (MRP) includes a section that summarizes AREA_GROUP processing.

If a symbol that is part of an AREA_GROUP contains a **LOC (Location)** constraint, the mapper removes the symbol from the area group and processes the LOC constraint.

Logic that does not belong to any AREA_GROUP can be pulled into the region of logic belonging to an area group, as well as being packed or merged with such logic to form SLICES.

COMPRESSION on AREA_GROUP constraints does not apply when Timing Driven Packing and Placement is in MAP(-timing).

COMPRESSION on AREA_GROUP constraints is not supported for Virtex®-5 devices.

GROUP

GROUP controls the packing of logic into physical components (that is, slices) as follows.

- CLOSED
Do not allow logic *outside* the AREA_GROUP to be combined with logic *inside* the AREA_GROUP.
- OPEN
Allow logic *outside* the AREA_GROUP to be combined with logic *inside* the AREA_GROUP.
The default value is **GROUP=OPEN**.

PLACE

PLACE controls the allocation of resources in the area group's RANGE, as follows.

- CLOSED
Do not allow comps that are not members of the AREA_GROUP to be placed within the RANGE defined for the AREA_GROUP.
- OPEN
Allow comps that are not members of the AREA_GROUP to be placed within the RANGE defined for the AREA_GROUP.
The default value is **PLACE=OPEN**.

Syntax Examples

The following examples show how to use this constraint with particular tools or methods. If a tool or method is not listed, you cannot use this constraint with it.

Schematic Syntax Examples

- Attach **AREA_GROUP**=*groupname* to a valid instance.
- Attach **RANGE** =*range* to a CONFIG symbol.
- Attach **COMPRESSION**=*percent* to a CONFIG symbol.
- Attach **GROUP**=**{OPEN | CLOSED}** to a CONFIG symbol.
- Attach **PLACE**=**{OPEN | CLOSED}** to a CONFIG symbol.
- Attach to a CONFIG symbol. For a value of **TRUE**, both **PLACE** and **GROUP** must be **CLOSED**.
- Attribute Names
 - **AREA_GROUP**
 - **RANGE** *range*
 - **COMPRESSION** *percent*
 - **GROUP**=**{OPEN | CLOSED}**
 - **PLACE**=**{OPEN | CLOSED}**
- Attribute Values:
 - *groupname*
 - *range*
 - *percent*
 - **GROUP**=**{OPEN | CLOSED}**
 - **PLACE**=**{OPEN | CLOSED}**

UCF and NCF Syntax Example

The following example:

- Assigns all the logical blocks in **state_machine_X** to the area group **group1**.
- Places logic in the physical area between:
 - **SLICE row 1, column 1**, and
 - **SLICE row 10, column 10**

```
INST "state_machine_X" AREA_GROUP=group1;AREA_GROUP "group1"RANGE=SLICE_X1Y1:SLICE_X10Y10;
```

PlanAhead Syntax

For more information about using the PlanAhead software to create constraints, see *Floorplanning the Design* in the *PlanAhead User Guide (UG632)*. See [PlanAhead](#) in this Guide for information about:

- Defining placement constraints
- Assigning placement constraints
- Defining I/O pin configurations
- Floorplanning and placement constraints

Constraints Editor Syntax

For information on setting constraints in Constraints Editor, including syntax, see the Constraints Editor Help.

Defining From Timing Groups

To create an area group based on a timing group, use the following User Constraints File (UCF) and Netlist Constraints File (NCF) syntax:

```
TIMEGRP timing_group_name AREA_GROUP = area_group_name ;
```

- *timing_group_name* is the name of a previously defined timing group.
- *area_group_name* is the name of a new area group to be defined from the **TIMEGRP** contents.

This is equivalent to manually assigning each member of the timing group to *area_group_name*. The area group name defined by this statement can be used in RANGE constraints, just like any other area group name.

TNM_NET Groups

In the AREA_GROUP definition, the *timing_group_name* is generally a **TNM_NET** group. This allows area groups to be formed based on the loads of clock or other control nets. Defining AREA_GROUP constraints from **TIMEGRP** constraints can improve placement of designs with many different clock domains in devices that have more clocks than clock regions.

TNM and TIMEGRP Groups

You can also specify

- A **TNM** group name, or
- The name of a user group defined by a **TIMEGRP** statement.

Edge qualifiers used in the TIMEGRP definition are ignored when determining area group membership. In all cases, the AREA_GROUP members are determined after the TIMEGRP has been propagated to its target elements.

TIMEGRP constraints can contain only synchronous elements and pads. Area groups defined from timing groups also contain only these element types. If an AREA_GROUP is defined by a TIMEGRP that contains only Flip-Flops or Latches, assigning a RANGE to that group is useful only if ungrouped logic is also allowed within the area. For this reason, don not define COMPRESSION for such groups.

PERIOD Specifications

If a **TNM_NET** is used by a **PERIOD** specification, and is traced into any **DCM**, **PLL**, or **MMCM**, new **TNM_NET** groups and **PERIOD** specifications are created at the **DCM**, **PLL**, or **MMCM** outputs. If the original **TNM_NET** is used to define an area group, and if more than one clock tap is used on the **DCM**, **PLL**, or **MMCM**, the area group is split into separate groups at each clock tap.

For example, assume you have the following UCF constraints:

```
NET "clk" TNM_NET="clock";  
TIMESPEC "TS_clk" = PERIOD "clock" 10 MHz;  
TIMEGRP "clock" AREA_GROUP="clock_area";
```

If the net **clk** is traced into a **DCM**, **PLL**, or **MMCM**, a new group and **PERIOD** specification is created at each clock tap. Similarly, a new area group is created at each clock tap. A suffix indicates the clock tap name. If the **CLK0** and **CLK2X** taps are used, the **AREA_GROUP** **clock_area_CLK0** and **clock_area_CLK2X** are defined automatically.

When **AREA_GROUP** definitions are split in this manner, **NGDBuild** issues an informational message, showing the names of the new groups. Use these new group names, rather than the ones originally specified, in **RANGE** constraints.

ASYNC_REG (Asynchronous Register)

The ASYNC_REG (Asynchronous Register) constraint:

- Is a timing constraint.
- Is used to improve the behavior of asynchronously clocked data for simulation.
- Disables X propagation during timing simulation. In the event of a timing violation, the previous value is retained on the output instead of going unknown.

Architecture Support

Applies to FPGA devices. Does not apply to CPLD devices.

Applicable Elements

- Can be attached to registers and latches only.
- Should be used only on registers or latches with asynchronous inputs (D input or the CE input).

Propagation Rules

Applies to the register or latch to which it is attached.

Syntax Examples

The following examples show how to use this constraint with particular tools or methods. If a tool or method is not listed, you cannot use this constraint with it.

VHDL Syntax

Declare the VHDL constraint as follows:

```
attribute ASYNC_REG : string;
```

Specify the VHDL constraint as follows:

```
attribute ASYNC_REG of instance_name: label is "{TRUE|FALSE}";
```

For more information about basic VHDL syntax, see [VHDL Attributes](#).

Verilog Syntax

Place the Verilog constraint immediately before the module or instantiation.

Specify the Verilog constraint as follows:

```
(* ASYNC_REG = " {TRUE|FALSE} " *)
```

For more information about basic Verilog syntax, see [Verilog Attributes](#).

UCF and NCF Syntax

```
INST "instance_name" ASYNC_REG = {TRUE|FALSE};
```

The default is **FALSE**.

If no Boolean value is supplied, it is considered **TRUE**.

Constraints Editor Syntax

For information on setting constraints in Constraints Editor, including syntax, see the Constraints Editor Help.

BEL (BEL)

The BEL (BEL) constraint:

- Is an advanced placement constraint.
- Locks a logical symbol to a particular BEL site in a slice, or an IOB.
- Differs from the [LOC](#) constraint in that LOC allows specification to the component level. Examples of components include:
 - SLICE
 - BRAM
 - ILOGIC
 - OLOGIC
 - IOB
- Allows specification as to which particular BEL site of the component to be used. For example, this can be used to specify the specific LUT or FF to be used within a SLICE.
- Should always be used with an appropriate [LOC](#) or [RLOC](#) attribute.

An IOB BEL constraint does not direct the mapper to pack the register into an IOB component. Some other feature (the `-pr` switch, for example) must cause the packing. Once the register is directed to an IOB, the BEL constraint causes the proper placement within the IOB.

Architecture Support

Applies to FPGA devices. Does not apply to CPLD devices.

Applicable Elements

Registers	Latches
LUT LUTRAM RAMB18	SRL

Propagation Rules

It is legal to place a BEL constraint only on an appropriate instance with a valid [LOC](#) or [RLOC](#).

Constraint Values

Value	Identify in a Slice
E, G	Specific LUTs, SRL16s, and distributed RAM components
A6LUT, B6LUT, C6LUT, D6LUT	
A5LUT, B5LUT, C5LUT, D5LUT	
FFA, FFB, FFC, FFD, FFX, FFY	Specific Flip-Flops, Latches, and other elements
XORF, XORG	XORCY elements

The following values are also valid for Virtex®-6 devices:

AFF, BFF, CFF, DFF, A5FF, B5FF, C5FF, D5FF

Syntax Examples

The following examples show how to use this constraint with particular tools or methods. If a tool or method is not listed, you cannot use this constraint with it.

Schematic Syntax

- Attach to a valid instance
- Attribute Name
BEL

Verilog Syntax

Place the Verilog constraint immediately before the module or instantiation.

Specify the Verilog constraint as follows:

```
(* BEL = " {value}" *)
```

For more information about basic Verilog syntax, see [Verilog Attributes](#).

UCF and NCF Syntax

```
INST "instance_name" BEL={value};
```

The syntax for the RAMB BEL instance is:

```
INST "upper_BRAM_instance_name" LOC = RAMB36_XnYn | BEL = UPPER;
```

```
INST "lower_BRAM_instance_name" LOC = RAMB36_XnYn | BEL = LOWER;
```

Example

```
INST "ramb18_inst0" LOC = RAMB36_X0Y2 | BEL = UPPER; INST  
"ramb18_inst1" LOC = RAMB36_X0Y2 | BEL = LOWER;
```

The following statement locks `xyzzzy` to the FFX site on the slice.

```
INST "xyzzzy" BEL=FFX;
```

PlanAhead™ Syntax

For more information about using the PlanAhead software to create constraints, see *Floorplanning the Design* in the *PlanAhead User Guide (UG632)*. See [PlanAhead](#) in this Guide for information about:

- Defining placement constraints
- Assigning placement constraints
- Defining I/O pin configurations
- Floorplanning and placement constraints

BLKNM (Block Name)

The BLKNM (Block Name) constraint:

- Is an advanced mapping constraint
- Assigns block names to qualifying primitives and logic elements.

If the same BLKNM constraint is assigned to more than one instance, the software attempts to map them into the same block. Conversely, two symbols with different BLKNM names are not mapped into the same block. Placing similar BLKNM constraints on instances that do not fit within one block causes an error.

Specifying identical BLKNM constraints on FMAP tells the software to group the associated function generators into a single SLICE. Using BLKNM, you can partition a complete SLICE without constraining the SLICE to a physical location on the device. BLKNM constraints, like [LOC](#) constraints, are specified from the design. Since hierarchical paths are not prefixed to BLKNM constraints, BLKNM constraints for different SLICES must be unique throughout the entire design. For information on attaching hierarchy to block names, see [Hierarchical Block Name \(HBLKNM\)](#).

BLKNM allows any elements except those with a different BLKNM to be mapped into the same physical component. Elements without a BLKNM can be packed with those that have a BLKNM. For information on allowing only elements with the same [XBLKNM](#) to be mapped into the same physical component, see [XBLKNM](#).

Architecture Support

Applies to FPGA devices. Does not apply to CPLD devices.

Applicable Elements

This constraint may be used with an FPGA device in one or more of the following design elements, or categories of design elements. Not all devices support all elements. To see which design elements can be used with which devices, see the *Libraries Guides*. For more information, see the device data sheet.

- Flip-flop and latch primitives
- Any I/O element or pad
- FMAP
- ROM primitives
- RAMS and RAMD primitives
- Carry logic primitives
- Block RAM

You can also attach BLKNM to the net connected to the pad component in a User Constraints File (UCF) file. NGDBuild transfers the constraint from the net to the pad instance in the NGD file so that it can be processed by the mapper. Use the following syntax:

```
NET "net_name" BLKNM=property_value;
```

Propagation Rules

When attached to a design element, this constraint is propagated to all applicable elements in the hierarchy within the design element.

Syntax Examples

The following examples show how to use this constraint with particular tools or methods. If a tool or method is not listed, you cannot use this constraint with it.

Schematic Syntax

- Attach to a valid instance
- Attribute Name
`BLKNM`
- Attribute Value
`block_name`

VHDL Syntax

Declare the VHDL constraint as follows:

```
attribute blknm : string;
```

Specify the VHDL constraint as follows:

```
attribute blknm of {component_name|signal_name|entity_name|label_name}:  
{component|signal|entity|label} is "block_name";
```

For more information about basic VHDL syntax, see [VHDL Attributes](#).

Verilog Syntax

Place the Verilog constraint immediately before the module or instantiation.

Specify the Verilog constraint as follows:

```
(* BLKNM = "blk_name" *)
```

For more information about basic Verilog syntax, see [Verilog Attributes](#).

UCF and NCF Syntax

```
INST "instance_name" BLKNM=block_name;
```

where

`block_name` is a valid block name for that type of symbol

For information on assigning hierarchical block names, see [Hierarchical Block Name \(HBLKNM\)](#).

The following statement assigns an instantiation of an element named **block1** to a block named **U1358**.

```
INST "$1I87/block1" BLKNM=U1358;
```

XCF Syntax

```
MODEL "entity_name" blknm = block_name;
```

```
BEGIN MODEL "entity_name"
```

```
INST "instance_name" blknm = block_name;
```

```
END;
```

BUFG (BUFG)

The BUFG (BUFG) constraint:

- Is an advanced fitter constraint.
- Is a synthesis constraint.

When applied to an input buffer or input pad net, BUFG maps the tagged signal to a global net. When applied to an internal net, the tagged signal is either routed directly to a global net or brought out to a global control pin to drive the global net, as supported by the target device family architecture.

- **CLK**
Maps to a global clock (GCK) line
- **OE**
Maps to a global tristate control (GTS) line
- **SR**
Maps to a global set/reset control (GSR) line
- **DATA_GATE**
Maps to the DATA_GATE latch enable control line

Architecture Support

Applies to CPLD devices only. Does not apply to FPGA devices.

Applicable Elements

Any input buffer (IBUF), input pad net, or internal net that drives a CLK, OE, SR, or DATA_GATE pin

Propagation Rules

When attached to a net, BUFG has a net or signal form and so no special propagation is required. When attached to a design element, BUFG is propagated to all applicable elements in the hierarchy within the design element.

Syntax Examples

The following examples show how to use this constraint with particular tools or methods. If a tool or method is not listed, you cannot use this constraint with it.

Schematic Syntax

- Attach to an IBUF instance of the input pad connected to an IBUF input
- Attribute Name
BUFG

VHDL Syntax

Declare the VHDL constraint as follows:

attribute BUFG: string;

Specify the VHDL constraint as follows:

attribute BUFG of *signal_name* : signal is "{CLK|OE|SR|DATA_GATE}";

For more information about basic VHDL syntax, see [VHDL Attributes](#).

Verilog Syntax

Place the Verilog constraint immediately before the module or instantiation.

Specify the Verilog constraint as follows:

```
(* BUFG = "{CLK | OE | SR | DATA_GATE}" *)
```

For more information about basic Verilog syntax, see [Verilog Attributes](#).

UCF and NCF Syntax

```
NET "net_name" BUFG={CLK | OE | SR | DATA_GATE};
```

```
INST "instance_name" BUFG={CLK | OE | SR | DATA_GATE};
```

where

- **CLK**
Designates a global clock pin (all CPLD families)
- **OE**
Designates a global tristate control pin (all CPLD devices except CoolRunner™-II and CoolRunner XPLA3 devices) or internal global tristate control line (CoolRunner-II devices only)
- **SR**
Designates a global set/reset pin (all CPLD devices except CoolRunner-II and CoolRunner XPLA3 devices)
- **DataGate**
Maps to the **DataGate** latch enable control line

The following statement maps the signal named **fastclk** to a global clock net.

```
NET "fastclk" BUFG=CLK;
```

XCF Syntax

```
BEGIN MODEL "entity_name"
```

```
NET "signal_name" BUFG = {CLK | OE | SR | DATA_GATE} ;
```

```
END;
```

Clock Dedicated Route (CLOCK_DEDICATED_ROUTE)

The Clock Dedicated Route (CLOCK_DEDICATED_ROUTE) constraint:

- Is an advanced constraint.
- Directs the tools whether or not to follow clock placement rules for a specific architecture.

If the constraint is not used or set to **TRUE**, clock placement rules must be followed. Otherwise, placement will error. If the constraint is set to **FALSE**, it directs the tools to ignore the specific clock placement rule and continue with Place and Route (PAR). If possible, all clock placement rule violations should be fixed in a design in order to ensure the best clocking performance. This constraint is intended to be used only in limited situations when it is absolutely necessary to violate a clock placement rule. For more information about specific clock placement rules, see the *Hardware User's Guide*.

Architecture Support

Applies to FPGA devices. Does not apply to CPLD devices.

Applicable Elements

Applies to Clock Buffers, Clock Manager Blocks, and High Speed IO Blocks.

Propagation Rules

Applies to the NET or INSTANCE PIN.

Syntax

The following sections show the syntax for this constraint.

Syntax Examples

The following examples show how to use this constraint with particular tools or methods. If a tool or method is not listed, you cannot use this constraint with it.

Schematic Syntax

- Attach to a valid instance
- Attribute Name
CLOCK_DEDICATED_ROUTE
- Attribute Values
 - **TRUE**
 - **FALSE**

UCF and NCF Syntax

```
PIN "BEL_INSTANCE_NAME.PIN" CLOCK_DEDICATED_ROUTE = {TRUE|FALSE};
```

where

BEL_INSTANCE_NAME.PIN is the specific input/output pin of the instance you want to constrain. An example is the **CLKIN** input pin of a **DCM** instance.

COLLAPSE (Collapse)

The COLLAPSE (Collapse) constraint:

- Is an advanced fitter constraint.
- Forces a combinatorial node to be collapsed into all of its fanouts.

Architecture Support

Applies to CPLD devices only. Does not apply to FPGA devices.

Applicable Elements

Any internal net.

Propagation Rules

This constraint is a net constraint. Any attachment to a design element is illegal.

Syntax Examples

The following examples show how to use this constraint with particular tools or methods. If a tool or method is not listed, you cannot use this constraint with it.

Schematic Syntax

- Attach to a logic symbol or its output net
- Attribute Name
COLLAPSE
- Attribute Values
 - **TRUE**
 - **FALSE**

VHDL Syntax

Declare the VHDL constraint as follows:

```
attribute collapse: string;
```

Specify the VHDL constraint as follows:

```
attribute collapse of signal_name: signal is "{YES|NO|TRUE|FALSE}";
```

For more information about basic VHDL syntax, see [VHDL Attributes](#).

Verilog Syntax

Place the Verilog constraint immediately before the module or instantiation.

Specify the Verilog constraint as follows:

```
(* COLLAPSE = "{YES|NO|TRUE|FALSE}" *)
```

For more information about basic Verilog syntax, see [Verilog Attributes](#).

UCF and NCF Syntax

```
NET "net_name" COLLAPSE;
```

The following statement forces net \$1N6745 to collapse into all its fanouts.

```
NET "$1I87/$1N6745" COLLAPSE;
```

COMPGRP (Component Group)

The COMPGRP (Component Group) constraint:

- Is an advanced grouping constraint
- Identifies a group of components

Architecture Support

Applies to FPGA devices. Does not apply to CPLD devices.

Applicable Elements

Groups of components.

Syntax Examples

The following examples show how to use this constraint with particular tools or methods. If a tool or method is not listed, you cannot use this constraint with it.

PCF Syntax

```
COMPGRP "group_name"=comp_item1... comp_itemn [EXCEPT comp_group];
```

where

comp_item is one of the following

- COMP "*comp_name*"
- COMPGRP "*group_name*"

CONFIG_MODE (Configuration Mode)

The CONFIG_MODE (Configuration Mode) constraint:

- Communicates to PAR which of the dual purpose configuration pins can be used as general purpose IOs.
- Is used by PAR to prohibit the use of Dual Purpose IOs if they are required for **CONFIG_MODE: S_SELECTMAP+READBACK** or **M_SELECTMAP+READBACK**. The **bitgen -g Persist** option must be used to retain these IO for Readback and Reconfiguration use.

In the case of **CONFIG_MODE: S_SELECTMAP** or **M_SELECTMAP**, PAR uses the Dual Purpose IOs as General Purpose IOs only if necessary.

Architecture Support

Applies to Spartan®-3, Virtex®-4, Virtex-5, Virtex-6, and 7 series devices.

Applicable Elements

Attaches to the CONFIG symbol.

Propagation Rules

Applies to dual-purpose I/Os.

Syntax Examples

The following examples show how to use this constraint with particular tools or methods. If a tool or method is not listed, you cannot use this constraint with it.

UCF Syntax

```
CONFIG CONFIG_MODE=string;
```

where

string can be one of the following:

- **M_SERIAL**
Master Serial Mode (The default value)
- **S_SERIAL**
Slave Serial Mode
- **B_SCAN**
Boundary Scan Mode
- **B_SCAN+READBACK**
Boundary Scan Mode with Persist expected.
- **M_SELECTMAP**
Master SelectMAP Mode , 8-bit width
- **M_SELECTMAP+READBACK**
Master SelectMAP Mode, 8-bit width, with Persist expected.
- **S_SELECTMAP**
Slave SelectMAP Mode, 8-bit width
- **S_SELECTMAP+READBACK**
Slave SelectMAP Mode, 8-bit width, with Persist expected.

- **S_SELECTMAP16**
Slave SelectMAP Mode, 16-bit width
- **S_SELECTMAP16+READBACK**
Slave SelectMAP Mode, 16-bit width, with Persist expected.
- **S_SELECTMAP32**
Slave SelectMAP Mode, 32-bit width
- **S_SELECTMAP32+READBACK**
Slave SelectMAP Mode with Persist expected.

For **S_SELECTMAP32** and **S_SELECTMAP32+READBACK**, you can select **S_SELECTMAP16** and **S_SELECTMAP16+READBACK** for Virtex-5 devices to have the correct number of data pins needed persisting after configuration.

In addition, the following values are applicable to 7 series devices only:

- **SPIx1**
Serial Peripheral Interface, 1-bit width
- **SPIx2**
Serial Peripheral Interface, 2-bit width
- **SPIx4**
Serial Peripheral Interface, 4-bit width
- **BPI8**
Byte Peripheral Interface (Parallel NOR), 8-bit width
- **BPI16**
Byte Peripheral Interface (Parallel NOR), 8-bit width

COOL_CLK (CoolCLOCK)

COOL_CLK (CoolCLOCK) reduces clocking power within a CPLD device by combining clock division circuitry with the **DualEDGE** circuitry. Because the clock net can be a significant power drain, the clock power can be reduced by driving the net at half frequency, then doubling the clock rate using **DualEDGE** triggered macrocells.

Architecture Support

Applies to CoolRunner™-II devices only.

Applicable Elements

Applies to any input pad or internal signal driving a register clock.

Propagation Rules

Applying COOL_CLK to a clock net is equivalent to passing the clock through a divide-by-two clock divider (CLK_DIV2) and replacing all flip-flops controlled by that clock with **DualEDGE** flip-flops. Using COOL_CLK does not alter your overall design functionality.

Some restrictions apply:

- You cannot use COOL_CLK on a clock that triggers any flip-flop on the low-going edge. The CoolRunner™-II clock divider can be triggered only on the high-rising edge of the clock signal.
- If there are any **DualEDGE** flip-flops in your design source, the clock that controls any of them cannot be specified as a COOL_CLK.
- If there is already a clock divider in your design source, you cannot also use COOL_CLK. CoolRunner-II devices contain only one clock divider.

Syntax Examples

The following examples show how to use this constraint with particular tools or methods. If a tool or method is not listed, you cannot use this constraint with it.

Schematic Syntax

- Attach to a input pad or internal signal driving a register clock
- Attribute Name
COOL_CLK
- Attribute Values
 - TRUE
 - FALSE

VHDL Syntax

Declare the VHDL constraint as follows:

```
attribute cool_clk: string;
```

Specify the VHDL constraint as follows:

```
attribute cool_clk of signal_name: signal is "{TRUE | FALSE}";
```

For more information about basic VHDL syntax, see [VHDL Attributes](#).

Verilog Syntax

Place the Verilog constraint immediately before the module or instantiation.

Specify the Verilog constraint as follows:

```
(* COOL_CLK = "{TRUE | FALSE}" *)
```

For more information about basic Verilog syntax, see [Verilog Attributes](#).

UCF and NCF Syntax

```
NET "signal_name" COOL_CLK;
```

DATA_GATE (Data Gate)

DATA_GATE (Data Gate) provides a direct means of reducing power consumption. Each I/O pin input signal passes through a latch that can block the propagation of incident transitions during periods when such transitions are not of interest to your CPLD design. Input transitions that do not affect the CPLD design function still consume power, if not latched, as they are routed among the device's function blocks. By asserting the DATA_GATE control I/O pin on the device, selected I/O pin inputs become latched, thereby eliminating the power dissipation associated with external transitions on those pins.

Architecture Support

Applies to CoolRunner™-II devices with 128 macrocells or more only.

Applicable Elements

I/O pads and pins

Propagation Rules

Applying the DATA_GATE attribute to any I/O pad indicates that the pass-through latch on that device pin is to respond to the DATA_GATE control line. Any I/O pad (except the DATA_GATE control I/O pin itself), including clock input pads, can be configured to get latched by applying the DATA_GATE attribute. All other I/O pads that do not have a DATA_GATE attribute remain unlatched at all times. The DATA_GATE control signal itself can be received from off-chip via the DATA_GATE I/O pin, or you can generate it in your design based on inputs that remain unlatched (pads without DATA_GATE attributes).

For more information on using DATA_GATE with Verilog and VHDL designs, see [BUFG \(BUFG\)](#).

Syntax Examples

The following examples show how to use this constraint with particular tools or methods. If a tool or method is not listed, you cannot use this constraint with it.

Schematic Syntax

- Attach to I/O pads and pins
- Attribute Name
DATA_GATE
- Attribute Values
 - TRUE
 - FALSE

VHDL Syntax

Declare the VHDL constraint as follows:

```
attribute DATA_GATE : string;
```

Specify the VHDL constraint as follows:

```
attribute DATA_GATE of signal_name: signal is "{TRUE|FALSE}";
```

For more information about basic VHDL syntax, see [VHDL Attributes](#).

Verilog Syntax

Place the Verilog constraint immediately before the module or instantiation.

Specify the Verilog constraint as follows:

```
(* DATA_GATE = "{TRUE|FALSE}" *)
```

For more information about basic Verilog syntax, see [Verilog Attributes](#).

UCF and NCF Syntax

```
NET "signal_name" DATA_GATE;
```

XCF Syntax

```
BEGIN MODEL "entity_name"
```

```
NET "signal_name" data_gate={TRUE|FALSE};
```

```
END ;
```

DCI Cascade (DCI_CASCADE)

In Virtex®-5 and Virtex-6 device families, IO banks that need DCI reference voltage can be cascaded with other DCI IO banks. One set of VRN/VRP pins can be used to provide reference voltage to several IO banks. This results in more usable pins and in reduced power usage because fewer VR pins and DCI controllers are used. DCI Cascade (DCI_CASCADE) identifies a DCI master bank and its corresponding slave banks. There can be multiple instances of this constraint for a design in order to specify multiple master-slave pairs. BitGen uses information from this constraint to program DCI controllers for different banks and have them cascade up or down. The placer also uses this information to determine whether VR pins in slave banks can be used for other purposes.

Each instance of DCI_CASCADE must have one master bank and one or more slave banks that can be entered as a space-separated list. The first value in the list is the master bank and all subsequent values are slave banks that get DCI reference voltage from the master bank. This restriction does not apply to Virtex-6 devices. Cascaded banks must be in the same column (left, center or right) and must have the same VCCO setting. For more information, see *UCF and NCF Syntax* below.

Architecture Support

Applies to Virtex-5 and Virtex-6 devices only.

Applicable Elements

A DCI_CASCADE attribute on the top level design block.

Propagation Rules

Placed as an attribute on the CONFIG block, and propagated to the physical design object.

Syntax Examples

The following examples show how to use this constraint with particular tools or methods. If a tool or method is not listed, you cannot use this constraint with it.

UCF and NCF Syntax

```
CONFIG DCI_CASCADE = "<master> <slave1> <slave2> ...";
```

where

- <master> = [1...MAX_NUM_BANKS]
- <slave1> = [1...MAX_NUM_BANKS]
- <slave2> = [1...MAX_NUM_BANKS]
- All values in the list are legitimate IO banks in the Virtex-5 device.
- The master bank must have an IOB with an IO standard that requires DCI reference voltage. This restriction does not apply to Virtex-6 devices.
- All slave banks must have the same VCCO setting as the master bank.
- If there are banks between the master and slave, they should be able to cascade in the required direction.

Example

```
CONFIG DCI_CASCADE = "11 13 15 17";
```

PCF Syntax

CONFIG DCI_CASCADE = "<master>, <slave1>, <slave2>, ..."

where

- <master> = [1...MAX_NUM_BANKS]
- <slave1> = [1...MAX_NUM_BANKS]
- <slave2> = [1...MAX_NUM_BANKS]

DCI Value (DCI_VALUE)

DCI Value (DCI_VALUE) determines which buffer behavioral models are associated with the IOBs of a design in the generation of an IBS file using IBISWriter.

Architecture Support

Supports Virtex®-4, Virtex-5, Virtex-6, and Spartan®-3 devices.

Applicable Elements

IOBs

Propagation Rules

Applies to the IOB to which it is attached.

Syntax Examples

The following examples show how to use this constraint with particular tools or methods. If a tool or method is not listed, you cannot use this constraint with it.

UCF and NCF Syntax

```
INST pin_name DCI_VALUE = integer;
```

where

- Legal values are integers 25 through 100 with an implied units of ohms.
- The default value is 50 ohms.

Default (DEFAULT)

The Default (DEFAULT) constraint allows you to set a new default value for several constraints. A specific constraint overrides the DEFAULT constraint value where applicable.

Termination is the constraint name for the following:

- [KEEPER](#)
- [FLOAT](#)
- [PULLDOWN](#)
- [PULLUP](#)

Architecture Support

The DEFAULT constraint applies to the following constraints and their architectures:

- [KEEPER](#), [PULLDOWN](#)
Applies to all FPGA devices and the CoolRunner™-II CPLD device.
- [PULLUP](#)
Applies to all FPGA devices and the CoolRunner XPLA3 and CoolRunner-II CPLD devices.

Applicable Elements

For the applicable elements for each of the constraints supported by DEFAULT, see:

- [KEEPER](#)
- [FLOAT](#)
- [PULLDOWN](#)
- [PULLUP](#)

Propagation Rules

For the propagation rules for each of the constraints supported by DEFAULT, see:

- [KEEPER](#)
- [FLOAT](#)
- [PULLDOWN](#)
- [PULLUP](#)

Constraint Syntax

For the syntax rules for each of the constraints supported by DEFAULT, see:

- [KEEPER](#)
- [FLOAT](#)
- [PULLDOWN](#)
- [PULLUP](#)

Syntax Examples

The following examples show how to use this constraint with particular tools or methods. If a tool or method is not listed, you cannot use this constraint with it.

Schematic Syntax

The basic syntax for attaching a DEFAULT constraint to a schematic is:

- Attach to a net, instance, or pin
- Attribute Name
DEFAULT *constraint_name*
where
constraint_name is one of the following:
 - **KEEPER**
 - **FLOAT**
 - **PULLDOWN**
 - **PULLUP**
- Attribute Values
 Determined by the *constraint_name*.

VHDL Syntax

Declare the VHDL constraint as follows:

attribute *attribute_name* : **string**;

Example

attribute **KEEPER**: **string**;

Specify the VHDL constraint as follows:

attribute *attribute_name* **of** **DEFAULT** **is** *attribute_value*;

Accepted *attribute_names* for DEFAULT are:

- **KEEPER**
- **FLOAT**
- **PULLDOWN**
- **PULLUP**

Accepted *attribute_values* depend on the attribute type as shown in the following example:

attribute **of** **DEFAULT** **KEEPER** **is** "TRUE";

Verilog Syntax

Place the Verilog constraint immediately before the module or instantiation.

Specify the Verilog constraint as follows:

(* **CONSTRAINT_NAME** = "*constraint_value*" *) **DEFAULT**

The *constraint_value* is case sensitive.

Accepted **CONSTRAINT_NAMES** for the DEFAULT constraint are:

- **KEEPER**
- **FLOAT**
- **PULLDOWN**
- **PULLUP**

Accepted *constraint_values* depend on the *constraint_name*, as shown in the following example.

Example

```
(* KEEPER = "TRUE" *) DEFAULT
```

For more information about basic Verilog syntax, see [Verilog Attributes](#).

UCF Syntax

```
DEFAULT constraint_name;
```

Accepted *constraint_names* for DEFAULT are:

- KEEPER
- FLOAT
- PULLDOWN
- PULLUP

UCF Syntax Example

```
DEFAULT KEEPER = TRUE;
```

XCF Syntax

```
BEGIN MODEL "entity_name"
```

```
DEFAULT constraint_name [attribute_value];
```

```
END;
```

Accepted *constraint_names* for DEFAULT are:

- KEEPER
- FLOAT
- PULLDOWN
- PULLUP

Accepted *attribute_values* depend on the attribute type.

XCF Syntax Example

```
BEGIN MODEL "my_design"
```

```
DEFAULT keeper = TRUE;
```

```
END;
```

NCF Syntax

Same as UCF syntax.

PlanAhead Syntax

For more information about using the PlanAhead software to create constraints, see *Floorplanning the Design* in the *PlanAhead User Guide (UG632)*. See [PlanAhead](#) in this Guide for information about:

- Defining placement constraints
- Assigning placement constraints
- Defining I/O pin configurations
- Floorplanning and placement constraints

PACE Syntax

The Pinout and Area Constraints Editor (PACE) tool:

- Is supported for CPLD devices only
- Is mainly used to assign location constraints to IOs.
- Can be used to assign certain IO properties such as IO Standards.
- Can be accessed from the **Processes** window in ISE® Design Suite.

For more information, see the PACE help, especially the topics in *Editing Pins and Areas* in the *Procedures* section.

DIFF_TERM (Diff_Term)

The DIFF_TERM (Diff_Term) constraint:

- Is a basic mapping constraint.
- Is used to turn the built-in 100 ohm differential termination on or off

Architecture Support

Applies to Spartan®-6 devices only.

Applicable Elements

Differential IO blocks such as IBUFDS_DIFF_OUT

Values

- **TRUE**
Turns the built-in 100 ohm differential termination *on*
- **FALSE**
Turns the built-in 100 ohm differential termination *off*

Syntax Examples

The following examples show how to use this constraint with particular tools or methods. If a tool or method is not listed, you cannot use this constraint with it.

Schematic Syntax

- Attribute Name
DIFF_TERM
- Attribute Values
See *Values* section above.

VHDL Syntax

Declare the VHDL constraint as follows:

Attribute DIFF_TERM: string;

Specify the VHDL constraint as follows:

attribute DIFF_TERM of *block_name*: signal is "{TRUE|FALSE}";

For more information about basic VHDL syntax, see [VHDL Attributes](#).

Verilog Syntax

Place the Verilog constraint immediately before the module or instantiation.

Specify the Verilog constraint as follows:

(* DIFF_TERM = "{TRUE|FALSE }" *)

For more information about basic Verilog syntax, see [Verilog Attributes](#).

UCF and NCF Syntax

The following statement configures the IO to use the built-in 100 ohm termination.

```
INST "IO block name" DIFF_TERM = "{TRUE|FALSE }" ;
```

XCF Syntax

```
BEGIN MODEL "entity_name"  
NET "block_name"DIFF_term=true;  
END;
```

PlanAhead Syntax

For more information about using the PlanAhead software to create constraints, see *Floorplanning the Design* in the *PlanAhead User Guide (UG632)*. See [PlanAhead](#) in this Guide for information about:

- Defining placement constraints
- Assigning placement constraints
- Defining I/O pin configurations
- Floorplanning and placement constraints

DIRECTED_ROUTING (Directed Routing)

DIRECTED_ROUTING (Directed Routing) is a means of maintaining the routing and timing for a small number of loads and sources. Use of directed routing requires that the relative position between the sources and loads be maintained exactly the same with the use of [LOC](#) or [RLOC](#) constraints as well as [BEL](#) constraints.

Architecture Support

Applies to FPGA devices. Does not apply to CPLD devices.

Applicable Elements

Applies to the net to which it is attached.

Propagation Rules

Not applicable.

Syntax Examples

The following examples show how to use this constraint with particular tools or methods. If a tool or method is not listed, you cannot use this constraint with it.

UCF and NCF Syntax

The following examples are for illustration only. They are not valid executables. Formulation of a directed routing constraint requires the placement of the source and load components in a fixed location relative to each other.

FPGA Editor Syntax

To generate directed routing constraints with FPGA Editor, select **Tools > Directed Routing Constraints**. FPGA Editor provides the following three settings for the type of placement constraint to be generated automatically on the sources and loads components.

- Do Not Generate Placement Constraint
- Use Relative Location Constraint
- Use Absolute Location Constraint

Do Not Generate Placement Constraint

“Do Not Generate Placement Constraint” generates a constraint for the routing only. It is designed to be used with existing RPMs.

```
NET "net_name" ROUTE="{2;1;-4!-1;-53320;2920;14;90;200;30;13!0;-  
2091;1480;24!0;16;-8!}";
```

Use Relative Location Constraint

“Use Relative Location Constraint” generates an RPM for the source and load components along with the routing constraint. The RPM can be relocated around the device letting the Placer make the final decision on placement.

```
NET "net_name" ROUTE="{2;1;-4!-1;-53320;2920;14;90;200;30;13!0;- 2091;1480;24!0;16;-8!}";
INST "inst1" RLOC=X3Y0;
INST "inst1" RPM_GRID=GRID;
INST "inst1" U_SET=macro name;
INST "inst1" BEL="F";
INST "inst2" RLOC=X3Y0;
INST "inst2" U_SET=macro name;
INST "inst2" BEL="G";
```

In the above example, each RLOC reference signals the launch of a new instance. Accordingly, there are three instances encompassed within this example.

Use Absolute Location Constraint

“Use Absolute Location Constraint” causes the source and load components attached to the target net to be locked in place by specifying RLOC constraints as well as an [RLOC_ORIGIN](#) constraint. Alternatively, location constraints (LOCs) can be specified manually by the user.

```
NET "net_name" ROUTE="{2;1;-4!-1;-53320;2920;14;90;200;30;13!0;- 2091;1480;24!0;16;-8!}";
INST "inst1" RLOC=X3Y0;
INST "inst1" RPM_GRID=GRID;
INST "inst1" RLOC_ORIGIN=X87Y200;
INST "inst1" U_SET=macro name;
INST "inst1" BEL="F";
INST "inst2" RLOC=X0Y1;
INST "inst2" U_SET=macro name;
INST "inst2" BEL="F";
INST "inst3" RLOC=X3Y0;
INST "inst3" U_SET=macro name;
INST "inst3" BEL="G";
```

DISABLE (Disable)

The DISABLE (Disable) constraint:

- Is a timing constraint.
- Is used to turn off specific path tracing controls.

A path tracing control is used to determine if a common type of path is enabled or disabled for timing analysis. All path tracing control statements from any source (netlist, UCF, or NCF) are passed forward to the PCF. You cannot override a DISABLE in the netlist with an [Enable \(ENABLE\)](#) in the UCF.

Architecture Support

Applies to FPGA devices. Does not apply to CPLD devices.

Applicable Elements

Global in constraints file.

Propagation Rules

Disables timing analysis of specified block delay symbol

Syntax Examples

The following examples show how to use this constraint with particular tools or methods. If a tool or method is not listed, you cannot use this constraint with it.

UCF and NCF Syntax

DISABLE=*delay_symbol_name*;

where

delay_symbol_name is the name of one of the standard block delay symbols for path tracing or a specific delay name in the data sheet

These symbols are listed in the following table. Component delay names are also supported in the Physical Constraints File (PCF).

Standard Block Delay Symbols for Path Tracing

Delay Symbol Name	Path Type	Default
reg_sr_o	Asynchronous Set/Reset to output propagation delay	Disabled
reg_sr_r	Asynchronous Set/Reset to recovery path	Disabled for Virtex®-5 and earlier architectures Enabled for Virtex-6 and Spartan®-6 architectures
reg_sr_clk	Synchronous Set/Reset to clock setup and hold checks	Enabled
lat_d_q	Data to output transparent latch delay	Disabled
lat_ce_q	Clock Enable to output transparent latch delay	Disabled
ram_we_o	RAM write enable to output propagation delay	Enabled

Delay Symbol Name	Path Type	Default
io_pad_i	IO pad to input propagation delay	Enabled
io_t_pad	IO tristate to pad propagation delay	Enabled
io_o_i	IO output to input propagation delay. Disabled for tristated IOBs.	Enabled
io_o_pad	IO output to pad propagation delay.	Enabled

PCF Syntax

Same as UCF Syntax.

DRIVE (Drive)

The DRIVE (Drive) constraint:

- Is a basic mapping directive
- Selects the output for drive strength for all supported FPGA architectures.
- Selects output drive strength (**mA**) for the SelectIO™ technology buffers that use the LVTTTL, LVCMOS12, LVCMOS15, LVCMOS18, LVCMOS25, or LVCMOS33 interface I/O standard

Architecture Support

Applies to FPGA devices. Does not apply to CPLD devices.

Applicable Elements

This constraint may be used with an FPGA device in one or more of the following design elements, or categories of design elements. Not all devices support all elements. To see which design elements can be used with which devices, see the *Libraries Guides*. For more information, see the device data sheet.

- IOB output components (such as **OBUF** and **OFD**)
- SelectIO technology output buffers with:
 - **IOSTANDARD = LVTTTL**
 - **LVCMOS15**
 - **LVCMOS18**
 - **LVCMOS25**, or
 - **LVCMOS33**
- Nets

Propagation Rules

DRIVE is illegal when attached to a net or signal, except when the net or signal is connected to a pad. In this case, DRIVE is treated as attached to the pad instance. When attached to a design element, DRIVE is propagated to all applicable elements in the hierarchy below the design element.

Syntax Examples

The following examples show how to use this constraint with particular tools or methods. If a tool or method is not listed, you cannot use this constraint with it.

Schematic Syntax

- Attach to a valid IOB output component
- Attribute Name
DRIVE
- Attribute Values

For a list of the constraint values, see the *UCF and NCF Syntax* section below.

VHDL Syntax

Declare the VHDL constraint as follows:

attribute drive: string;

Specify the VHDL constraint as follows:

attribute drive of {*component_name* | *entity_name* | *label_name*} : {**component** | **entity** | **label**} **is** "value";

For a list of the constraint values, see the *UCF and NCF Syntax* section below.

For more information about basic VHDL syntax, see [VHDL Attributes](#).

Verilog Syntax

Place the Verilog constraint immediately before the module or instantiation.

Specify the Verilog constraint as follows:

(* **DRIVE** = "value" *)

For a list of the constraint values, see the *UCF and NCF Syntax* section below.

For more information about basic Verilog syntax, see [Verilog Attributes](#).

UCF and NCF Syntax

This section gives UCF and NCF Syntax examples for the following:

- IOB Output Components (UCF)
- SelectIO Technology Output Components

IOB Output Components (UCF)

For Spartan®-3 and higher devices or Virtex®-4 and higher devices:

INST "instance_name" **DRIVE**={2|4|6|8|12|16|24};

12 mA is the default

SelectIO Technology Output Components

This section applies to the following components:

- IOBUF_SelectIO
- OBUF_SelectIO
- OBUFT_SelectIO

The following table shows syntax examples for the named standard with Spartan-3 devices and higher or Virtex-4 devices and higher. The default in each case is 12 mA.

Standard	Syntax
LVTTL	INST "instance_name" DRIVE ={2 4 6 8 12 16 24};
LVC MOS12 LVC MOS15 LVC MOS18	INST "instance_name" DRIVE ={2 4 6 8 12 16};
LVC MOS25 LVC MOS33	INST "instance_name" DRIVE ={2 4 6 8 12 16 24};

XCF Syntax

```
MODEL "entity_name" drive={2|4|6|8|12|16|24};  
BEGIN MODEL "entity_name "  
NET "signal_name" drive={2|4|6|8|12|16|24};  
END;
```

PlanAhead Syntax

For more information about using the PlanAhead software to create constraints, see *Floorplanning the Design* in the *PlanAhead User Guide (UG632)*. See [PlanAhead](#) in this Guide for information about:

- Defining placement constraints
- Assigning placement constraints
- Defining I/O pin configurations
- Floorplanning and placement constraints

DROP_SPEC (Drop Specifications)

The DROP_SPEC (Drop Specifications) constraint:

- Is an advanced timing constraint.
- Allows you to specify that a timing constraint defined in the input design should be dropped from the analysis.

Use DROP_SPEC when new specifications defined in a constraints file do not directly override all specifications defined in the input design, and some of these input design specifications need to be dropped. While this timing command is not expected to be used frequently in an input netlist or a Netlist Constraints File (NCF), it is legal. If defined in an input design DROP_SPEC must be attached to [TIMESPEC](#).

Architecture Support

Applies to all FPGA devices and all CPLD devices.

Applicable Elements

Timing constraints

Propagation Rules

It is illegal to attach this constraint to nets or macros. This constraint removes a specified timing specification.

Syntax Examples

The following examples show how to use this constraint with particular tools or methods. If a tool or method is not listed, you cannot use this constraint with it.

UCF and NCF Syntax

```
TIMESPEC "TSidentifier"=DROP_SPEC;
```

where

TSidentifier is the identifier name used for the timing specification to be removed

The following statement cancels the input design specification TS67.

```
TIMESPEC "TS67"=DROP_SPEC;
```

PCF Syntax

```
"TSidentifier" DROP_SPEC;
```

ENABLE (Enable)

The ENABLE (Enable) constraint:

- Is a timing constraint.
- Turns on specific path tracing controls.

A path tracing control is used to determine if a common type of paths is enabled or disabled for timing analysis. For more information, see [Disable \(DISABLE\)](#).

Architecture Support

Applies to FPGA devices. Does not apply to CPLD devices.

Applicable Elements

Global in constraints file

Propagation Rules

Enables timing analysis for specified path delays.

Syntax Examples

The following examples show how to use this constraint with particular tools or methods. If a tool or method is not listed, you cannot use this constraint with it.

UCF and NCF Syntax

ENABLE can be applied only to a global timespec. The UCF path tracing syntax is as follows:

```
ENABLE= delay_symbol_name ;
```

Where *delay_symbol_name* is the name of one of the standard block delay symbols for path tracing symbols shown in the following table, or a specific delay name defined in the data sheet

Standard Block Delay Symbols for Path Tracing

Delay Symbol Name	Path Type	Default
reg_sr_o	Asynchronous Set/Reset to output propagation delay	Disabled
reg_sr_r	Asynchronous Set/Reset to recovery path	Disabled for Virtex®-5 and earlier architectures Enabled for Virtex-6 and Spartan®-6 architectures
reg_sr_clk	Synchronous Set/Reset to clock setup and hold checks	Enabled
lat_d_q	Data to output transparent latch delay	Disabled
lat_ce_q	Clock Enable to output transparent latch delay	Disabled
ram_we_o	RAM write enable to output propagation delay	Enabled
io_pad_i	IO pad to input propagation delay	Enabled
io_t_pad	IO tristate to pad propagation delay	Enabled
io_o_1	IO output to input propagation delay. Disabled for tristated IOBs	Enabled
io_o_pad	IO output to pad propagation delay	Enabled

PCF Syntax

`ENABLE=delay_symbol_name ;`

`TIMEGRP name ENABLE=delay_symbol_name ;`

ENABLE_SUSPEND (Enable Suspend)

ENABLE_SUSPEND (Enable Suspend) defines the behavior of the SUSPEND power-reduction mode for the Spartan®-3A device family.

Architecture Support

Applies to Spartan-3A and Spartan-6 devices only.

Applicable Elements

This constraint is a global attribute for Spartan-3A devices and is not attached to any particular element.

Propagation Rules

This constraint is a global attribute that is attached to the entire design.

Syntax Examples

The following examples show how to use this constraint with particular tools or methods. If a tool or method is not listed, you cannot use this constraint with it.

UCF Syntax

```
CONFIG ENABLE_SUSPEND="{NO | FILTERED | UNFILTERED}";
```

ENABLE_SUSPEND values are:

- **NO** (default)
Disables this feature
- **FILTERED**
Activates the suspend feature with the glitch filter being activated (requires longer pulse width to activate)
- **UNFILTERED**
Activates the feature with the filter bypassed (quicker activation of SUSPEND)

UCF Syntax Example

```
CONFIG ENABLE_SUSPEND="FILTERED";
```

FAST (Fast)

The FAST (Fast) constraint:

- Is a basic mapping constraint.
- Increases the speed of an IOB output.
- May increase noise and power consumption.

Architecture Support

Applies to all FPGA devices and all CPLD devices.

Applicable Elements

- Output primitives
- Output pads
- Bidirectional pads

You can also attach FAST to the net connected to the pad component in a UCF file. NGDBuild transfers the constraint from the net to the pad instance in the NGD file so that it can be processed by the mapper. Use the following syntax:

```
NET "net_name" FAST;
```

Propagation Rules

FAST is illegal when attached to a net except when the net is connected to a pad. In this instance, FAST is treated as attached to the pad instance. When attached to a macro, module, or entity, FAST is propagated to all applicable elements in the hierarchy below the module.

Syntax Examples

The following examples show how to use this constraint with particular tools or methods. If a tool or method is not listed, you cannot use this constraint with it.

Schematic Syntax

- Attach to a valid instance
- Attribute Name
FAST
- Attribute Values
 - TRUE
 - FALSE

VHDL Syntax

Declare the VHDL constraint as follows:

```
attribute FAST: string;
```

Specify the VHDL constraint as follows:

```
attribute FAST of signal_name: signal is "{TRUE | FALSE}";
```

For more information about basic VHDL syntax, see [VHDL Attributes](#).

Verilog Syntax

Place the Verilog constraint immediately before the module or instantiation.

Specify the Verilog constraint as follows:

```
(* FAST = "{TRUE | FALSE}" *)
```

For more information about basic Verilog syntax, see [Verilog Attributes](#).

UCF and NCF Syntax

The following statement increases the output speed of the element **y2**:

```
INST "$1I87/y2" FAST;
```

The following statement increases the output speed of the pad to which **net1** is connected:

```
NET "net1" FAST;
```

XCF Syntax

```
BEGIN MODEL "entity_name"
```

```
NET "signal_name" fast={TRUE | FALSE};
```

```
END;
```

PlanAhead Syntax

For more information about using the PlanAhead software to create constraints, see *Floorplanning the Design* in the *PlanAhead User Guide (UG632)*. See [PlanAhead](#) in this Guide for information about:

- Defining placement constraints
- Assigning placement constraints
- Defining I/O pin configurations
- Floorplanning and placement constraints

FEEDBACK (Feedback)

The FEEDBACK (Feedback) constraint:

- Is used to define the external DCM feedback path delay when the DCM is used in board de-skew applications. The delay is defined as the maximum external path delay of the board trace and should not include any internal FPGA path delays.
- Is required for the timing tools to properly determine the DCM phase shift and analyze the associated synchronous paths.
- *input_feedback_clock_net*
The name of the input pad net used as the feedback to the DCM
- *value*
The board trace delay calculated or measured by you
- *units*
ns (default) or ps
- *output_clock_net*
The name of the output pad net driven by the DCM

Architecture Support

Applies to FPGA devices. Does not apply to CPLD devices.

Applicable Elements

Not applicable.

Propagation Rules

Both *input_feedback_clock_net* and *output_clock_net* must correspond to pad nets. If attached to any other net, an error results. The *input_feedback_clock_net* must be an input pad and *output_clock_net* must be an output pad.

Syntax Examples

The following examples show how to use this constraint with particular tools or methods. If a tool or method is not listed, you cannot use this constraint with it.

UCF Syntax

```
NET output_clock_net FEEDBACK = value
units NET input_feedback_clock_net ;
```

XCF Syntax

```
BEGIN MODEL "entity_name "
NET output_clock_net FEEDBACK = value units NET input_feedback_clock_net;
END;
```

PCF Syntax

```
BEL |COMP} output_clock_net FEEDBACK = value units {BEL |COMP}
input_feedback_clock_net;
```

Constraints Editor Syntax

For information on Constraints Editor and Constraints Editor syntax in ISE® Design Suite, see the ISE Design Suite Help.

PlanAhead Syntax

For more information about using the PlanAhead software to create constraints, see *Floorplanning the Design* in the *PlanAhead User Guide (UG632)*. See [PlanAhead](#) in this Guide for information about:

- Defining placement constraints
- Assigning placement constraints
- Defining I/O pin configurations
- Floorplanning and placement constraints

FILE (File)

When you instantiate a module that resides in another netlist, NGCBuild finds this file by looking it up by the file name. This requires the netlist to have the same name as a module that is defined in the file. To name the netlist differently than the module name, attach FILE (File) to an instance declaration. This tells NGCBuild to look for the module in the file specified.

Some Xilinx® constraints cannot be used in attributes, because they are also VHDL keywords. To avoid this problem, use a constraint alias. Each constraint has its own alias. The alias name is based on the original constraint name with a XIL prefix. For example, FILE cannot be used in attributes directly. You must use XIL_FILE instead. The existing XILFILE alias is still supported.

Architecture Support

Applies to all FPGA devices and all CPLD devices.

Applicable Elements

Instance declaration where the definition is defined in the specified file.

Propagation Rules

Applicable only on instances.

Syntax Examples

The following examples show how to use this constraint with particular tools or methods. If a tool or method is not listed, you cannot use this constraint with it.

Schematic Syntax

- Attach to a valid instance
- Attribute Name
- Attribute Values

file_name.extension

where

file_name is the name of a file that represents the underlying logic for the element carrying the constraint.

Example file types include:

- EDIF
- EDN
- NGC
- NMC

VHDL Syntax

Declare the VHDL constraint as follows:

```
attribute xilfile: string;
```

Specify the VHDL constraint as follows:

```
attribute xilfile of {instance_name|component_name} : {label|component} is "file_name";
```

For more information about basic VHDL syntax, see [VHDL Attributes](#).

Verilog Syntax

Place the Verilog constraint immediately before the module or instantiation.

Specify the Verilog constraint as follows:

```
(* XIL_FILE = "file_name" *)
```

For more information about basic Verilog syntax, see [Verilog Attributes](#).

UCF and NCF Syntax

```
INST <instance definition> FILE= <filename definition is located in>;
```

No valid syntax for UCF.

FLOAT (Float)

The FLOAT (Float) constraint:

- Is a basic mapping constraint
- Allows tristated pads to float when not being driven.

This is useful when the default termination for applicable I/Os is set to any of the following in ISE® Design Suite:

- PULLUP
- PULLDOWN
- KEEPER

Architecture Support

Applies to CoolRunner™ XPLA3 and CoolRunner-II devices only.

Applicable Elements

Applies to nets or pins.

Propagation Rules

Applies to the net or pin to which it is attached.

Syntax Examples

The following examples show how to use this constraint with particular tools or methods. If a tool or method is not listed, you cannot use this constraint with it.

Schematic Syntax

- Attach to a valid instance
- Attribute Name
FLOAT
- Attribute Values
 - TRUE
 - FALSE
 - None required. If attached, TRUE is assumed.

VHDL Syntax

Declare the VHDL constraint as follows:

```
attribute FLOAT: string;
```

Specify the VHDL constraint as follows:

```
attribute FLOAT of signal_name : signal is "{TRUE|FALSE}";
```

Verilog Syntax

Place this constraint immediately before an instantiation.

Specify the Verilog constraint as follows:

```
(* FLOAT = "{TRUE|FALSE}" *)
```

UCF and NCF Syntax

```
NET "signal_name" FLOAT;
```

XCF Syntax

```
BEGIN MODEL "entity_name"
```

```
NET "signal_name" FLOAT;
```

```
END;
```

FROM-THRU-TO (From Thru To)

The FROM-THRU-TO constraint:

- Is an advanced timing constraint,
- Is associated with the [Period](#) constraint of the high or low time.

From synchronous paths, a FROM-TO-THRU constraint controls only the setup path, not the hold path. This constraint applies to a specific path that begins at a source group, passes through intermediate points, and ends at a destination group. The source and destination groups can be either user or predefined groups. You must define an intermediate path using TPTHU before using THRU.

Architecture Support

Applies to FPGA devices. Does not apply to CPLD devices.

Applicable Elements

Predefined and user-defined groups

Propagation Rules

Applies to the specified FROM-THRU-TO path only.

Syntax Examples

The following examples show how to use this constraint with particular tools or methods. If a tool or method is not listed, you cannot use this constraint with it.

UCF and NCF Syntax

```
TIMESPEC "TSidentifier"=FROM "source_group" THRU "thru_pt1"...[THRU "thru_pt2"
...] TO "destination_group" value [Units] [DATAPATHONLY];
```

where

- *identifier* can consist of characters or underbars
- *source_group* and *destination_group* are user-defined or predefined groups
- *thru_pt1* and *thru_pt2* are intermediate points to define specific paths for timing analysis
- *value* is the delay time
- *units* can be ps, ms, ns, or micro

The **DATAPATHONLY** keyword indicates that the FROM-TO constraint does not take clock skew or phase information into consideration. This keyword results in only the data path between the groups being constrained and analyzed.

```
TIMESPEC TS_MY_PathB = FROM "my_src_grp" THRU "my_thru_pt" TO "my_dst_grp" 13.5 ns DATAPATHONLY;
```

FROM or **TO** is optional. You can have just a **FROM** or just a **TO**.

You are not required to have a **FROM**, **THRU**, or **TO**. You can have almost any combination, such as:

- **FROM-TO**
- **FROM-THRU-TO**
- **THRU-TO**
- **TO**
- **FROM**
- **FROM-THRU-THRU-THRU-TO**
- **FROM-THRU**

There is no restriction on the number of **THRU** points. The source, **THRU** points, and destination can be a net, bel, comp, macro, pin, or timegroup.

Constraints Editor Syntax

For information on setting constraints in Constraints Editor, including syntax, see the Constraints Editor Help.

PlanAhead Syntax

For more information about using the PlanAhead software to create constraints, see *Floorplanning the Design* in the *PlanAhead User Guide (UG632)*. See [PlanAhead](#) in this Guide for information about:

- Defining placement constraints
- Assigning placement constraints
- Defining I/O pin configurations
- Floorplanning and placement constraints

PCF Syntax

```
TSname=MAXDELAY FROM TIMEGRP "source" THRU TIMEGRP "thru_pt1" ...THRU  
"thru_ptn" TO TIMEGRP "destination" [DATAPATHONLY];
```

You are not required to have a **FROM**, **THRU**, and **TO**. You can have almost any combination (such as **FROM-TO**, **FROM-THRU-TO**, **THRU-TO**, **TO**, **FROM**, **FROM-THRU-THRU-THRU-TO**, and **FROM-THRU**). There is no restriction on the number of **THRU** points. The source, **THRU** points, and destination can be a net, bel, comp, macro, pin, or timegroup.

FROM-TO (From To)

The FROM-TO (From To) constraint:

- Defines a timing constraint between two groups.
- Is associated with the [Period](#) constraint of the high or low time.

A group can be user-defined or predefined. From synchronous paths, a FROM-TO constraint controls only the setup path, not the hold path.

For Virtex®-5 devices, the FROM-TO constraint controls both setup and hold paths.

Architecture Support

Applies to all FPGA devices and all CPLD devices.

Applicable Elements

Predefined and user-defined groups.

Propagation Rules

Applies to a path specified between two groups.

Syntax Examples

The following examples show how to use this constraint with particular tools or methods. If a tool or method is not listed, you cannot use this constraint with it.

UCF and NCF Syntax

```
TIMESPEC TSname=FROM "group1" TO "group2" value [DATAPATHONLY];
```

where

- **TS_{name}** must always begin with **TS**. Any alphanumeric character or underscore may follow.
- *group1* is the origin path
- *group2* is the destination path
- *value* is ns by default. Other possible values are MHz or another timing specification such as TS_C2S/2 or TS_C2S*2.

The **DATAPATHONLY** keyword indicates that the FROM-TO constraint does not take clock skew or phase information into consideration. This keyword results in only the data path between the groups being constrained and analyzed.

```
TIMESPEC TS_MY_PathA = FROM "my_src_grp" TO "my_dst_grp" 23.5 ns
DATAPATHONLY;
```

XCF Syntax

XST supports FROM-TO with the following limitations:

- FROM-THRU-TO is not supported
- Linked Specification is not supported
- Pattern matching for predefined groups is not supported:

```
TIMESPEC TS_1 = FROM FFS(machine/*) TO FFS 2 ns;
```

Constraints Editor Syntax

For information on setting constraints in Constraints Editor, including syntax, see the Constraints Editor Help.

PlanAhead Syntax

For more information about using the PlanAhead software to create constraints, see *Floorplanning the Design* in the *PlanAhead User Guide (UG632)*. See [PlanAhead](#) in this Guide for information about:

- Defining placement constraints
- Assigning placement constraints
- Defining I/O pin configurations
- Floorplanning and placement constraints

PCF Syntax

```
TSname=MAXDELAY FROM TIMEGRP "group1" TO TIMEGRP "group2" value  
[DATAPATHONLY];
```

You are not required to have a **FROM**, **THRU**, and **TO**. You can have almost any combination, such as:

- **FROM-TO**
- **FROM-THRU-TO**
- **THRU-TO**
- **TO**
- **FROM**
- **FROM-THRU-THRU-THRU-TO**
- **FROM-THRU**

There is no restriction on the number of **THRU** points. The source, **THRU** points, and destination can be any of the following:

- **net**
- **bel**
- **comp**
- **macro**
- **pin**
- **timegroup**

FSM_STYLE (FSM Style)

For information about the FSM_STYLE (FSM Style) constraint, see the *XST User Guide for Virtex-6, Spartan-6, and 7 Series Devices (UG687)*.

HBLKNM (Hierarchical Block Name)

The HBLKNM (Hierarchical Block Name) constraint:

- Is an advanced mapping constraint.
- Assigns hierarchical block names to logic elements and controls grouping in a flattened hierarchical design. When elements on different levels of a hierarchical design carry the same block name, and the design is flattened, NGCBuild prefixes a hierarchical path name to the HBLKNM value.

Like Block Name, HBLKNM forces function generators and flip-flops into the same CLB. Symbols with the same HBLKNM constraint map into the same CLB, if possible.

However, using HBLKNM instead of Block Name has the advantage of adding hierarchy path names during translation, and therefore the same HBLKNM constraint and value can be used on elements within different instances of the same design element.

Architecture Support

Applies to FPGA devices. Does not apply to CPLD devices.

Applicable Elements

HBLKNM may be used with an FPGA device in one or more of the following design elements, or categories of design elements. Not all devices support all elements. To see which design elements can be used with which device families, see the Xilinx® *Libraries Guides* for details. For more information, see the device [data sheet](#).

- Registers
- I/O elements and pads
- FMAP
- PULLUP
- ACLK
- GCLK
- BUFG
- BUFGS
- BUFGP
- ROM
- RAMS
- RAMD
- Carry logic primitives

You can also attach HBLKNM to the net connected to the pad component in a UCF file. NGCBuild transfers the constraint from the net to the pad instance in the NGD file so that it can be processed by the mapper. Use the following syntax:

```
NET "net_name" HBLKNM=property_value;
```

Propagation Rules

When attached to a design element, HBLKNM is propagated to all applicable elements in the hierarchy within the design element. However, when attached to a NET, HBLKNM is only propagated to PADs.

Syntax

The following examples show how to use this constraint with particular tools or methods. If a tool or method is not listed, you cannot use this constraint with it.

Schematic Syntax

- Attach to a valid instance
- Attribute Name
HBLKNM
- Attribute Values
block_name

VHDL Syntax

Declare the VHDL constraint as follows:

```
attribute hblknm: string;
```

Specify the VHDL constraint as follows:

```
attribute hblknm of {entity_name|component_name|signal_name|label_name}:  
{entity|component|signal|label} is "block_name";
```

where

block_name is a valid block name for that type of symbol

For more information about basic VHDL syntax, see [VHDL Attributes](#).

Verilog Syntax

Place the Verilog constraint immediately before the module or instantiation.

Specify the Verilog constraint as follows:

```
(* HBLKNM = "block_name" *)
```

block_name is a valid block name for that type of symbol

For more information about basic Verilog syntax, see [Verilog Attributes](#).

UCF and NCF Syntax

```
NET "net_name" HBLKNM=property_value;
```

```
INST "instance_name" HBLKNM=block_name;
```

block_name is a valid block name for that type of symbol

The following statement specifies that the element *this_fmap* is put into the block named group1.

```
INST "$I13245/this_fmap" HBLKNM=group1;
```

The following statement attaches HBLKNM to the pad connected to **net1**.

```
NET "net1" HBLKNM=$COMP_0;
```

Elements with the same HBLKNM are placed in the same logic block if possible. Otherwise an error occurs. Conversely, elements with different block names are not put into the same block.

HIODELAY_GROUP (HIODELAY Group)

The HIODELAY_GROUP (HIODELAY Group) constraint:

- Is a design implementation constraint.
- Groups a hierarchical set of IDELAY and IODELAYs with an IDELAYCTRL to enable automatic replication and placement of IDELAYCTRL in a design.

For more information, see the IDELAYCTRL section of the device user guide.

Architecture Support

Applies to Virtex®-4 and Virtex-5 devices. For Virtex-4 devices, HIODELAY_GROUP is supported only when using the Timing Driven Pack and Placement Option in MAP.

Applicable Elements

IDELAY, IODELAY, and IDELAYCTRL primitive instantiations

Propagation Rules

HIODELAY_GROUP can be attached only to a design element. It is illegal to attach HIODELAY_GROUP to a net, signal, or pin. To merge two or more embedded HIODELAY_GROUP constraints in your design, see [MIODELAY_GROUP \(MIODELAY Group\)](#).

Syntax Examples

The following examples show how to use this constraint with particular tools or methods. If a tool or method is not listed, you cannot use this constraint with it.

VHDL Syntax

Declare the VHDL constraint as follows:

```
attribute HIODELAY_GROUP: string;
```

Specify the VHDL constraint as follows:

```
attribute HIODELAY_GROUP of {component_name|label_name}: {component|label} is  
"group_name";
```

For a description of *group_name*, see *UCF and NCF Syntax* below.

For more information about basic VHDL syntax, see [VHDL Attributes](#).

Verilog Syntax

Place the Verilog constraint immediately before the module or instantiation.

Specify the Verilog constraint as follows:

```
(* HIODELAY_GROUP = "group_name" *)
```

For a description of *group_name*, see *UCF and NCF Syntax* below.

For more information about basic Verilog syntax, see [Verilog Attributes](#).

UCF and NCF Syntax

```
INST "instance_name" HIODELAY_GROUP = group_name;
```

where

group_name is the name assigned to a set of IDELAY or IODELAY constraints and an IDELAYCTRL to uniquely define the group.

HLUTNM (Hierarchical Lookup Table Name)

The HLUTNM (Hierarchical Lookup Table Name) constraint:

- Allows you to control the grouping of logical symbols into the LUT sites of the Virtex®-5 FPGA architectures.
- Is a string value property that is applied to two qualified symbols.
- Must be applied uniquely to two symbols within a given level of hierarchy. These two symbols are implemented in a shared LUT site within a SLICE component.
- Is functionally similar to [HBLKNM \(Hierarchical Block Name\)](#)

Architecture Support

Applies to Virtex-5 devices only.

HLUTNM Applicable Elements

HLUTNM can be applied to:

- Two symbols that:
 - Share a common hierarchy, and
 - Are unique within their level of hierarchy
- Two 5-input or smaller function generator symbols (LUT, SRL16) if the total number of unique input pins required for both symbols does not exceed 5 pins.
- A 6-input read-only function generator symbol (LUT6) in conjunction with a 5-input read-only symbol (LUT5) if:
 - The total number of unique input pins required for both symbols does not exceed 6 inputs, and
 - The lower 32 bits of the 6-input symbol programming matches all 32 bits of the 5-input symbol programming.

Propagation Rules

Can be applied to two symbols that share a common hierarchy and that are also unique within their level of hierarchy.

Syntax Examples

The following examples show how to use this constraint with particular tools or methods. If a tool or method is not listed, you cannot use this constraint with it.

Schematic Syntax

- Attach to a valid element or symbol type
- Attribute Name
HLUTNM
- Attribute Value
<user_defined>

VHDL Syntax

Declare the VHDL constraint as follows:

```
attribute hlutnm: string;
```

Specify the VHDL constraint as follows:

```
attribute hlutnm of instance_name : label is "string_value";
```

where

- *instance_name* is the instance name of an instantiated LUT, or LUTRAM.
- *string_value* is applied uniquely to two symbols within a given level of hierarchy.
 - There is no default value.
 - If the value is blank, the constraint is ignored.

For more information about basic VHDL syntax, see [VHDL Attributes](#).

Verilog Syntax

Place the Verilog constraint immediately before the module or instantiation.

Specify the Verilog constraint as follows:

```
(* HLUTNM = "string_value" *)
```

where

- *string_value* is applied uniquely to two symbols within a given level of hierarchy.
- There is no default value.
- If the value is blank, the constraint is ignored.

For more information about basic Verilog syntax, see [Verilog Attributes](#).

UCF and NCF Syntax

```
INST "symbol_name" HLUTNM=string_value ;
```

where

- *string_value* is applied uniquely to two symbols within a given level of hierarchy.
- There is no default value.
- If the value is blank, the constraint is ignored.

XCF Syntax

```
MODEL "symbol_name" hlutnm = string_value ;
```

where

- *string_value* is applied uniquely to two symbols within a given level of hierarchy.
- There is no default value.
- If the value is blank, the constraint is ignored.

H_SET (H Set)

See [HU_SET \(HU Set\)](#).

HU_SET (HU Set)

The HU_SET (HU Set) constraint:

- Is an advanced mapping constraint.
- Is defined by the design hierarchy.
- Allows you to specify a set name.

Note It is possible to have only one [H_SET](#) within a given hierarchical element, but by specifying set names, you can specify several HU_SET sets.

NGCBuild hierarchically qualifies the name of the HU_SET as it flattens the design and attaches the hierarchical names as prefixes.

Differences Between HU_SET and H_SET

HU_SET	H_SET
Has an explicit user-defined and hierarchically qualified name for the set	Has only an implicit hierarchically qualified name generated by the design-flattening program
Starts with the symbols that are assigned the HU_SET constraint	Starts with the instantiating macro one level above the symbols with the RLOC constraints

For more information about set attributes, see [Relative Location \(RLOC\)](#).

Architecture Support

Applies to FPGA devices. Does not apply to CPLD devices.

Applicable Elements

This constraint may be used with an FPGA device in one or more of the following design elements, or categories of design elements. Not all devices support all elements. To see which design elements can be used with which devices, see the *Libraries Guides*. For more information, see the device data sheet.

- Registers
- FMAP
- Macro Instance
- ROM
- RAMS, RAMD
- MULT18X18S
- RAMB4_Sm_Sn, RAMB4_Sn
- RAMB16_Sm_Sn, RAMB16_Sn
- RAMB16
- DSP48

Propagation Rules

This constraint is a design element constraint. Any attachment to a net is illegal.

Syntax Examples

The following examples show how to use this constraint with particular tools or methods. If a tool or method is not listed, you cannot use this constraint with it.

Schematic Syntax

- Attach to a valid instance
- Attribute Name
`HU_SET`
- Attribute Values
`set_name`

VHDL Syntax

Declare the VHDL constraint as follows:

```
attribute HU_SET: string;
```

Specify the VHDL constraint as follows:

```
attribute HU_SET of {component_name | entity_name | label_name} : {component | entity  
| label} is "set_name";
```

For more information about basic VHDL syntax, see [VHDL Attributes](#).

Verilog Syntax

Place the Verilog constraint immediately before the module or instantiation.

Specify the Verilog constraint as follows:

```
(* HU_SET = "set_name" *)
```

For more information about basic Verilog syntax, see [Verilog Attributes](#).

UCF and NCF Syntax

```
INST "instance_name" HU_SET=set_name ;
```

where

- `set_name` is the identifier for the set
- `set_name` must be unique among all the sets in the design

The following statement assigns an instance of the register `FF_1` to a set named `heavy_set`.

```
INST "$1I3245/FF_1" HU_SET=heavy_set;
```

XCF Syntax

```
MODEL "entity_name" hu_set={yes | no};
```

```
BEGIN MODEL "entity_name"
```

```
INST "instance_name" hu_set=yes;
```

```
END;
```

IBUF_DELAY_VALUE (Input Buffer Delay Value)

The IBUF_DELAY_VALUE (Input Buffer Delay Value) constraint:

- Is a mapping constraint.
- Adds additional static delay to the input path of the FPGA array.
- Can be applied to any input or bi-directional signal that is not directly driving a clock or IOB (Input Output Block) register.

For more information regarding the constraint of signals driving clock and IOB registers, see [IFD_DELAY_VALUE](#). IBUF_DELAY_VALUE can be set to an integer value from 0-16. The value 0 is the default value, and applies no additional delay to the input path. A larger value correlates to a larger delay added to input path. These values do not directly correlate to a unit of time but rather additional buffer delay. For more information, see the device [data sheets](#).

Architecture Support

Applies to Spartan®-3A and Spartan-3E devices.

Applicable Elements

Any top-level I/O port.

Syntax Examples

The following examples show how to use this constraint with particular tools or methods. If a tool or method is not listed, you cannot use this constraint with it.

Schematic Syntax

- Attach a new property to the top-level port of the schematic
- Attribute Name
IBUF_DELAY_VALUE
- Attribute Values
0-16

VHDL Syntax

Attach a VHDL attribute to the appropriate top-level port.

```
attribute IBUF_DELAY_VALUE : string;
```

```
attribute IBUF_DELAY_VALUE of top_level_port_name: signal is "value";
```

a valid *value* is from 0 to 16.

The following statement assigns an IBUF_DELAY_VALUE increment of 5 to the net DataIn1

```
attribute IBUF_DELAY_VALUE : string;
```

```
attribute IBUF_DELAY_VALUE of DataIn1: label is "5";
```

For more information about basic VHDL syntax, see [VHDL Attributes](#).

Verilog Syntax

Attach a Verilog attribute to the appropriate top-level port.

```
(* IBUF_DELAY_VALUE="value" *) input top_level_port_name;
```

where

A valid *value* is from 0 to 16.

The following statement assigns an IBUF_DELAY_VALUE increment of 5 to the net DataIn1.

```
(* IBUF_DELAY_VALUE="5" *) input DataIn1;
```

For more information about basic Verilog syntax, see [Verilog Attributes](#).

UCF and NCF Syntax

```
NET "top_level_port_name" IBUF_DELAY_VALUE = value;
```

where

- *value* is the numerical IBUF delay setting.
- A valid *value* is from 0 to 16.

The following statement assigns an IBUF_DELAY_VALUE increment of 5 to the net DataIn1.

```
NET "DataIn1" IBUF_DELAY_VALUE = 5;
```

IFD_DELAY_VALUE (IFD Delay Value)

The IFD_DELAY_VALUE (IFD Delay Value) constraint:

- Is a mapping constraint.
- Adds additional static delay to the input path of the FPGA array.
- Can be applied to any input or bi-directional signal which drives an IOB (Input Output Block) register.

For more information on the constraint of signals which do not drive IOB registers, see [Input Buffer Delay Value \(IBUF_DELAY_VALUE\)](#).

- Can be set to
 - an integer value from 0-8
 - **AUTO**

AUTO is the default value, and is used to guarantee that the input hold time of the destination register is met by automatically adding the appropriate amount of delay to the data path.

When IFD_DELAY_VALUE is set to 0, the data path has no additional delay added. The integers 1-8 correspond to increasing amounts of delay added to the data path. These values do not directly correlate to a unit of time but rather additional buffer delay. For more information, see the device [data sheets](#).

Architecture Support

Supports Spartan®-3A and Spartan-3E devices.

Applicable Elements

Any top-level I/O port

Propagation Rules

Although IFD_DELAY_VALUE is attached to an I/O symbol, it applies to the entire I/O component.

Syntax Examples

The following examples show how to use this constraint with particular tools or methods. If a tool or method is not listed, you cannot use this constraint with it.

Schematic Syntax

- Attach to a net
- Attribute Name
IFD_DELAY_VALUE
- Attribute Values
 - 0-8
 - **AUTO**

VHDL Syntax

Attach a VHDL attribute to the appropriate top-level port.

```
attribute IFD_DELAY_VALUE : string;
```

The following statement assigns an IFD_DELAY_VALUE increment of 5 to the net **DataIn1**:

```
attribute IFD_DELAY_VALUE : string;  
attribute IFD_DELAY_VALUE of DataIn1: label is "5";
```

Verilog Syntax

Attach a Verilog attribute to the appropriate top-level port.

```
(* IFD_DELAY_VALUE="value" *) input top_level_port_name;
```

The following statement assigns an IFD_DELAY_VALUE increment of 5 to the net **DataIn1**:

```
(* IFD_DELAY_VALUE="5" *) input DataIn1;
```

UCF and NCF Syntax

```
NET "top_level_port_name" IFD_DELAY_VALUE = value;
```

value is the numerical IBUF delay setting

The following statement assigns an IFD_DELAY_VALUE increment of 5 to the net **DataIn1**:

```
NET "DataIn1" IFD_DELAY_VALUE = 5;
```

IN_TERM (In Term)

The IN_TERM (In Term) constraint:

- Is a basic mapping constraint.
- Sets a configuration of input termination resistors .

In Term is valid on an input pad NET, input pad INST, or for the entire design.

Architecture Support

Applies to FPGA devices. Does not apply to CPLD devices.

Applicable Elements

This constraint may be used with an FPGA device in one or more of the following design elements, or categories of design elements:

- IOB input components (such as IBUF)
- Input Pad Net

Not all devices support all elements. To see which design elements can be used with which devices, see the *Libraries Guides*. For more information, see the device [data sheet](#).

Propagation Rules

IN_TERM is illegal when attached to a net or signal, except when the net or signal is connected to a pad. In this case, IN_TERM is treated as attached to the pad instance.

Syntax Examples

The following examples show how to use this constraint with particular tools or methods. If a tool or method is not listed, you cannot use this constraint with it.

Values

- NONE
- TUNED_SPLIT
- UNTUNED_SPLIT_25
- UNTUNED_SPLIT_50
- UNTUNED_SPLIT_75

Schematic Syntax

- Attach to a pad net
- Attribute Name
IN_TERM
- Attribute Values
See *Values* section above.

VHDL Syntax

Declare the VHDL constraint as follows:

Attribute IN_TERM: string;

Specify the VHDL constraint as follows:

```
attribute IN_TERM of signal_name: signal is "{NONE | TUNED_SPLIT |  
UNTUNED_SPLIT_25 | UNTUNED_SPLIT_50 | UNTUNED_SPLIT_75}";
```

For more information about basic VHDL syntax, see [VHDL Attributes](#).

Verilog Syntax

Place the Verilog constraint immediately before the module or instantiation.

Specify the Verilog constraint as follows:

```
(* IN_TERM = "{NONE | TUNED_SPLIT | UNTUNED_SPLIT_25 |  
UNTUNED_SPLIT_50 | UNTUNED_SPLIT_75 }" *)
```

For more information about basic Verilog syntax, see [Verilog Attributes](#).

UCF and NCF Syntax

The following statement configures the IO to use a PULLUP.

```
NET "pad_net_name"IN_TERM = "{NONE | TUNED_SPLIT | UNTUNED_SPLIT_25  
| UNTUNED_SPLIT_50 | UNTUNED_SPLIT_75 }";
```

The following statement configures IN_TERM to be used globally.

```
DEFAULT IN_TERM = TUNED_SPLIT;
```

XCF Syntax

```
BEGIN MODEL "entity_name"
```

```
NET "signal_name" in_term=tuned_split;
```

```
END;
```

PlanAhead Syntax

For more information about using the PlanAhead software to create constraints, see *Floorplanning the Design* in the *PlanAhead User Guide (UG632)*. See [PlanAhead](#) in this Guide for information about:

- Defining placement constraints
- Assigning placement constraints
- Defining I/O pin configurations
- Floorplanning and placement constraints

INREG (Input Registers)

INREG (Input Registers) applies to register and latch instances with their D-inputs driven by input pads, or to the Q-output nets of such registers and latches. By default, registers and latches for CoolRunner™ XPLA3 and CoolRunner-II designs that have their D-inputs driven by input pads are automatically implemented using the device's Fast Input path, where possible. If you disable the ISE® Design Suite property Use Fast Input for INREG for the Fit (Implement Design) process, then only register and latches with the INREG attribute are considered for Fast Input optimization.

Architecture Support

Applies to CoolRunner™ XPLA3 and CoolRunner-II devices only.

Applicable Elements

Applies to register and latch instances with their D-inputs driven by input pads or to the Q-output nets of such registers or latches.

Propagation Rules

Applies to register or latch to which it is attached or to the Q-output nets of such registers or latches

Syntax Examples

The following examples show how to use this constraint with particular tools or methods. If a tool or method is not listed, you cannot use this constraint with it.

Schematic Syntax

- Attach to a register, latch, or net
- Attribute Name
INREG
- Attribute Values
None (TRUE by default)

UCF Syntax

```
NET "signal_name" INREG;  
INST "register_name" INREG;
```

Internal Vref Bank (INTERNAL_VREF_BANK)

The Internal Vref Bank (INTERNAL_VREF_BANK) constraint:

- Provides a means of assigning a voltage value to the internal Vref feature for a given IO bank.
- Is useful for freeing the Vref pins of IO banks from their function of providing a voltage reference. By using the internal Vref on an IO bank, the Vref pins can assume an alternative use.

Architecture Support

Applies to Virtex®-6, Kintex™-7, and Virtex®-7 devices

Applicable Elements

This constraint is a global CONFIG constraint and is not attached to any instance or signal name.

Propagation Rules

Applies to IOs in the specified bank for the entire design

Syntax

The following sections show the syntax for this constraint.

Syntax Examples

The following examples show how to use this constraint with particular tools or methods. If a tool or method is not listed, you cannot use this constraint with it.

UCF and NCF Syntax

```
CONFIG INTERNAL_VREF_BANK $n=v$ ;
```

where

- n is the number of the bank
- v is the target voltage value (0.0, 0.6, 0.675, 0.75, 0.9, 1.1, 1.25)

Example

```
CONFIG INTERNAL_VREF_BANK5=1.1;
```

IOB (IOB)

The IOB constraint:

- Is a basic mapping and synthesis constraint.
- Indicates which flip-flops and latches can be moved into the **IOB/ILOGIC/OLOGIC**.

The mapper supports a command line option (**-pr i | o | b | off**) that allows flip-flop or latch primitives to be pushed into the input IOB (i), output IOB (o), or input/output IOB (b) on a global scale. The IOB constraint, when associated with a flip-flop or latch, tells the mapper to pack that instance into an IOB type component if possible. The IOB constraint has precedence over the mapper **-pr** command line option. However, IOB constraints do not have precedence over LOC constraints.

XST considers the IOB constraint as an implementation constraint, and therefore propagates it in the generated NGC file. XST also duplicates the flip-flops and latches driving the Enable pin of output buffers, so that the corresponding flip-flops and latches can be packed in the IOB.

- **TRUE**
Allows the flip-flop or latch to be pulled into an IOB
- **FALSE**
Indicates not to pull it into an IOB
- **AUTO**
Used by XST only. XST takes into account timing constraints and automatically decides to push or not to push flip-flops into IOBs
- **FORCE**
Requires that the flip-flop or latch be pulled into an IOB, otherwise an error is given. **FORCE** produces an error only if the register has I/O connections and cannot be packed in the IOB.

Architecture Support

Applies to FPGA devices. Does not apply to CPLD devices.

Applicable Elements

- Non-INFF/OUTFF flip-flop and latch primitives
- Registers

Propagation Rules

Applies to the design element to which it is attached.

Syntax Examples

The following examples show how to use this constraint with particular tools or methods. If a tool or method is not listed, you cannot use this constraint with it.

Schematic Syntax

- Attach to a flip-flop or latch instance or to a register
- Attribute Name

IOB

VHDL Syntax

Declare the VHDL constraint as follows:

```
attribute iob: string;
```

Specify the VHDL constraint as follows:

```
attribute iob of {component_name | entity_name | label_name | signal_name} :  
{component | entity | label | signal} is "{TRUE|FALSE|AUTO|FORCE}";
```

For more information about basic VHDL syntax, see [VHDL Attributes](#).

Verilog Syntax

Place the Verilog constraint immediately before the module or instantiation.

Specify the Verilog constraint as follows:

```
(* IOB = "{TRUE|FALSE |AUTO|FORCE}" *)
```

For more information about basic Verilog syntax, see [Verilog Attributes](#).

UCF and NCF Syntax

```
INST "instance_name" IOB={TRUE|FALSE|FORCE};
```

The following statement instructs the mapper to place the **foo/bar** instance into an IOB component.

```
INST "foo/bar" IOB=TRUE;
```

Note The NET "**foo/bar**" IOB=TRUE; syntax is not supported in the User Constraints File (UCF). The supported syntax is INST "**foo/bar**" IOB=TRUE;

XCF Syntax

```
BEGIN MODEL "entity_name"
```

```
NET "signal_name" iob={true | false | auto | force};
```

```
INST " instance_name" iob={true | false | auto | force};
```

```
END;
```

For the **AUTO** option, XST takes into account timing constraints and automatically decides to push or not to push flip-flops into IOBs

Constraints Editor Syntax

For information on setting constraints in Constraints Editor, including syntax, see the Constraints Editor Help.

IOBDELAY (Input Output Block Delay)

The IOBDELAY (Input Output Block Delay) constraint:

- Is a basic mapping constraint.
- Specifies how the input path delay elements in all devices are to be programmed.

There are two possible destinations for input signals:

- The local IOB input FF
- A load external to the IOB

Xilinx® devices allow a delay element to delay the signal going to one or both of these destinations.

IOBDELAY cannot be used concurrently with [No Delay \(NODELAY\)](#).

- **NONE** sets the delay **OFF** for both the **IBUF** and **IFD** paths.
 - The following statement sets the delay **OFF** for the **IBUF** and **IFD** paths.
`INST "xyzyz" IOBDELAY=NONE`
 - For Spartan®-3 devices, the default is not set to **NONE** so the device can achieve a zero hold time.
- **BOTH** sets the delay **ON** for both the **IBUF** and **IFD** paths.
- **IBUF** sets the delay to **OFF** for any register inside the I/O component and to **ON** for the registers outside of the component if the input buffer drives a register D pin outside of the I/O component.
- **IFD** sets the delay to **ON** for any register inside the I/O component and to **OFF** for the registers outside the component if a register occupies the input side of the I/O component, regardless of whether the register has the **IOB=TRUE** constraint.

Architecture Support

Applies to FPGA devices. Does not apply to CPLD devices.

Applicable Elements

Any I/O symbol (I/O pads, I/O buffers, or input pad nets)

Propagation Rules

Although IOBDELAY is attached to an I/O symbol, it applies to the entire I/O component.

Syntax Examples

The following examples show how to use this constraint with particular tools or methods. If a tool or method is not listed, you cannot use this constraint with it.

Schematic Syntax

- Attach to an I/O symbol
- Attribute Name: **IOBDELAY**

VHDL Syntax

Declare the VHDL constraint as follows:

```
attribute iobdelay: string;
```

Specify the VHDL constraint as follows:

```
attribute iobdelay of {component_name | label_name}: {component|label} is  
“{NONE|BOTH|IBUF|IFD}”;
```

For more information about basic VHDL syntax, see [VHDL Attributes](#).

Verilog Syntax

Place the Verilog constraint immediately before the module or instantiation.

Specify the Verilog constraint as follows:

```
(* IOBDELAY = {NONE|BOTH|IBUF|IFD} *)
```

For more information on basic Verilog syntax, see [Verilog Attributes](#).

UCF and NCF Syntax

```
INST “instance_name” IOBDELAY={NONE|BOTH|IBUF|IFD};
```

IODELAY_GROUP (IODELAY Group)

The IODELAY_GROUP (IODELAY Group) constraint:

- Is a design implementation constraint.
- Groups a set of IDELAY and IODELAY constraints with an IDELAYCTRL to enable automatic replication and placement of IDELAYCTRL in a design.

For more information, see the IDELAYCTRL section of the appropriate device user guide.

Limitations with LOC

- Use IODELAY_GROUP only when replicating a single IDELAYCTRL to multiple banks, without a LOC constraint.
- Do not use IODELAY_GROUP in conjunction with IDELAYCTRL instances that have a LOC constraint.
- Instantiate only one IDELAYCTRL in the design.
- Do not apply a LOC constraint.
- Group any IODELAY constraint that needs an IDELAYCTRL into an IODELAY_GROUP.
- Create one group for each bank.

Architecture Support

Applies to Virtex®-4, Virtex-5, Virtex-6, and 7 series devices.

- For Virtex-4 devices, IODELAY_GROUP is supported only when using the Timing Driven Pack and Placement Option in MAP.
- While IODELAY_GROUP is supported on Virtex-4 and Virtex-5 devices, it is not the recommended method for replicating IDELAYCTRL. For the recommended method, see the appropriate device user guide.
- IODELAY_GROUP is the recommended method for replicating IDELAYCTRL primitives on Virtex-6 and 7 series devices.

Applicable Elements

IDELAY, IODELAY, IODELAYE1, IDELAYE2, ODELAYE2 and IDELAYCTRL

Propagation Rules

IODELAY_GROUP can only be attached to a design element. It is illegal to attach IODELAY_GROUP to a net, signal, or pin. To merge two or more embedded IODELAY_GROUP constraints in your design, see [MIODELAY_GROUP](#).

Syntax Examples

The following examples show how to use this constraint with particular tools or methods. If a tool or method is not listed, you cannot use this constraint with it.

VHDL Syntax

Declare the VHDL constraint as follows:

```
attribute IODELAY_GROUP: string;
```

Specify the VHDL constraint as follows:

```
attribute IODELAY_GROUP of {component_name|label_name}: {component|label} is  
"group_name";
```

For a description of *group_name*, see the UCF Syntax for this constraint.

For more information about basic VHDL syntax, see [VHDL Attributes](#).

Verilog Syntax

Place the Verilog constraint immediately before the module or instantiation.

Specify the Verilog constraint as follows:

```
(* IODELAY_GROUP = "group_name" *)
```

For a description of *group_name*, see *UCF Syntax* below.

For more information about basic Verilog syntax, see [Verilog Attributes](#).

UCF Syntax

```
INST "instance_name" IODELAY_GROUP = group_name;
```

where

group_name is the name assigned to a set of IDELAY or IODELAY constraints and an IDELAYCTRL to uniquely define the group.

IOSTANDARD (Input Output Standard)

The IOSTANDARD (Input Output Standard) constraint:

- Is a basic mapping constraint.
- Is a synthesis constraint.

IOSTANDARD for FPGA Devices

Use IOSTANDARD to assign an I/O standard to an I/O primitive.

All components with IOSTANDARD must follow the same placement rules (banking rules) as the SelectIO™ components. See the Xilinx® *Libraries Guides* for information on the banking rules for each architecture. For descriptions of the supported I/O standards, see the device [data sheet](#).

For Spartan®-3, Spartan-3A, Spartan-3E, Virtex®-4, and Virtex-5 devices, the recommended procedure is to attach IOSTANDARD to a buffer component instead of using the SelectIO variants of a component. For example, use an IBUF with the IOSTANDARD=HSTL_III constraint instead of the IBUF_HSTL_III component.

For Spartan-3, Spartan-3A, Spartan-3E, Virtex-4, and Virtex-5 devices, differential signaling standards apply to IBUFDS, IBUFGDS, OBUFDS, and OBUFTDS only (not IBUF or OBUF).

IOSTANDARD for CPLD Devices

You can apply IOSTANDARD to I/O pads of CoolRunner™-II devices to specify both input threshold and output VCCIO voltage. For supported values, see the device [data sheet](#).

The CPLD fitter automatically groups outputs with compatible IOSTANDARD settings into the same bank when no location constraints are specified.

Architecture Support

Applies to all FPGA devices and CoolRunner-II CPLD devices.

Applicable Elements

To see which design elements can be used with which device families, see the *Libraries Guides*. For more information, see the device [data sheet](#).

- IBUF, IBUFG, OBUF, OBUFT
- IBUFDS, IBUFGDS, OBUFDS, OBUFTDS
- Output Voltage Banks

Propagation Rules

It is illegal to attach IOSTANDARD to a net or signal except when the signal or net is connected to a pad. In this case, IOSTANDARD is treated as attached to an IOB instance (IBUF, OBUF, IOB FF). When attached to a design element, IOSTANDARD propagates to all applicable elements in the hierarchy within the design element.

Syntax Examples

The following examples show how to use this constraint with particular tools or methods. If a tool or method is not listed, you cannot use this constraint with it.

Schematic Syntax

- Attach to an I/O primitive
- Attribute Name

IOSTANDARD

- Attribute Values
- iostandard_name**

For more information, see *UCF and NCF Syntax* below.

VHDL Syntax

Declare the VHDL constraint as follows:

attribute iostandard: string;

Specify the VHDL constraint as follows:

attribute iostandard of {*component_name*|*label_name*}: {**component**|**label**} **is**
"iostandard_name";

For more information, see *UCF and NCF Syntax* below.

For CPLD devices you can also apply IOSTANDARD to the pad signal.

For more information about basic VHDL syntax, see [VHDL Attributes](#).

Verilog Syntax

Place the Verilog constraint immediately before the module or instantiation.

Specify the Verilog constraint as follows:

For a description of *iostandard_name*, see the UCF section.

For CPLD devices you can also apply IOSTANDARD to the pad signal.

For more information about basic Verilog syntax, see [Verilog Attributes](#).

UCF and NCF Syntax

INST "*instance_name*" **IOSTANDARD=** *iostandard_name*;

NET "*pad_net_name*" **IOSTANDARD=***iostandard_name*;

iostandard_name is an IO Standard name as specified in the device [data sheet](#).

XCF Syntax

BEGIN MODEL "*entity_name*"

INST "*instance_name*" **iostandard=***string* ;

NET "*signal_name*" **iostandard=***string* ;

END;

PlanAhead Syntax

For more information about using the PlanAhead software to create constraints, see *Floorplanning the Design* in the *PlanAhead User Guide (UG632)*. See [PlanAhead](#) in this Guide for information about:

- Defining placement constraints
- Assigning placement constraints
- Defining I/O pin configurations
- Floorplanning and placement constraints

Pinout and Area Constraints Editor (PACE) Syntax

Pinout and Area Constraints Editor (PACE) is supported for CPLD devices only. PACE is NOT supported for FPGA devices.

Access PACE from **ISE® Design Suite > Processes**.

Use PACE to:

- Assign location constraints to IOs
- Assign certain IO properties such as IO Standards

For more information, see the PACE Help, especially the topics in **Procedures > Editing Pins and Areas**.

KEEP (Keep)

The KEEP (Keep) constraint:

- Is an advanced mapping constraint.
- Is a synthesis constraint.

When a design is mapped, some nets may be absorbed into logic blocks. When a net is absorbed into a block, it can no longer be seen in the physical design database. This may happen, for example, if the components connected to each side of a net are mapped into the same logic block. The net may then be absorbed into the block containing the components. KEEP prevents this from happening.

KEEP is translated into an internal constraint known as **NOMERGE** when targeting an FPGA. Messaging from the implementation tools therefore refers to the system property **NOMERGE**, not KEEP. In addition to **TRUE** and **FALSE**, synthesis (XST) accepts and additional **SOFT** value that instructs the tool to preserve the designated net, but also prevents it from attaching a **NOMERGE** constraint to this net in the synthesized netlist. As a result, the net is preserved during synthesis, but implementation tools are given all freedom to handle it. Conceptually, you are specifying a **KEEP=TRUE** for synthesis only, but a **KEEP=FALSE** for implementation tools.

Architecture Support

Applies to all FPGA devices and all CPLD devices.

Applicable Elements

Applies to signals.

Propagation Rules

Applies to the signal to which it is attached.

Syntax Examples

The following examples show how to use this constraint with particular tools or methods. If a tool or method is not listed, you cannot use this constraint with it.

Schematic Syntax

- Attach to a net
- Attribute Name
KEEP
- Attribute Values
TRUE
FALSE
SOFT (XST only)

VHDL Syntax

Declare the VHDL constraint as follows:

```
attribute keep : string;
```

Specify the VHDL constraint as follows:

```
attribute keep of signal_name: signal is "{TRUE|FALSE|SOFT}";
```

For more information about basic VHDL syntax, see [VHDL Attributes](#).

Verilog Syntax

Place the Verilog constraint immediately before the module or instantiation.

Specify the Verilog constraint as follows:

```
(* KEEP = "{TRUE|FALSE|SOFT}" *)
```

For more information about basic Verilog syntax, see [Verilog Attributes](#).

UCF and NCF Syntax

```
INST "instance_name" KEEP={TRUE|FALSE};
```

The following statement ensures that the net \$SIG_0 remains visible.

```
NET "$1I3245/$SIG_0" KEEP;
```

XCF Syntax

```
BEGIN MODEL "entity_name"
```

```
NET "signal_name" keep={yes|no|true|false};
```

```
END;
```

In an XST Constraint File (XCF) file, the value of the **KEEP** constraint may optionally be enclosed in double quotes. For the **SOFT** value, this becomes mandatory, as shown below:

```
BEGIN MODEL "entity_name"
```

```
NET "signal_name" keep="soft";
```

```
END;
```

KEEP_HIERARCHY (Keep Hierarchy)

KEEP_HIERARCHY (Keep Hierarchy) is a synthesis and implementation constraint. If hierarchy is maintained during synthesis, the implementation software uses KEEP_HIERARCHY to preserve the hierarchy throughout the implementation process and allow a simulation netlist to be created with the desired hierarchy.

XST may flatten the design to get better results by optimizing entity or module boundaries. You can set KEEP_HIERARCHY to **true** so that the generated netlist is hierarchical and respects the hierarchy and interface of any entity or module of your design.

This option is related to the hierarchical blocks (VHDL entities, Verilog modules) specified in the Hardware Description Language (HDL) design and does not concern the macros inferred by the HDL synthesizer. Three values are available for this option:

- **true**
Allows the preservation of the design hierarchy, as described in the HDL project. If this value is applied to synthesis, it is also propagated to implementation.
- **false**
Hierarchical blocks are merged in the top level module.
- **soft**
Allows the preservation of the design hierarchy in synthesis, but the KEEP_HIERARCHY constraint is not propagated to implementation.

For CPLD devices, the default is **true**. For FPGA devices, the default is **false**

Note In XST, the KEEP_HIERARCHY constraint can be set to the following values: **yes**, **true**, **no**, **false**, and **soft**. When used at the command line, only **yes**, **no**, and **soft** are accepted.

In general, an HDL design is a collection of hierarchical blocks. Preserving the hierarchy gives the advantage of fast processing because the optimization is done on separate pieces of reduced complexity. Nevertheless, very often, merging the hierarchy blocks improves the fitting results (fewer PTerms and device macrocells, better frequency) because the optimization processes (collapsing, factorization) are applied globally on the entire logic.

KEEP_HIERARCHY enables or disables hierarchical flattening of user-defined design units. Allowed values are **true** and **false**. By default, the user hierarchy is preserved.

In the following figure, if KEEP_HIERARCHY is set to the entity or module I2, the hierarchy of I2 is in the final netlist, but its contents I4, I5 are flattened inside I2. Also I1, I3, I6, I7 are flattened.

KEEP_HIERARCHY EXAMPLE

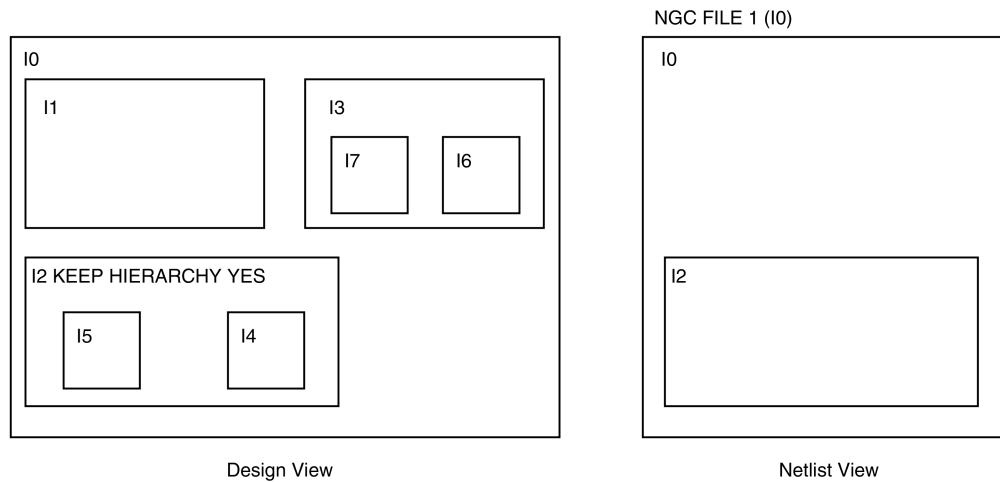

X9542

Architecture Support

Applies to all FPGA devices and all CPLD devices.

Applicable Elements

Attached to logical blocks, including blocks of hierarchy or symbols.

Propagation Rules

Applies to the entity, module, or signal to which it is attached.

Syntax

The following examples show how to use this constraint with particular tools or methods. If a tool or method is not listed, you cannot use this constraint with it.

Schematic Syntax

- Attach to the entity or module symbol
- Attribute Name
KEEP_HIERARCHY
- Attribute Values
 - TRUE
 - FALSE

VHDL Syntax

Declare the VHDL constraint as follows:

```
attribute keep_hierarchy : string;
```

Specify the VHDL constraint as follows:

```
attribute keep_hierarchy of architecture_name: architecture is {TRUE|FALSE|SOFT};
```

The default is **false** for FPGA devices and **true** for CPLD devices.

For more information about basic VHDL syntax, see [VHDL Attributes](#).

Verilog Syntax

Place the Verilog constraint immediately before the module or instantiation.

Specify the Verilog constraint as follows:

```
(* KEEP_HIERARCHY = "{TRUE|FALSE}" *)
```

For more information about basic Verilog syntax, see [Verilog Attributes](#).

UCF and NCF Syntax

```
INST "instance_name" KEEP_HIERARCHY={TRUE|FALSE};
```

XCF Syntax

In XST, KEEP_HIERARCHY accepts the following values:

- **yes**
- **true**
- **no**
- **false**
- **soft**

When KEEP_HIERARCHY is used as a command-line switch, only **yes**, **no**, and **soft** are accepted.

```
MODEL "entity_name" keep_hierarchy={yes|no|soft};
```

ISE Design Suite Syntax

Define globally with ISE® Design Suite > Process > Properties > Synthesis Options > **Keep Hierarchy**. With a design selected in the Sources window, select **Processes > Synthesize > Process Properties > Property display level > Advanced**.

Keeper (KEEPER)

The Keeper (KEEPER) constraint:

- Is a basic mapping constraint.
- Retains the value of the output net to which it is attached.

For example, if logic 1 is being driven onto the net, KEEPER drives a weak/resistive 1 onto the net. If the net driver is then tristated, KEEPER continues to drive a weak/resistive 1 onto the net.

The KEEPER constraint must follow the same banking rules as the KEEPER component. For more information on banking rules, see the Xilinx® *Libraries Guides*.

KEEPER, PULLUP, and PULLDOWN are valid only on pad NETs, not on INSTs of any kind.

For CoolRunner™-II devices, the use of KEEPER and the use of PULLUP are mutually exclusive across the whole device.

Architecture Support

Applies to all FPGA devices and CoolRunner-II CPLD devices.

Applicable Elements

Tristate input/output pad nets

Propagation Rules

KEEPER is illegal when attached to a net or signal except when the net or signal is connected to a pad. In this case, KEEPER is treated as attached to the pad instance.

Syntax Examples

The following examples show how to use this constraint with particular tools or methods. If a tool or method is not listed, you cannot use this constraint with it.

Schematic Syntax

- Attach to an output pad net
- Attribute Name
KEEPER
- Attribute Values
 - TRUE
 - FALSE

VHDL Syntax

Declare the VHDL constraint as follows:

```
attribute keeper: string;
```

Specify the VHDL constraint as follows:

```
attribute keeper of signal_name : signal is "{YES|NO|TRUE|FALSE}";
```

For more information about basic VHDL syntax, see [VHDL Attributes](#).

Verilog Syntax

Place the Verilog constraint immediately before the module or instantiation.

Specify the Verilog constraint as follows:

```
(* KEEPER = " {YES|NO|TRUE|FALSE}" *)
```

For more information about basic Verilog syntax, see [Verilog Attributes](#).

UCF and NCF Syntax

This statement configures the IO to use KEEPER for a NET.

```
NET "pad_net_name" KEEPER;
```

This statement configures KEEPER to be used globally.

```
DEFAULT KEEPER = TRUE;
```

XCF Syntax

```
BEGIN MODEL "entity_name"
```

```
NET "signal_name" keeper={yes|no|true |false};
```

```
END;
```

LOC (Location)

The LOC (Location) constraint:

- Is a basic placement constraint.
- Is a synthesis constraint.

LOC Description for FPGA Devices

LOC defines where a design element can be placed within an FPGA device. LOC specifies the absolute placement of a design element on the FPGA die. It can be a single location, a range of locations, or a list of locations. You can specify LOC from the design file and also direct placement with statements in a constraints file.

To specify multiple locations for the same symbol, separate each location in the field with a comma. The comma specifies that the symbols can be placed in any of the specified locations. You can also specify an area in which to place a design element or group of design elements.

A convenient way to find legal site names is to use the PlanAhead™ software or FPGA Editor. The legal names are a function of the target part type. To find the correct syntax for specifying a target location, load an empty part into FPGA Editor, Place the cursor on any block, then click the block to display its location in the FPGA Editor history area. Do not include the pin name such as .I, .O, or .T as part of the location.

You can use LOC for logic that uses multiple CLBs, IOBs, soft macros, or other symbols. To do this, use LOC on a soft macro symbol, which passes the location information down to the logic on the lower level. The location restrictions are automatically applied to all blocks on the lower level for which LOCs are legal.

FPGA devices use a Cartesian-based XY designator at the slice level. The slice-based location specification uses the form:

SLICE_XmYn.

The XY slice grid starts as X0Y0 in the lower left CLB tile of the chip. The X values start at 0 and increase horizontally to the right in the CLB row, with two different X values per CLB. The Y values start at 0 and increase vertically up in the CLB column, with two different Y values per CLB.

Following are examples of how to specify the slices in the XY coordinate system.

Single LOC Constraint Examples

SLICE_X0Y0	First (bottom) slice of the CLB in the lower left corner of the chip
SLICE_X0Y1	Second slice of the CLB in the lower left corner of the chip
SLICE_X1Y0	Third slice of the CLB in the lower left corner of the chip
SLICE_X1Y1	Fourth (top) slice of the CLB in the lower left corner of the chip
SLICE_X0Y2	First slice of the second CLB in CLB column 1
SLICE_X2Y0	First (bottom) slice of the bottom CLB in CLB column 2
SLICE_X2Y1	Second slice of the bottom CLB in CLB column 2
SLICE_X50Y125	Slice located 125 slices up from and 50 slices to the right of SLICE_X0Y0

FPGA block RAMs and multipliers have their own specification different from the SLICE specifications. Therefore, the location value must start with **SLICE**, **RAMB**, or **MULT**.

- A block RAM located at **RAMB16_X2Y3** is not located at the same site as a flip-flop located at **SLICE_X2Y3**.
- A multiplier located at **MULT18X18_X2Y3** is not located at the same site as a flip-flop located at **SLICE_X2Y3** or at the same site as a block RAM located at **RAMB16_X2Y3**.

The location values for global buffers (BUFGs) and DCM elements is the specific physical site names for available locations.

Pin assignment using LOC is not supported for bus pad symbols such as OPAD8.

Location Specification Types for FPGA Devices

Element Types	Location Examples	Meaning
IOBs	P12	IOB location (chip carrier)
	A12	IOB location (pin grid)
	B, L, T, R	Applies to IOBs and indicates edge locations (bottom, left, top, right) for the following devices: Spartan®-3, Spartan-3A, Spartan-3E
	LB, RB, LT, RT, BR, TR, BL, TL	Applies to IOBs and indicates half edges (for example, left bottom, right bottom) for the following devices: Spartan-3, Spartan-3A, Spartan-3E
	Bank#	Applies to IOBs and indicates the bank for all FPGA devices
Slices	SLICE_X2Y3	SLICE_X2Y3 Slice location for all FPGA devices
Block RAMs	RAMB16_X2Y56	Block RAM location for the following devices: Spartan®-3, Spartan-3A, Spartan-3Es
	RAMB36_X2Y56	Block RAM location for Virtex®-5 devices
Multipliers	MULT18X18_X#Y#	Multiplier location for Spartan-3 and Spartan-3A devices
	DSP48_X#Y#	Multiplier location for Virtex-4 and Virtex-5 devices
Digital Clock Manager	DCM_X#Y#	Digital Clock Manager for the following devices: Spartan-3, Spartan-3A, Spartan-3E
	DCM_ADV_X#Y#	Digital Clock Manager for Virtex-4 and Virtex-5 devices
Phase Lock Loop	PLL_ADV_X#Y#	Phase Lock Loop for all FPGA devices

The wildcard character (*) can be used to replace a single location with a range as shown in the following example:

SLICE_X*Y5	Any slice of a FPGA device whose Y coordinate is 5
------------	--

The wildcard character for an FPGA global buffer, global pad, or DCM locations, is *not* supported.

LOC Description for CPLD Devices

For CPLD devices, use the `LOC=pin_name` constraint on a PAD symbol or pad net to assign the signal to a specific pin. The PAD symbols are IPAD, OPAD, IOPAD, and UPAD. You can use the `LOC=FBnn` constraint on any instance or its output net to assign the logic or register to a specific function block or macrocell, provided the instance is not collapsed.

The `LOC=FB nn_mm` constraint on any internal instance or output pad assigns the corresponding logic to a specific function block or macrocell within the CPLD. If a LOC is placed on a symbol that does not get mapped to a macrocell or is otherwise removed through optimization, the LOC is ignored.

LOC Priority

When specifying two adjacent LOC constraints on an input pad and its adjoining net, the LOC attached to the net has priority. In the following diagram, `LOC=11` takes priority over `LOC=38`.

LOC Priority Example

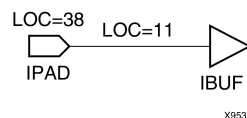

Architecture Support

Applies to all FPGA devices and all CPLD devices.

Applicable Elements

For information about which design elements can be used with which device families, see the *Libraries Guides*. For more information, see the device data sheet.

Propagation Rules

For all nets, LOC is illegal when attached to a net or signal except when the net or signal is connected to a pad. In this case, LOC is treated as attached to the pad instance.

For CPLD nets, LOC attaches to all applicable elements that drive the net or signal.

When attached to a design element, LOC propagates to all applicable elements in the hierarchy within the design element.

Constraint Syntax

Following is the syntax for a single location:

```
INST "instance_name" LOC=location;
```

where

location is a legal location for the part type

Syntax Examples for Single LOC Constraints

Constraint (UCF Syntax)		Description
INST "instance_name" LOC=P12;		Place I/O at location P12.
INST "instance_name " LOC=SLICE_X3Y2;	Spartan-3, Spartan-3A, Spartan-3E, Virtex-4, and Virtex-5	Place logic in slice X3Y2 on the XY SLICE grid.
INST "instance_name " LOC=RAMB16_X0Y6;	Spartan-3, Spartan-3A, Spartan-3E, and Virtex-4	Place the logic in the block RAM located at RAMB16_X0Y6 on the XY RAMB grid.
INST "instance_name " LOC=MULT18X18_X0Y6;	Spartan-3 and Spartan-3A	Place the logic in the multiplier located at MULT18X18_X0Y6 on the XY MULT grid.
INST "instance_name " LOC=FIFO16_X0Y15;	Virtex-4	Place the logic in the FIFO located at FIFO16_X0Y15 on the XY FIFO grid.
INST "instance_name " LOC=IDELAYCTRL_X0Y3;	Virtex-4 and Virtex-5	Place the logic in the IDELAYCTRL located at the IDELAYCTRL_X0Y3 on the XY IDELAYCTRL grid.

Following is the syntax for multiple locations:

LOC= *location1,location2 ,...,locationx*

Separating each such constraint by a comma specifies multiple locations for an element. When you specify multiple locations, PAR can use any of the specified locations. Examples of multiple LOC constraints are provided in the following table.

Multiple LOC Constraint Examples

Constraint		Description
INST "instance_name " LOC=SLICE_X2Y10, SLICE_X1Y10;	FPGA	Place the logic in SLICE_X2Y10 or in SLICE_X1Y10 on the XY SLICE grid.

Currently, using a single constraint there is no way to constrain multiple elements to a single location or multiple elements to multiple locations.

Following is the syntax for a range of locations:

INST " instance_name" LOC=location :location {SOFT };

You can define a range by specifying the two corners of a bounding box. Except for Spartan-3, Spartan-3A, Spartan-3E, Virtex-4, and Virtex-5 devices, specify the upper left and lower right corners of an area in which logic is to be placed. For FPGA devices, specify the lower left and upper right corners. Use a colon (:) to separate the two boundaries.

The logic represented by the symbol is placed somewhere inside the bounding box. The default is to interpret the constraint as a "hard" requirement and to place it within the box. If SOFT is specified, PAR may place the constraint elsewhere if better results can be obtained at a location outside the bounding box. Examples of LOC constraints used to specify a range are given in the following table.

LOC Range Constraint Examples

Constraint		Description
<pre>INST "instance_name" LOC=SLICE_X3Y5:SLICE_X5Y20;</pre>	FPGA	Place logic in any slice within the rectangular area bounded by SLICE_X3Y5 (the lower left corner) and SLICE_X5Y20 (the upper right corner) on the XY SLICE grid.

LOC ranges can be supplemented with the keyword SOFT. Unlike AREA_GROUP, LOC ranges do not influence the packing of symbols. LOC range is strictly a placement constraint used by PAR.

Following is the LOC syntax for CPLD devices:

```
INST "instance_name" LOC=pin_name;
```

or

```
INST "instance_name" LOC=FBff;
```

or

```
INST "instance_name" LOC=FB ff_mm;
```

where

- *pin_name* is *Pnn* for numeric pin names or *rc* for row-column pin names
- *ff* is a function block number
- *mm* is a macrocell number within a function block

The two constraint formats for **FBff** and **FBff_mm** are only applicable for outputs and bidirectional pins, not for inputs.

The first constraint format:

```
INST "instance_name" LOC=pin_name;
```

is applicable for all types of IO.

Syntax Examples

For examples of legal placement constraints for each type of logic element in FPGA designs, see Syntax for FPGA Devices for this constraint, and the [Relative Location \(RLOC\)](#) constraint. Logic elements include flip-flops, ROMs and RAMs, block RAMS, FMAPs, BUFTs, CLBs, IOBs, I/Os, edge decoders, and global buffers.

The following examples show how to use this constraint with particular tools or methods. If a tool or method is not listed, you cannot use this constraint with it.

Schematic Syntax

- Attach to an instance
- Attribute Name: **LOC**
- Attribute Values: **value**

For valid values, see Syntax for FPGA Devices and Syntax for CPLD Devices for this constraint.

VHDL Syntax

Declare the VHDL constraint as follows:

```
attribute loc: string;
```

Specify the VHDL constraint as follows:

attribute loc of {*signal_name* | *label_name*}: {**signal** | **label**} **is** "*location*";

Set the LOC constraint on a bus as follows:

attribute loc of *bus_name* : **signal is** "*location_1 location_2 location_3...*";

To constrain only a portion of a bus (CPLD devices only), use the following syntax:

attribute loc of *bus_name* : **signal is** "*** * location_1 * location_2...*";

For more information about *location*, see Syntax for FPGA Devices and Syntax for CPLD Devices for this constraint.

For more information about basic VHDL syntax, see [VHDL Attributes](#).

Verilog Syntax

Place the Verilog constraint immediately before the module or instantiation.

Specify the Verilog constraint as follows:

(* LOC = "*location*" *)

Set the LOC constraint on a bus as follows:

(* LOC = "*location_1 location_2 location_3...* " *)

To constrain only a portion of a bus (CPLD devices only), use the following syntax:

(* LOC = "*** * location_1 location_2...*" *)

For more information about *location*, see Syntax for FPGA Devices and Syntax for CPLD Devices for this constraint.

For more information about basic Verilog syntax, see [Verilog Attributes](#).

UCF and NCF Syntax

The following statement specifies that each instance found under "FLIP_FLOPS" is to be placed in any CLB in column 8.

INST "/FLIP_FLOPS/*" LOC=SLICE_X*Y8;

The following statement specifies that an instantiation of MUXBUF_D0_OUT be placed in IOB location P110.

INST "MUXBUF_D0_OUT" LOC=P110;

The following statement specifies that the net DATA<1> be connected to the pad from IOB location P111.

NET "DATA<1>" LOC=P111;

XCF Syntax

BEGIN MODEL "*entity_name*"

PIN "*signal_name*" loc=*string* ;

INST "*instance_name*" loc=*string* ;

END;

PCF Syntax

LOC writes out a LOCATE constraint to the PCF file. For more information, see the [Locate \(LOCATE\)](#) constraint.

PlanAhead Syntax

For more information about using the PlanAhead software to create constraints, see *Floorplanning the Design* in the *PlanAhead User Guide (UG632)*. See [PlanAhead](#) in this Guide for information about:

- Defining placement constraints
- Assigning placement constraints
- Defining I/O pin configurations
- Floorplanning and placement constraints

PACE Syntax

PACE is mainly used to assign location constraints to IOs. It can also be used to assign certain IO properties such as IO Standards. You can access PACE from the Processes window in the Project Navigator.

For more information, see the PACE help, especially the topics within Editing Pins and Areas in the Procedures section. PACE is supported for CPLD devices only. It is not supported for FPGA devices.

Digital Clock Manager (DCM) Constraint Examples

This section applies to all FPGA devices.

You can lock the DCM in the UCF file. The syntax is as follows:

```
INST "instance_name" LOC = DCM_XYB; (for all Spartan devices)
```

```
INST "instance_name" LOC = DCM_ADV_XYB; (for Virtex-4 and Virtex-5 devices)
```

A is the X coordinate, starting with 0 at the left-hand bottom corner. *A* increases in value as you move across the device to the right.

B is the Y coordinate, starting with 0 at the left-hand bottom corner. *B* increases in value as you move up the device.

Example

```
INST "myinstance" LOC = DCM_X0Y0;
```

Flip-Flop Constraint Examples

Flip-flop constraints can be assigned from the schematic or through the UCF file.

From the schematic, attach LOC constraints to the target flip-flop. The constraints are then passed into the EDIF netlist and are read by PAR after the design is mapped.

The following examples show how the LOC constraint is applied to a schematic and to a UCF (User Constraints File). The instance names of two flip-flops, /top-12/fdrd and /top-54/fdsd, are used to show how you would enter the constraints in the UCF.

Slice-Based XY Grid Designations

Spartan-3 devices and higher and Virtex-4 devices and higher are the only architectures that use slice-based XY grid designations.

Flip-flops can be constrained to a specific slice, a range of slices, a row or column of slices.

Example One

Place the flip-flop in SLICE_X1Y5. SLICE_X0Y0 is in the lower left corner of the device.

Schematic	LOC=SLICE_X1Y5
UCF	INST "/top-12/fdrd" LOC=SLICE_X1Y5;

Example Two

Place the flip-flop in the rectangular area bounded by the SLICE_X1Y1 in the lower left corner and SLICE_X5Y7 in the upper right corner.

Schematic	LOC=SLICE_R1C1:SLICE_R5C7
UCF	INST "/top-12/fdrd" LOC=SLICE_X1Y1:SLICE_X5Y7;

Example Three

Place the flip-flops anywhere in the row of slices whose Y coordinate is 3. Use the wildcard (*) character in place of either the X or Y value to specify an entire row (Y*) or column (X*) of slices.

Schematic	LOC=SLICE_X*Y3
UCF	INST "/top-12/fdrd/top-54/fdsd" LOC=SLICE_X*Y3;

Example Four

Place the flip-flop in either SLICE_X2Y4 or SLICE_X7Y9.

Schematic	LOC=SLICE_X2Y4,SLICE_X7Y9
UCF	INST "/top-54/fdsd" LOC=SLICE_X2Y4, SLICE_X7Y9;

In Example Four, repeating the LOC constraint and separating each such constraint by a comma specifies multiple locations for an element. When you specify multiple locations, PAR can use any of the specified locations.

Example Five

Do not place the flip-flop in the column of slices whose X coordinate is 5. Use the wildcard (*) character in place of either the X or Y value to specify an entire row (Y*) or column (X*) of slices.

Schematic	PROHIBIT=SLICE_X5Y*
UCF	CONFIG PROHIBIT=SLICE_X5Y*;

I/O Constraint Examples

You can constrain I/Os to a specific IOB. You can assign I/O constraints from the schematic or through the UCF file.

From the schematic, attach LOC constraints to the target PAD symbol. The constraints are then passed into the netlist file and read by PAR after mapping.

Alternatively, in the UCF file a pad is identified by a unique instance name. The following example shows how the LOC constraint is applied to a schematic and to a UCF (User Constraints File). In the examples, the instance names of the I/Os are /top-102/data0_pad and /top-117/q13_pad. The example uses a pin number to lock to one pin.

Schematic	LOC=P17
UCF	INST "/top-102/data0_pad" LOC=P17;

Place the I/O in the IOB at pin 17. For pin grid arrays, a pin name such as B3 or T1 is used.

IOB Constraint Examples

You can assign I/O pads, buffers, and registers to an individual IOB location. IOB locations are identified by the corresponding package pin designation.

The following examples illustrate the format of IOB constraints. Specify LOC= and the pin location. If the target symbol represents a soft macro containing only I/O elements, for example, INFF8, the LOC constraint is applied to all I/O elements contained in that macro. If the indicated I/O elements do not fit into the specified locations, an error is generated.

The following UCF statement places the I/O element in location P13. For PGA packages, the letter-number designation is used, for example, B3.

INST "instance_name" LOC=P13;

You can prohibit the mapper from using a specific IOB. You might take this step to keep user I/O signals away from semi-dedicated configuration pins. Such PROHIBIT constraints can be assigned only through the UCF file.

IOBs are prohibited by specifying a PROHIBIT constraint preceded by the CONFIG keyword, as shown in the following example.

Schematic	None
UCF	CONFIG PROHIBIT=p36, p37, p41;

Do not place user I/Os in the IOBs at pins 36, 37, or 41. For pin grid arrays, pin names such as D14, C16, or H15 are used.

Mapping Constraint Examples (FMAP)

Mapping constraints control the mapping of logic into CLBs. They have two parts. The first part is an FMAP component placed on the schematic. The second is a LOC constraint that can be placed on the schematic or in the constraints file.

FMAP controls the mapping of logic into function generators. This symbol does not define logic on the schematic; instead, it specifies how portions of logic shown elsewhere on the schematic should be mapped into a function generator.

The FMAP symbol defines mapping into a four-input (F) function generator.

For the FMAP symbol as with the CLBMAP primitive, MAP=PUC or PUO is supported, as well as the LOC constraint. (Currently, pin locking is not supported. MAP=PLC or PLO is translated into PUC and PUO, respectively.)

Example One

Place the FMAP symbol in the SLICE at row 7, column 3.

Schematic	LOC=SLICE_X7Y3
UCF	INST "\$1I323"LOC=SLICE_X2Y4, SLICE_X3Y4;

Example Two

Place the FMAP symbol in either the SLICE at row 2, column 4 or the SLICE at row 3, column 4.

Schematic	LOC=SLICE_X2Y4, SLICE_X3Y4
UCF	INST "top/dec0011" LOC=CLB_R2C4,CLB_R3C4;

Example Three

Place the FMAP symbol in the area bounded by SLICE X5Y5 in the upper left corner and SLICE X10Y8 in the lower right

Schematic	LOC=SLICE_X5Y5:SLICE_X10Y8
UCF	INST "\$3I27" LOC=SLICE_X5Y5:SLICE_X10Y8;

Multiplier Constraint Examples

This section applies to FPGA devices.

Multiplier constraints can be assigned from the schematic or through the UCF file. From the schematic, attach the LOC constraints to a multiplier symbol. The constraints are then passed into the netlist file and after mapping they are read by PAR. For more information on attaching LOC constraints, see the application user guide. Alternatively, in the constraints file a multiplier is identified by a unique instance name.

An FPGA multiplier has a different **XY** grid specification than slices and block RAMs.

- Spartan-3, Spartan-3A, and Spartan-3E devices are specified using **MULT18X18_X#Y#**
- Virtex-4 and Virtex-5 devices are specified using **DSP48_X#Y#**, where the **X** and **Y** coordinate values correspond to the multiplier grid array.

A multiplier located at **MULT18X18_X0Y1** is not located at the same site as a flip-flop located at **SLICE_X0Y1** or a block RAM located at **RAMB16_X0Y1**.

For example, assume you have a device with two columns of multipliers, each column containing two multipliers, where one column is on the right side of the chip and the other is on the left. The multiplier located in the lower left corner is **MULT18X18_X0Y0**. Because there are only two columns of multipliers, the multiplier located in the upper right corner is **MULT18X18_X1Y1**.

Schematic	LOC=MULT18X18_X0Y0
UCF	INST "/top-7/rq" LOC=MULT18X18_X0Y0;

ROM Constraint Examples

Memory constraints can be assigned from the schematic or through the UCF file.

From the schematic, attach the LOC constraints to the memory symbol. The constraints are then passed into the netlist file and after mapping they are read by PAR. For more information on attaching LOC constraints, see the application user guide.

Alternatively, in the constraints file memory is identified by a unique instance name. One or more memory instances of type ROM can be found in the input file. All memory macros larger than 16 x 1 or 32 x 1 are broken down into these basic elements in the netlist file.

In the following examples, the instance name of the ROM primitive is /top-7/rq.

Slice-Based XY Designations

Spartan-3 and higher and Virtex-4 and higher devices use slice-based XY grid designations. You can constrain a ROM to a specific slice, a range of slices, or a row or column of slices.

Example One

Place the memory in the SLICE_X1Y1. SLICE_X1Y1 is in the lower left corner of the device. You can apply a single-SLICE constraint such as this only to a 16 x 1 or 32 x 1 memory.

Schematic	LOC=SLICE_X1Y1
UCF	INST "/top-7/rq" LOC=SLICE_X1Y1;

Example Two

Place the memory in either SLICE_X2Y4 or SLICE_X7Y9.

Schematic	LOC=SLICE_X2Y4, SLICE_X7Y9
UCF	INST "/top-7/rq" LOC=SLICE_X2Y4, SLICE_X7Y9;

Example Three

Do not place the memory in column of slices whose X coordinate is 5. You can use the wildcard (*) character in place of either the X or Y coordinate value in the SLICE name to specify an entire row (Y*) or column (X*) of slices.

Schematic	PROHIBIT SLICE_X5Y*
UCF	CONFIG PROHIBIT=SLICE_X5Y*;

Block RAM (RAMBs) Constraint Examples

This section applies to FPGA devices

Block RAM constraints can be assigned from the schematic or through the UCF file. From the schematic, attach the LOC constraints to the block RAM symbol. The constraints are then passed into the netlist file. After mapping they are read by PAR. For more information on attaching LOC constraints, see the application user guide. Alternatively, in the constraints file a memory is identified by a unique instance name.

Spartan-3 and Higher Devices

An FPGA block RAM has a different XY grid specification than a slice or multiplier. It is specified using RAMB16_Xm Yn where the X and Y coordinate values correspond to the block RAM grid array. A block RAM located at RAMB16_X0Y1 is not located at the same site as a flip-flop located at SLICE_X0Y1.

For example, assume you have a device with two columns of block RAM, each column containing two blocks, where one column is on the right side of the chip and the other is on the left. The block RAM located in the lower left corner is RAMB16_X0Y0. Because there are only two columns of block RAM, the block located in the upper right corner is RAMB16_X1Y1.

Schematic	LOC=RAMB16_X0Y0 (for all FPGA devices except Virtex-5 devices) LOC=RAMB36_X0Y0 (for Virtex-5 devices)
UCF	INST "/top-7/rq" LOC=RAMB16_X0Y0;

Slice Constraint Examples

This section applies to all FPGA devices These are currently the only architectures that use the slice-based XY grid designations.

You can assign soft macros and flip-flops to a single slice location, a list of slice locations, or a rectangular block of slice locations.

Slice locations can be a fixed location or a range of locations. Use the following syntax to denote fixed locations.

SLICE_XmY n

where

m and *n* are the X and Y coordinate values, respectively

They must be less than or equal to the number of slices in the target device. Use the following syntax to denote a range of locations from the highest to the lowest.

SLICE_X mYn:SLICE_XmY n

Format of Slice Constraints

The following examples illustrate the format of slice constraints: LOC= and the slice location. If the target symbol represents a soft macro, the LOC constraint is applied to all appropriate symbols (flip-flops, maps) contained in that macro. If the indicated logic does not fit into the specified blocks, an error is generated.

Slice Constraints Example One

The following UCF statement places logic in the designated slice.

```
INST "instance_name" LOC=SLICE_X133Y10;
```

Slice Constraints Example Two

The following UCF statement places logic within the first column of slices. The asterisk (*) is a wildcard character

```
INST "instance_name" LOC=SLICE_X0Y*;
```

Slice Constraints Example Three

The following UCF statement places logic in any of the three designated slices. There is no significance to the order of the LOC statements.

```
INST "instance_name" LOC=SLICE_X0Y3, SLICE_X67Y120, SLICE_X3Y0;
```

Slice Constraints Example Four

The following UCF statement places logic within the rectangular block defined by the first specified slice in the lower left corner and the second specified slice towards the upper right corner.

```
INST "instance_name" LOC=SLICE_X3Y22:SLICE_X10Y55;
```

Slices Prohibited

You can prohibit PAR from using a specific slice, a range of slices, or a row or column of slices. Such prohibit constraints can be assigned only through the User Constraints File (UCF). Slices are prohibited by specifying a [Prohibit \(PROHIBIT\)](#) constraint at the design level, as shown in the following examples.

Slices Prohibited Example One

Do not place any logic in the SLICE_X0Y0. SLICE_X0Y0 is at the lower left corner of the device.

Schematic	None
UCF	CONFIG PROHIBIT=SLICE_X0Y0;

Slices Prohibited Example Two

Do not place any logic in the rectangular area bounded by SLICE_X2Y3 in the lower left corner and SLICE_X10Y10 in the upper right.

Schematic	None
UCF	CONFIG PROHIBIT=SLICE_X2Y3:SLICE_X10Y10;

Slices Prohibited Example Three

Do not place any logic in a slice whose location has 3 as the X coordinate. This designates a column of prohibited slices. You can use the wildcard (*) character in place of either the X or Y coordinate to specify an entire row (X*) or column (Y*) of slices.

Schematic	None
UCF	CONFIG PROHIBIT=SLICE_X3Y*;

Slices Prohibited Example Four

Do not place any logic in either SLICE_X2Y4 or SLICE_X7Y9.

Schematic	None
UCF	CONFIG PROHIBIT=SLICE_X2Y4, SLICE_X7Y9;

LOCATE (Locate)

The LOCATE (Locate) constraint:

- Is a basic placement constraint.
- Specifies any one of the following:
 - a single location
 - multiple single locations
 - a location range

Architecture Support

Applies to FPGA devices. Does not apply to CPLD devices.

Applicable Elements

- CLB
- IOB
- DCM
- Clock logic
- Macros

Propagation Rules

- When attached to a macro, LOCATE propagates to all elements of the macro.
- When attached to a primitive, LOCATE applies to the entire primitive.

Syntax Examples

The following examples show how to use this constraint with particular tools or methods. If a tool or method is not listed, you cannot use this constraint with it.

Single or Multiple Single Locations PCF Syntax

```
COMP "comp_name" LOCATE=[SOFT] "site_item1" ... "site_itemn" [LEVEL n];
COMPGRP "group_name" LOCATE=[SOFT] "site_item1" ... "site_itemn" [LEVEL n];
MACRO name LOCATE=[SOFT] "site_item1" "site_itemn" [LEVEL n];
```

Range of Locations PCF Syntax

```
COMP "comp_name" LOCATE=[SOFT] SITE "site_name" : SITE "site_name" [LEVEL n];
COMPGRP "group_name" LOCATE=[SOFT] SITE "site_name" : SITE "site_name"
[LEVEL n];
MACRO "macro_name" LOCATE=[SOFT] SITE "site_name" : SITE "site_name" [LEVEL
n];
```

where

- *site_name* is a component site (that is, a CLB or IOB location)
- *site_item* is one of the following:
 - SITE "site_name"
 - SITEGRP "site_group_name"
- *n* in LEVEL *n* is 0, 1, 2, 3, or 4

LOCK_PINS (Lock Pins)

The LOCK_PINS (Lock Pins) constraint:

- Instructs the implementation tools to not swap the pins of the LUT symbol to which it is attached.
- Is distinct from the Lock Pins process in ISE® Design Suite, which is used to preserve the existing pinout of a CPLD design.

Architecture Support

Applies to FPGA devices. Does not apply to CPLD devices.

Applicable Elements

Applies only to specific instances of LUT symbols.

Propagation Rules

Applies only to a single LUT instance.

Syntax Examples

The following examples show how to use this constraint with particular tools or methods. If a tool or method is not listed, you cannot use this constraint with it.

VHDL Syntax

Declare the VHDL constraint as follows:

```
attribute lock_pins: string;
```

Specify the VHDL constraint as follows:

```
attribute lock_pins of {component_name|label_name} : {component|label} is "all";
```

For more information about basic VHDL syntax, see [VHDL Attributes](#).

Verilog Syntax

Place the Verilog constraint immediately before the module or instantiation.

Specify the Verilog constraint as follows:

```
(* LOCK_PINS = "all" *)
```

For more information on basic Verilog syntax, see [Verilog Attributes](#).

UCF and NCF Syntax

- Using No Designator

```
INST "XSYM1" LOCK_PINS;
```
- Using the ALL Attribute

```
INST "XSYM1" LOCK_PINS='ALL';
```
- Using a PIN Assignment List

```
INST I_589 LOCK_PINS=I0:A2;  
INST I_894 LOCK_PINS=I3:A1,I2:A4;  
INST tvAgy LOCK_PINS=I0:A4,I1:A3,I2:A2,I3:A1;
```

LUTNM (Lookup Table Name)

The LUTNM (Lookup Table Name) constraint:

- Allows you to control the grouping of logical symbols into the LUT sites of Virtex®-5 devices.
- Is a string value property that is applied to two qualified symbols.
- Must be applied uniquely to two symbols within the design. These two symbols are implemented in a shared LUT site within a SLICE component.
- Is functionally similar to [BLKNM \(Block Name\)](#).

Architecture Support

Applies to Virtex-5 devices only.

Applicable Elements

Can be applied to:

- Two symbols that are unique within the design
- Two 5-input or smaller function generator symbols (LUT, ROM, or RAM) if the total number of unique input pins required for both symbols does not exceed 5 pins
- A 6-input read-only function generator symbol (LUT6, ROM64) in conjunction with a 5-input read-only symbol (LUT5, ROM32) if:
 - The total number of unique input pins required for both symbols does not exceed 6 inputs, and
 - The lower 32 bits of the 6-input symbol programming matches all 32 bits of the 5-input symbol programming.

Propagation Rules

LUTNM can be applied to two symbols that are unique within the design.

Syntax Examples

The following examples show how to use this constraint with particular tools or methods. If a tool or method is not listed, you cannot use this constraint with it.

Schematic Syntax

- Attach to a valid element or symbol type
- Attribute Name
`LUTNM`
- Attribute Value
`<user_defined>`

VHDL Syntax

Before using LUTNM, declare it with the following syntax placed after the architecture declaration, but before the begin statement in the top-level VHDL file:

```
attribute LUTNM: string;
```

Specify the VHDL constraint as follows:

```
attribute LUTNM of {LUT5_instance_name}: label is "value";
```

where

value

is any chosen name under which you want to group the two elements.

Example

```
architecture MY_DESIGN of top is
attribute LUTNM: string;
  attribute LUTNM of LUT5_inst1: label is "logic_group1";
  attribute LUTNM of LUT5_inst2: label is "logic_group1";
begin
-- LUT5: 5-input Look-Up Table
-- Virtex-5
-- Xilinx HDL Libraries Guide version 8.2i
LUT5_inst1 : LUT5
generic map (
  INIT => X"a49b44c1")
port map (
  O => aout, -- LUT output (1-bit)
  I0 => d(0), -- LUT input (1-bit)
  I1 => d(1), -- LUT input (1-bit)
  I2 => d(2), -- LUT input (1-bit)
  I3 => d(3), -- LUT input (1-bit)
  I4 => d(4) -- LUT input (1-bit)
);
-- End of LUT5_inst1 instantiation
-- LUT5: 5-input Look-Up Table
-- Virtex-5
-- Xilinx HDL Libraries Guide version 8.2i
LUT5_inst2 : LUT5
generic map (
  INIT => X"649d610a")
port map (
  O => bout, -- LUT output (1-bit)
  I0 => d(0), -- LUT input (1-bit)
  I1 => d(1), -- LUT input (1-bit)
  I2 => d(2), -- LUT input (1-bit)
  I3 => d(3), -- LUT input (1-bit)
  I4 => d(4) -- LUT input (1-bit)
);
-- End of LUT5_inst2 instantiation
END MY_DESIGN;
```

For more information about basic VHDL syntax, see [VHDL Attributes](#).

Verilog Syntax

Place the following attribute specification before the port declaration in the top-level Verilog code:

```
(* LUTNM = "value" *)
```

where

value is any chosen name under which you want to group the two elements.

Example

```
// LUT5: 5-input Look-Up Table
// Virtex-5
// Xilinx HDL Libraries Guide version 8.2i
(* LUTNM="logic_group1" *) LUT5 #(
  .INIT(32'ha49b44c1)
) LUT5_inst1 (
  .O(aout), // LUT output (1-bit)
  .I0(d[0]), // LUT input (1-bit)
  .I1(d[1]), // LUT input (1-bit)
  .I2(d[2]), // LUT input (1-bit)
  .I3(d[3]), // LUT input (1-bit)
  .I4(d[4]) // LUT input (1-bit)
);
// End of LUT5_inst1 instantiation
// LUT5: 5-input Look-Up Table
// Virtex-5
// Xilinx HDL Libraries Guide version 8.2i
(* LUTNM="logic_group1" *) LUT5 #(
  .INIT(32'h649d610a)
) LUT5_inst2 (
  .O(bout), // LUT output (1-bit)
  .I0(d[0]), // LUT input (1-bit)
  .I1(d[1]), // LUT input (1-bit)
  .I2(d[2]), // LUT input (1-bit)
  .I3(d[3]), // LUT input (1-bit)
  .I4(d[4]) // LUT input (1-bit)
);
// End of LUT5_inst2 instantiation
```

For more information about basic Verilog syntax, see [Verilog Attributes](#).

UCF and NCF Syntax

Placed on the output, or bi-directional port:

```
INST "LUT5_instance_name" LUTNM="value";
```

Where *value* is any chosen name under which you want to group the two elements.

Example

```
INST "LUT5_inst1" LUTNM="logic_group1";
```

```
INST "LUT5_inst2" LUTNM="logic_group1";
```

MAP (Map)

MAP (Map) is an advanced mapping constraint. Place MAP on an FMAP to specify whether pin swapping and the merging of other functions with the logic in the map are allowed. If merging with other functions is allowed, other logic can also be placed within the CLB, if space allows.

Architecture Support

Applies to FPGA devices. Does not apply to CPLD devices.

Applicable Elements

FMAP

Propagation Rules

Applies to the design element to which it is attached

Syntax

The following examples show how to use this constraint with particular tools or methods. If a tool or method is not listed, you cannot use this constraint with it.

UCF and NCF Syntax

```
INST "instance_name" MAP=[PUC | PUO | PLC | PLO];
```

where

- **PUC**

The CLB pins are unlocked (U) and the CLB is closed (C). The software *can* swap signals among the pins on the CLB, but *cannot* add or remove logic from the CLB.

- **PUO** (default)

The CLB pins are unlocked (U) and the CLB is open (O). The software *can* swap signals among the pins on the CLB, and *can* add or remove logic from the CLB.

- **PLC**

The CLB pins are locked (L) and the CLB is closed (C). The software *cannot* swap signals among the pins on the CLB, and *cannot* add or remove logic from the CLB.

- **PLO**

The CLB pins are locked (L) and the CLB is open (O). The software *cannot* swap signals among the pins on the CLB, but *can* add or remove logic from the CLB.

Currently, only **PUC** and **PUO** are observed. **PLC** and **PLO** are translated into **PUC** and **PUO**, respectively.

The following statement allows pin swapping, and ensures that no logic other than that defined by the original map is mapped into the function generators.

```
INST "$1I3245/map_of_the_world" map=puc;
```

MARK_DEBUG (Mark Debug)

The MARK_DEBUG (Mark Debug) constraint:

- Is a synthesis constraint
- Is used to mark nets for debugging with the ChipScope™ tool

In the PlanAhead™ software, nets marked for debugging are automatically listed in the:

- The ChipScope tool Unassigned Nets folder
- Set Up ChipScope Wizard

For more information, see:

PlanAhead User Guide (UG632)

Architecture Support

Applies to all FPGA devices. Does not apply to CPLD devices.

Applicable Elements

Applies to the net to which it is attached.

Propagation Rules

If the net is a bus, MARK_DEBUG is propagated to the individual signals comprising the bus.

Constraint Values

- **true**
The net is:
 - Preserved from optimization.
 - Marked for debugging with the ChipScope tool.
- **false**
The constraint is ignored.
- **soft** (XST only)
The net is marked for debugging *only if it is not optimized away during XST synthesis.*

Syntax Examples

The following examples show how to use this constraint with particular tools or methods. If a tool or method is not listed, you cannot use this constraint with it.

VHDL Syntax Example

Declare the VHDL constraint as follows:

```
attribute mark_debug : string;
```

Specify the VHDL constraint as follows:

```
attribute mark_debug of signal_name : signal is  
"{TRUE|FALSE|SOFT}";
```

Verilog Syntax Example

Place the Verilog constraint immediately before the module or instantiation.

Specify the Verilog constraint as follows:

```
(* mark_debug = "{TRUE|FALSE|SOFT}" *) wire wire_name ;
```

XCF Syntax Example

Specify the XCF constraint as follows:

```
BEGIN MODEL "entity_name"  
NET "signal_name" mark_debug = "{TRUE|FALSE|SOFT}" ;  
END;
```

MAX_FANOUT (Max Fanout)

MAX_FANOUT (Max Fanout) limits the fanout of nets or signals. Depending on the value of the constraint, both XST and MAP limit the fanout of a net when this constraint is applied. The value can either be an integer (XST only) or REDUCE (MAP only).

MAX_FANOUT for XST

Default integer values for XST are shown in the following table. Max Fanout is both a global and a local constraint in XST.

Max Fanout Default Values Devices

	Default Value
Spartan®-3, Spartan-3E, Spartan-3A, Spartan-3A D	500
Virtex®-4	500
Virtex-5	100000 (One Hundred Thousand)

Large fanouts can cause routability problems. XST tries to limit fanout by duplicating gates or by inserting buffers. This limit is not a technology limit but a guide to XST. It may happen that this limit is not exactly respected, especially when this limit is small (less than 30).

In most cases, fanout control is performed by duplicating the gate driving the net with a large fanout. If the duplication cannot be performed, buffers are inserted. These buffers are protected against logic trimming at the implementation level by defining a [Keep \(KEEP\)](#) attribute in the NGC file. If the register replication option is set to **no**, only buffers are used to control fanout of flip-flops and latches.

Max Fanout is global for the design, but you can control maximum fanout independently for each entity or module or for given individual signals by using constraints.

If the actual net fanout is less than the Max Fanout value, XST behavior depends on how Max Fanout is specified.

- If the value of Max Fanout is set in ISE® Design Suite in the command line, or is attached to a specific hierarchical block, XST interprets its value as a guidance.
- If Max Fanout is attached to a specific net, XST does not perform logic replication. Putting Max Fanout on the net may prevent XST from having better timing optimization.

For example, suppose that the critical path goes through the net, which actual fanout is 80 and set Max Fanout value to 100. If Max Fanout is specified in ISE Design Suite, XST may replicate it, trying to improve timing. If Max Fanout is attached to the net itself, XST does not perform logic replication.

MAX_FANOUT for MAP

MAX_FANOUT can also drive MAP to limit fanout by duplicating registers and/or gates. The MAP register duplication option (**-register_duplication**) must be enabled and MAX_FANOUT constraints must be applied locally to nets for this to occur. When used during MAP, only the value of REDUCE is accepted. When MAX_FANOUT = "REDUCE", MAP limits fanout if it determines that it can provide an improvement in performance with out causing problems in fitting the design. Review the physical synthesis report (*PSR) generated by MAP to review whether or not MAX_FANOUT = "REDUCE" caused fanout reduction to actually occur.

Architecture Support

Applies to all FPGA devices. Does not apply to CPLD devices.

Applicable Elements

When the value is an integer, Max Fanout applies globally, or to a VHDL entity, a Verilog module, or signal.

When the value is **REDUCE**, Max Fanout applies only to a signal.

Propagation Rules

Applies to the entity, module, or signal to which it is attached.

Syntax Examples

The following examples show how to use this constraint with particular tools or methods. If a tool or method is not listed, you cannot use this constraint with it.

VHDL Syntax

Declare the VHDL constraint as follows:

```
attribute max_fanout: string;
```

Specify the VHDL constraint as follows:

```
attribute max_fanout of {signal_name|entity_name}: {signal|entity} is "integer";
```

For more information about basic VHDL syntax, see [VHDL Attributes](#).

Verilog Syntax

Place the Verilog constraint immediately before the module or instantiation.

Specify the Verilog constraint as follows:

```
(* max_fanout = "integer" *)
```

XCF Syntax Example One

```
MODEL "entity_name" max_fanout=integer;
```

XCF Syntax Example Two

```
BEGIN MODEL "entity_name"  
NET "signal_name" max_fanout=integer;  
END;
```

XST Command Line Syntax

Define globally with the **-max_fanout** command line option of the **run** command:

```
-max_fanout integer
```

ISE Design Suite Syntax

Define globally in ISE Design Suite in **Process > Properties > Xilinx-Specific Options > Max Fanout**.

UCF Syntax

When used with the MAP Register Duplication option, specify MAX_FANOUT in the User Constraints File (UCF) as follows:

```
NET "signal_name" max_fanout=REDUCE;
```

MAXDELAY (Maximum Delay)

MAXDELAY (Maximum Delay) defines the maximum allowable delay on a net.

Architecture Support

Applies to FPGA devices. Does not apply to CPLD devices.

Applicable Elements

Applies to the net to which it is attached.

Propagation Rules

Applies to the net to which it is attached

Syntax

The following examples show how to use this constraint with particular tools or methods. If a tool or method is not listed, you cannot use this constraint with it.

Schematic Syntax

- Attach to a net
- Attribute Name: **MAXDELAY**
- Attribute Values: *value units*

where

value is the numerical time delay

units are:

- **micro**
- **ms**
- **ns**
- **ps**

VHDL Syntax

Declare the VHDL constraint as follows:

```
attribute maxdelay: string;
```

Specify the VHDL constraint as follows:

```
attribute maxdelay of signal_name: signal is "value [units]";
```

where

- *value* is any positive integer
- *units* are:
 - **ps**
 - **ns** (default)
 - **micro**
 - **ms**
 - **GHz**
 - **MHz**
 - **kHz**

For more information on basic VHDL syntax, see [VHDL Attributes](#).

Verilog Syntax

Place the Verilog constraint immediately before the module or instantiation.

Specify the Verilog constraint as follows:

```
(*MAXDELAY = "value [units]" *)
```

where

- *value* is any positive integer
- *units* are:
 - **ps**
 - **ns** (default)
 - **micro**
 - **ms**
 - **GHz**
 - **MHz**
 - **kHz**

For more information on basic Verilog syntax, see [Verilog Attributes](#).

UCF and NCF Syntax

```
NET "net_name" MAXDELAY=value units;
```

where

- *value* is the numerical time delay.
- *units* are:
 - **micro**
 - **ns**
 - **ms**
 - **ps**

The following statement assigns a maximum delay of 10 nanoseconds to the net **\$\$SIG_4**.

```
NET "$1I3245/$SIG_4" MAXDELAY=10 ns ;
```

PCF Syntax

item MAXDELAY = *maxvalue* [PRIORITY *integer*];

where

- *item* can be:
 - ALLNETS
 - NET *name*
 - TIMEGRP *name*
 - ALLPATHS
 - PATH *name*
 - *path specification*
- *maxvalue* can be a:
 - numerical time value with units of micro, ms, ps, or ns
 - numerical frequency value with units of GHz, MHz, or KHz
 - TSidentifier

Constraints Editor Syntax

To open Constraints Editor, select ISE® Design Suite > Processes > User Constraints > Exceptions > Timing Constraints > Nets.

FPGA Editor Syntax

To set MAXDELAY to all paths or nets, select File > Main Properties > Global Physical Constraints.

To set MAXDELAY to a selected path or net, with a routed net selected, select Edit > Properties of Selected Items > Physical Constraints.

MAXPT (Maximum Product Terms)

The MAXPT (Maximum Product Terms) constraint:

- Is an advanced constraint.
- Applies to CPLD devices only.
- Specifies the maximum number of product terms the fitter is permitted to use when collapsing logic into the node to which MAXPT is applied.
- Overrides the Collapsing P-term Limit setting in ISE® Design Suite for the attached node.

Architecture Support

Applies to CPLD devices only. Does not apply to FPGA devices.

Applicable Elements

Applies to signals.

Propagation Rules

Applies to the signal to which it is attached.

Syntax Examples

The following examples show how to use this constraint with particular tools or methods. If a tool or method is not listed, you cannot use this constraint with it.

VHDL Syntax

Declare the VHDL constraint as follows:

```
attribute maxpt: integer;
```

Specify the VHDL constraint as follows:

```
attribute maxpt of signal_name : signal is "integer";
```

integer is any positive integer

For more information about basic VHDL syntax, see [VHDL Attributes](#).

Verilog Syntax

Place the Verilog constraint immediately before the module or instantiation.

Specify the Verilog constraint as follows:

```
(* MAXPT = "integer" *)
```

integer is any positive integer

For more information about basic Verilog syntax, see [Verilog Attributes](#).

UCF and NCF Syntax

```
Net "signal_name" maxpt=integer;
```



MAXSKEW (Maximum Skew)

The MAXSKEW (Maximum Skew) constraint:

- Is a timing constraint
- Is used to control the maximum amount of skew on a net.
- Is commonly used to control the skew of local clocks, or clocks that are not on the global clock network.
- Is not necessary, and is not recommended, for global clock networks.

Skew is the difference between the delays of all loads driven by the net. Because the constraint identifies all loads driven by the net, skew may be reported between loads that have no logical connection. You can control the maximum allowable skew on a net by attaching MAXSKEW directly to the net.

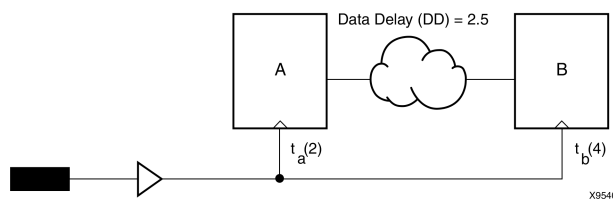
To understand what MAXSKEW defines, consider the following example.



In the preceding diagram, for $t_a(2)$, 2 ns is the maximum delay for the Register A clock. For $t_b(4)$, 4 ns is the maximum delay for the Register B clock. MAXSKEW defines the maximum of t_b minus the maximum of t_a , that is, $4-2=2$.

In some cases, relative minimum delays are used on a net for setup and hold timing analysis. When MAXSKEW is applied to network resources which use relative minimum delays, MAXSKEW takes relative minimum delays into account in the calculation of skew.

Overuse of MAXSKEW, or too tight of a requirement (value), can cause long PAR runtimes.

Architecture Support

Applies to FPGA devices. Does not apply to CPLD devices.

Applicable Elements

Nets

Propagation Rules

Applies to the net to which it is attached.

yntax

The following examples show how to use this constraint with particular tools or methods. If a tool or method is not listed, you cannot use this constraint with it.

Schematic Syntax

- Attach to a net
- Attribute Name
MAXSKEW
- Attribute Values
allowable_skew
units
where
 - **allowable_skew** is the timing requirement
 - **units** are ms, micro, ns (default), or ps

VHDL Syntax

Declare the VHDL constraint as follows:

attribute maxskew: string;

Specify the VHDL constraint as follows:

attribute maxskew of *signal_name* : signal is "allowable_skew [units]";

where

- **allowable_skew** is the timing requirement
- **units** are ms, micro, ns (default), or ps

For more information about basic VHDL syntax, see [VHDL Attributes](#).

Verilog Syntax

Place the Verilog constraint immediately before the module or instantiation.

Specify the Verilog constraint as follows:

(* **MAXSKEW = "allowable_skew [units] "** *)

where

- **allowable_skew** is the timing requirement
- **units** are ms, micro, ns (default), or ps

For more information about basic Verilog syntax, see [Verilog Attributes](#).

UCF and NCF Syntax

NET "net_name" MAXSKEW=allowable_skew [units];

where

- **allowable_skew** is the timing requirement
- **units** are ms, micro, ns (default), or ps

The following statement specifies a maximum skew of 3 ns on net \$SIG_6.

NET "\$I13245/\$SIG_6" MAXSKEW=3 ns;

Constraints Editor Syntax

For information on setting constraints in Constraints Editor, including syntax, see the Constraints Editor Help.

FPGA Editor Syntax

To set constraints in FPGA Editor, select **Edit > Properties of Selected Items**. With a routed net selected, you can set MAXSKEW from the Physical Constraints tab.

MCB Performance (MCB_PERFORMANCE)

Note This constraint applies to Spartan®-6 devices only.

Spartan-6 devices have a Memory Controller Block (MCB) which can support two different performance targets depending on voltage settings and conditions on the V_{CCINT} power supply. The performance targets are listed in the device [data sheet](#). To specify the desired MCB performance level in the ISE® Design Suite tools, use the MCB Performance (MCB_PERFORMANCE) configuration constraint in the User Constraints File (UCF) supplied to the tools upon implementation.

MCB_PERFORMANCE is supported in the User Constraints File (UCF) only.

The syntax is as follows:

```
CONFIG MCB_PERFORMANCE=[ STANDARD | EXTENDED ] ;
```

MCB_PERFORMANCE can be specified as follows:

- None

If MCB_PERFORMANCE is not specified, the default is STANDARD.

- STANDARD

To target the MCB to normal performance and the full voltage range on V_{CCINT} as shown in the device [data sheet](#), specify STANDARD in the UCF.

```
CONFIG MCB_PERFORMANCE= STANDARD;
```

- EXTENDED

To target the MCB to a faster performance, specify EXTENDED in the UCF.

```
CONFIG MCB_PERFORMANCE=EXTENDED;
```

There are explicit voltage requirements when using EXTENDED. For more information, see the device [data sheet](#).

Note V_{CCINT} voltage settings in the UCF and timing tools, and as reported by the ISE Design Suite tools, are independent of this setting. They may report a different voltage for analysis than required by the MCB_PERFORMANCE setting. Voltage requirements of this rail must be set properly based on both this attribute and the Voltage settings for timing analysis.

MIODELAY_GROUP (MIODELAY Group)

The MIODELAY_GROUP (MIODELAY Group) constraint:

- Is a design implementation constraint.
- Combines two or more [IODELAY_GROUP](#) constraints into a single Master [IODELAY_GROUP](#) to enable automatic replication and placement of IDELAYCTRL constraints in a design.

Architecture Support

MIODELAY_GROUP applies to Virtex®-4 and Virtex-5 devices. For Virtex-4 devices, MIODELAY_GROUP is supported only when using the Timing Driven Pack and Placement Option in MAP.

Applicable Elements

MIODELAY_GROUP is applied to two or more defined IODELAY_GROUPS.

Propagation Rules

MIODELAY_GROUP is applied to an existing [IODELAY_GROUP](#). The MIODELAY_GROUP is propagated to all of the design elements that belonged to the original [IODELAY_GROUP](#). It is illegal to attach MIODELAY_GROUP to a net, signal, or pin.

Syntax Examples

The following examples show how to use this constraint with particular tools or methods. If a tool or method is not listed, you cannot use this constraint with it.

UCF Syntax

```
MIODELAY_GROUP "master_group_name" = iodelay_group1 iodelay_group2 ... ;
```

where

- *master_group_name*
 - represents the master group being defined
 - contains all of the elements in *iodelay_group1* and *iodelay_group2*
- *iodelay_group1* and *iodelay_group2* are predefined IODELAY groups

NODELAY (No Delay)

The NODELAY (No Delay) constraint:

- Is an advanced mapping constraint.
 - The default configuration of IOB flip-flops in designs includes an input delay that results in an external hold time on the input data path. This delay can be removed by placing NODELAY on input flip-flops or latches, resulting in a smaller setup time but a positive hold time. The input delay element is active in the default configuration for Spartan®-3, Spartan-3A, and Spartan-3E devices.
- Can be attached to I/O symbols and the following special function access symbols:
 - TDI
 - TMS
 - TCK

Architecture Support

Spartan-3, Spartan-3A, and Spartan-3E devices are supported.

IOBDELAY=NONE, which is applicable to all FPGA devices, is the preferred method of applying this constraint. For more information see [IOBDELAY \(Input Output Block Delay\)](#).

Applicable Elements

Input register

You can also attach NODELAY to a net connected to a pad component in a User Constraints File (UCF). NGDBuild transfers the constraint from the net to the pad instance in the NGD file so that it can be processed by the mapper. Use the following UCF syntax:

```
NET "net_name" NODELAY;
```

Propagation Rules

NODELAY is illegal when attached to a net or signal except when the net or signal is connected to a pad. In this case, NODELAY is treated as attached to the pad instance.

When attached to a design element, NODELAY is propagated to all applicable elements in the hierarchy within the design element.

Syntax Examples

The following examples show how to use this constraint with particular tools or methods. If a tool or method is not listed, you cannot use this constraint with it.

Schematic Syntax

- Attach to a valid instance
- Attribute Name
NODELAY
- Attribute Values
TRUE
FALSE

VHDL Syntax

Declare the VHDL constraint as follows:

```
attribute nodelay: string;
```

Specify the VHDL constraint as follows:

```
attribute nodelay of {component_name|signal_name|label_name} :  
{component|signal|label} is "{TRUE|FALSE}";
```

For more information about basic VHDL syntax, see [VHDL Attributes](#).

Verilog Syntax

Place the Verilog constraint immediately before the module or instantiation.

Specify the Verilog constraint as follows:

```
(* NODELAY = "{TRUE|FALSE}" *)
```

For more information about basic Verilog syntax, see [Verilog Attributes](#).

UCF and NCF Syntax

The following statement specifies that IOB register **inreg67** not have an input delay.

```
INST "$1I87/inreg67" NODELAY;
```

The following statement specifies that there be no input delay to the pad that is attached to **net1**.

```
NET "net1" NODELAY;
```

XCF Syntax

```
BEGIN MODEL "entity_name "
```

```
NET "signal_name" nodelay=true;
```

```
INST "instance_name" nodelay=true;
```

```
END;
```

NOREDUCE (No Reduce)

The NOREDUCE (No Reduce) constraint:

- Is a fitter and synthesis constraint.
- Prevents minimization of redundant logic terms that are typically included in a design to avoid logic hazards or race conditions.
- Identifies the output node of a combinatorial feedback loop to ensure correct mapping.

When constructing combinatorial feedback latches in a design, always apply NOREDUCE to the latch's output net and include redundant logic terms when necessary to avoid race conditions.

Architecture Support

Applies to CPLD devices only. Does not apply to FPGA devices.

Applicable Elements

Applies to the net to which it is attached.

Propagation Rules

This constraint is a net constraint. Any attachment to a design element is illegal.

Syntax Examples

The following examples show how to use this constraint with particular tools or methods. If a tool or method is not listed, you cannot use this constraint with it.

Schematic Syntax

- Attach to a net
- Attribute Name
NOREDUCE
- Attribute Values
 - TRUE
 - FALSE

VHDL Syntax

Declare the VHDL constraint as follows:

```
attribute NOREDUCE: string;
```

Specify the VHDL constraint as follows:

```
attribute NOREDUCE of signal_name: signal is "{TRUE|FALSE}";
```

For more information about basic VHDL syntax, see [VHDL Attributes](#).

Verilog Syntax

Place the Verilog constraint immediately before the module or instantiation.

Specify the Verilog constraint as follows:

```
(* NOREDUCE = "{TRUE|FALSE}" *)
```

For more information about basic Verilog syntax, see [Verilog Attributes](#).

UCF and NCF Syntax

The following statement specifies that there be no Boolean logic reduction or logic collapse from the net named \$SIG_12 forward.

```
NET "$SIG_12" NOREDUCE;
```

XCF Syntax

```
BEGIN MODEL "entity_name"
```

```
NET "signal_name" noreduce={true | false};
```

```
END;
```

OFFSET IN (Offset In)

The OFFSET IN (Offset In) constraint:

- Specifies the timing requirements of an input interface to the FPGA device.
- Specifies the clock and data timing relationship at the external pads of the FPGA device.

An OFFSET IN constraint specification checks the setup and hold timing requirements of all synchronous elements associated with the constraint.

The OFFSET IN constraint is specified using a clock net name. The clock net associated with the OFFSET IN constraint is the external clock pad. Because the constraint specifies the clock and data relationship at the external pads of the FPGA, the OFFSET IN constraint cannot be specified using an internal clock net. However, the OFFSET IN constraint automatically accounts for any phase or delay adjustments on the clock path due to components such as the DCM, PLL, MMCM, or IDELAY when analyzing the setup and hold timing requirements at the capturing synchronous element. In addition, the constraint propagates through the clock network and automatically applies to all clocks derived from the original external clock.

The OFFSET IN constraint is global in scope by default. In the global OFFSET IN constraint, all synchronous elements that are clocked by the specified clock net, and capture external data, are covered by the constraint. The scope of the synchronous elements covered by the constraint can be restricted by specifying time groups on a subset of input data pads, a subset of the capturing synchronous elements, or both.

Architecture Support

Applies to all FPGA devices and all CPLD devices.

Applicable Elements

- Global
- Net-Specific
- Pad Time Group

Syntax Examples

The following examples show how to use this constraint with particular tools or methods. If a tool or method is not listed, you cannot use this constraint with it.

Although User Constraints File (UCF) examples are given below, Xilinx® recommends specifying the OFFSET IN constraint using Constraints Editor.

Global Method

The global method is the default OFFSET IN constraint. The global OFFSET IN constraint applies to all synchronous elements that capture incoming data and are triggered by the specified clock signal.

Global Method UCF Syntax Example

```
OFFSET = IN "offset_time" [units] [VALID <datavalid_time> [UNITS]] {BEFORE|AFTER}
"clk_name" [{RISING|FALLING}];
```

Global Method PCF Syntax Example

```
OFFSET = IN "offset_time" [units] [VALID <datavalid_time> [UNITS]] {BEFORE|AFTER}
COMP "clk_job_name" [{RISING|FALLING}];
```

where

- “*offset_time*” [*units*] is the difference in time between the capturing clock edge and the start of the data to be captured. The time can be specified with or without explicitly declaring the units. If no units are specified, the default value is nanoseconds. The valid values for this parameter are: ps, ns, micro, and ms.
- [VALID <*datavalid_time*> [UNITS]] is the valid duration of the data to be captured. This field is required for a hold time verification of the input interface. This value can be specified with or without explicitly declaring the units. If no units are specified, the default value is nanoseconds. The valid values for this field are: ps, ns, micro, and ms.
- BEFORE|AFTER defines the timing relationship of the start of data to the clock edge. The best method of defining the clock and data relationship is to use the BEFORE option. BEFORE describes the time the data begins to be valid relative to the capturing clock edge. Positive values of BEFORE indicate the data begins prior to the capturing clock edge. Negative values of BEFORE indicate the data begins following the capturing clock edge.

Note OFFSET = IN can be used with the AFTER option only if the RISING or FALLING qualifiers are not used.

- “*clk_name*” defines the fully hierarchical name of the input clock pad net.
- RISING|FALLING are the optional keywords used to define the capturing clock edge in which the clock and data relationship is specified against. In addition, these use of these keywords automatically partition rising and falling edge registers in dual data rate (DDR) interfaces into separate groups for analysis.

Note The RISING|FALLING keywords can be used only with the BEFORE type of OFFSET IN constraints.

Input Group Method

When a group of inputs captured by the same clock have a shared timing requirement, the inputs can be grouped together to create a single timing constraint. The inputs can be grouped together by input signal names using pad groups, or by the synchronous elements using register groups. By grouping separate signals together into a single time group, the memory and runtime of the implementation tools is reduced. In addition, the timing report will contain bus-based skew and clock centering information.

Input Group Method UCF Syntax Example

```
[TIMEGRP "pad_groupname") OFFSET = IN "offset_time" [units] [VALID <datavalid_time>
[UNITS]] {AFTER "clk_name" [TIMEGRP "reg_groupname") | BEFORE "clk_name"
[TIMEGRP "reg_groupname") [{RISING|FALLING}}];
```

Input Group Method PCF Syntax Example

```
[TIMEGRP "inputpad_grpname") OFFSET = IN "offset_time" [units] [VALID
<datavalid_time> [UNITS]] {AFTER COMP "clk_iob_name" [TIMEGRP "reg_groupname")
| BEFORE COMP "clk_iob_name" [TIMEGRP "reg_groupname") [{RISING|FALLING}}];
```

where

- [TIMEGRP "*pad_groupname*") is the optional input pad time group. This time group can be used to limit the scope of the OFFSET IN constraint to only the synchronous elements fed by the input pad nets contained in the timegroup.
- [TIMEGRP "*reg_groupname*") is the optional synchronous element time group. This time group can be used to limit the scope of the OFFSET IN constraint to only the synchronous elements which capture input data with the specified clock and are contained in the time group.

Net Specific Method

OFFSET IN can also be used to specify an input constraint for a specific data net in a schematic, a specific input pad net in the UCF, or a specific input component in the PCF file.

Schematic Syntax When Attached to a Net

```
OFFSET = IN "offset_time" [units] [VALID <datavalid_time> [UNITS]] {BEFORE|AFTER}
"clk_name" [TIMEGRP "reg_groupname"] [{RISING|FALLING}];
```

Net Specific Method UCF Syntax Example

```
NET "pad_net_name" OFFSET = IN "offset_time" [units] [VALID <datavalid_time> [UNITS]]
{BEFORE|AFTER} "clk_name" [TIMEGRP "reg_groupname"] [{RISING|FALLING}];
```

Net Specific Method PCF Syntax Example

```
COMP "pad_net_name" OFFSET = IN "offset_time" [units] [VALID <datavalid_time>
[UNITS]] {BEFORE|AFTER} COMP "clk_iob_name" [TIMEGRP "reg_groupname"]
[{RISING|FALLING}];
```

where

- *pad_net_name* is the name of the input data net attached to the pad.
For the definition of the other variables and keywords, see *Global Method* above.
- The PCF specification uses IO Blocks (COMPs) instead of NETs.
If the IOB COMP name is omitted in the PCF, or the NET name is omitted in the UCF, the OFFSET IN specification is assumed to be global.

UCF Source Synchronous DDR Edge Aligned Example

The Source Synchronous Dual Data Rate (DDR) Edge aligned case consists of an interface where the clock is sent from the transmitting device edge aligned with the data to the FPGA. In a dual data rate interface, data is captured with both the rising and falling clock edges. In the DDR case, separate OFFSET IN constraints must be defined for the rising and falling clock edge registers capturing the data. The use of the **RISING** and **FALLING** keywords with the OFFSET IN constraint simplifies this task.

Example Waveform

In this example a dual data rate interface is shown with a clock period of 5 ns and 50/50 duty cycle. The rising and falling data is valid for 2 ns and is centered in the high and low portion of the clock waveform. This results in a 250 ps margin before and after data valid window.

Rising Edge Constraints

The rising edge OFFSET IN constraint defines the time that the data becomes valid prior to rising clock edge used to capture the data. In this example, the data becomes valid 250 ps after the rising clock edge. This results in an *OFFSET IN BEFORE* value of -250 ps with the value negative because it begins after the clock edge. Once the data begins, it remains valid for 2 ns. This results in a *VALID* value of 2 ns. The **RISING** keyword is used with this constraint to indicate that the constraint applies to only the rising edge synchronous elements, and that the *OFFSET IN BEFORE* value is specified to the rising clock edge.

Falling Edge Constraints

The falling edge **OFFSET IN** constraint defines the time that the data becomes valid prior to falling clock edge used to capture the data. In this example, the data becomes valid 250 ps after the falling clock edge. This results in an *OFFSET IN BEFORE* value of -250 ps with the value negative because it begins after the clock edge. Once the data begins, it remains valid for 2 ns. This results in a *VALID* value of 2 ns. The **FALLING** keyword is used with this constraint to indicate that the constraint applies to only the falling edge synchronous elements, and that the *OFFSET IN BEFORE* value is specified to the falling clock edge.

For more information about the **RISING** and **FALLING** keywords, see the *Timing Constraints User Guide*.

UCF Syntax

The complete UCF syntax of the clock **PERIOD** and **OFFSET IN** constraint for the example is shown below.

```
NET "clock" TNM_NET = CLK;
TIMESPEC TS_CLK = PERIOD CLK 5.0 ns HIGH 50%;

OFFSET = IN -250 ps VALID 2 ns BEFORE clock RISING;
OFFSET = IN -250 ps VALID 2 ns BEFORE clock FALLING
```

UCF Source Synchronous DDR Center Aligned Example

The Source Synchronous Dual Data Rate (DDR) Center aligned case consists of an interface where the clock is sent from the transmitting device aligned with the center of the data. In a dual data rate interface, data is captured with both the rising and falling clock edges. In the DDR case, separate **OFFSET IN** constraints must be defined for the rising and falling clock edge registers capturing the data. Using the **RISING** and **FALLING** keywords with the **OFFSET IN** constraint simplifies this task.

Example Waveform

In this example a dual data rate interface is shown with a clock period of 5 ns and 50/50 duty cycle. The rising and falling data is valid for 2 ns and is centered over the high and low clock edges. This results in a 250 ps margin before and after data valid window.

Rising Edge Constraints

The rising edge **OFFSET IN** constraint defines the time that the data becomes valid prior to rising clock edge used to capture the data. In this example, the data becomes valid 1 ns before the rising clock edge. This results in an *OFFSET IN BEFORE* value of 1 ns with the value positive because it begins before the clock edge. Once the data begins, it remains valid for 2 ns. This results in a *VALID* value of 2 ns. The **RISING** keyword is used with this constraint to indicate that the constraint applies to only the rising edge synchronous elements, and that the *OFFSET IN BEFORE* value is specified to the rising clock edge.

Falling Edge Constraints

The falling edge **OFFSET IN** constraint defines the time that the data becomes valid prior to falling clock edge used to capture the data. In this example, the data becomes valid 1 ns before the falling clock edge. This results in an *OFFSET IN BEFORE* value of 1 ns with the value positive because it begins before the clock edge. Once the data begins, it remains valid for 2 ns. This results in a *VALID* value of 2 ns. The **FALLING** keyword is used with this constraint to indicate that the constraint applies to only the falling edge synchronous elements, and that the *OFFSET IN BEFORE* value is specified to the falling clock edge.

UCF Syntax

The complete UCF syntax of the clock PERIOD and OFFSET IN constraint for the example is shown below.

```
NET "clock" TNM_NET = CLK;
TIMESPEC TS_CLK = PERIOD CLK 5.0 ns HIGH 50%;

OFFSET = IN 1 ns VALID 2 ns BEFORE clock RISING;
OFFSET = IN 1 ns VALID 2 ns BEFORE clock FALLING;
```

UCF System Synchronous SDR Examples

The System Synchronous Single Data Rate (SDR) case consists of an interface where the clock is sent from the transmitting device with one clock edge and captured by the FPGA with the next clock edge. In the single data rate interface data is sent once per clock cycle and requires only one OFFSET IN constraint.

Example Waveform

In this example a single data rate interface is shown with a clock period of 5 ns and 50/50 duty cycle. The data is valid for 4 ns and begins 500 ps after the transmitting clock edge.

Input Constraints

The OFFSET IN constraint defines the time that the data becomes valid prior to rising clock edge used to capture the data. In this example, the data becomes valid 500 ps after the transmitting clock edge, or 4.5 ns before the clock edge used to capture the data. This results in an *OFFSET IN BEFORE* value of 4.5 ns with the value positive because it begins before the clock edge. Once the data begins, it remains valid for 4 ns. This results in a *VALID* value of 4 ns.

UCF Syntax

The complete UCF syntax of the clock PERIOD and OFFSET IN constraint for the example is shown below.

```
NET "clock" TNM_NET = CLK;
TIMESPEC TS_CLK = PERIOD CLK 5.0 ns HIGH 50%;
OFFSET = IN 4.5 ns VALID 4 ns BEFORE clock;
```

Schematic Syntax

- Attach to a specific net
- Attribute Name
 - OFFSET**
- Attribute Values
 - IN|OUT
 - BEFORE|AFTER *clk_pad_netname*

XCF Syntax

The XCF syntax is the same as the UCF syntax. However, the XCF syntax supports only the *OFFSET IN BEFORE* method.

PlanAhead Syntax

For more information about using the PlanAhead software to create constraints, see *Floorplanning the Design* in the *PlanAhead User Guide (UG632)*. See [PlanAhead](#) in this Guide for information about:

- Defining placement constraints
- Assigning placement constraints
- Defining I/O pin configurations
- Floorplanning and placement constraints

Constraints Editor Syntax

For information on setting constraints in Constraints Editor, including syntax, see the Constraints Editor Help.

OFFSET OUT (Offset Out)

The OFFSET OUT (Offset Out) constraint:

- Specifies the timing requirements of an output interface from the FPGA device.
- Specifies the time from the clock edge at the input pin of the FPGA device until data becomes valid at the output pin of the FPGA device.
- Is specified using a clock net name.

The clock net associated with OFFSET OUT is the external clock pad. Because the constraint specifies the time from the clock edge at the input pin of the FPGA device to the data at the output pin of the FPGA device, OFFSET OUT cannot be specified using an internal clock net. However, OFFSET OUT automatically accounts for any phase or delay adjustments on the clock path due to components such as the DCM, PLL, MMCM, or IDELAY when analyzing the output timing requirements. In addition, the constraint propagates through the clock network and automatically applies to all clocks derived from the original external clock.

OFFSET OUT is global in scope by default. In the global OFFSET OUT, all synchronous elements that are clocked by the specified clock net, and transmit external data, are covered by the constraint. The scope of the synchronous elements covered by the constraint can be restricted by specifying time groups on a subset of output data pads, a subset of the transmitting synchronous elements, or both.

Architecture Support

Applies to all FPGA devices and all CPLD devices.

Applicable Elements

- Global
- Nets
- Time groups

Syntax

The following examples show how to use this constraint with particular tools or methods. If a tool or method is not listed, you cannot use this constraint with it.

Although UCF examples are provided, Xilinx® recommends using the Constraints Editor to specify OFFSET OUT.

Global Method

The global method is the default OFFSET OUT. The global OFFSET OUT applies to all synchronous elements that transmit outgoing data and are triggered by the specified clock signal.

Note You can use **BEFORE** with the **RISING** or **FALLING** keywords. However, if the **REFERENCE_PIN** keyword is used, then you must use the **AFTER** keyword and cannot use the **BEFORE** keyword.

UCF Syntax Example

```
OFFSET = OUT "offset_time" [units] {BEFORE "clk_name" | AFTER "clk_name"
[REFERENCE_PIN "ref_pin"]} [{RISING | FALLING}];
```

PCF Syntax Example

```
OFFSET = OUT "offset_time" [units] {BEFORE COMP "clk_iob_name" | AFTER COMP
"clk_iob_name" [REFERENCE_PIN "ref_pin"]} [{RISING | FALLING}];
```

where

- *offset_time* [units] is an optional parameter that defines the time from the clock edge at the input pin of the FPGA device until data first becomes valid at the data output pin.
 - If the *offset_time* value is specified:
 - ◆ A timing constraint is applied to these paths
 - ◆ Errors against that constraint are reported
 - If the *offset_time* value is omitted:
 - ◆ A timing constraint is not generated
 - ◆ The output timing and bus skew of the interface are reported

The report-only option is best used in source synchronous interfaces where the clock to output time is of a lesser concern than the skew of the output bus.

- **BEFORE** | **AFTER** defines the timing relationship from the clock edge to the start of data.

The best method for defining the clock and data requirement is to use the **AFTER** option. **AFTER** describes the time the data begins to be valid after the clock edge at the pin of the FPGA device.

- *clk_name* defines the fully hierarchical name of the input clock pad net.
- **REFERENCE_PIN**
 - Is an optional keyword that is most commonly used in source synchronous output interfaces where the clock is regenerated and sent with the data
 - Allows a bus skew analysis of the output signals relative to the **ref_pin** signal.

If **REFERENCE_PIN** is not specified, the bus skew report is referenced to the signal with the minimum clock to output delay.

- **RISING** | **FALLING**
 - Are optional keywords that define the transmitting clock edge of the synchronous elements sending the data
 - Automatically divide rising and falling edge registers in dual data rate (DDR) interfaces into separate groups for analysis

For more information about the **RISING** and **FALLING** keywords, see the *Timing Constraints User Guide*.

Output Group Method

When a group of output transmitted by the same clock have a shared timing requirement, the outputs can be grouped together to create a single timing constraint. The outputs can be grouped together by output signal names using pad groups, or by synchronous elements using register groups. By grouping separate signals together into a single time group, the memory and runtime of the implementation tools is reduced. In addition, the timing report will contain bus-based skew and clock centering information.

UCF Syntax Example

```
[TIMEGRP "pad_groupname"] OFFSET = OUT "offset_time" [units] {BEFORE|AFTER}
"clk_name"[REFERENCE_PIN "ref_pin"] [TIMEGRP "reg_groupname"] [{RISING |
FALLING}];
```

PCF Syntax Example

```
[TIMEGRP "pad_groupname"] OFFSET = OUT "offset_time" [units] {BEFORE|AFTER}
COMP "clk_iob_name"[REFERENCE_PIN "ref_pin"] [TIMEGRP "reg_groupname"]
[{RISING | FALLING}];
```

where

- The group specific method is identical to the general method with the additions noted below. For the definition of the other variables and keywords, see Global Method above.
- [TIMEGRP "*pad_groupname*"] is the optional output pad time group. This time group can be used to limit the scope of the OFFSET OUT constraint to only the synchronous elements feeding the output pad nets contained in the time group.
- [TIMEGRP "*reg_groupname*"] is the optional synchronous element time group. This time group can be used to limit the scope of the OFFSET OUT constraint to only the synchronous elements which transmit output data with the specified clock and are contained in the time group.

Net Specific Method

OFFSET OUT can also be used to specify an output constraint for a specific data net in a schematic, a specific output pad net in the UCF, or a specific output component in the PCF file.

Schematic Syntax When Attached to a Net Example

```
OFFSET = OUT "offset_time" [units] {BEFORE|AFTER} "clk_name" [TIMEGRP
"reg_groupname"] [REFERENCE_PIN "ref_pin"] [{RISING | FALLING}];
```

UCF Syntax

```
NET "pad_net_name" OFFSET = OUT "offset_time" [units] {BEFORE|AFTER} "clk_name"
[TIMEGRP "reg_groupname"] [REFERENCE_PIN "ref_pin"] [{RISING | FALLING}];
```

PCF Syntax

```
COMP "pad_net_name" OFFSET = OUT "offset_time" [units] {BEFORE|AFTER}
"clk_name" [TIMEGRP "reg_groupname"] [REFERENCE_PIN "ref_pin"] [{RISING
| FALLING}];
```

where:

- The group specific method is identical to the general method with the additions noted below. For the definition of the other variables and keywords, see *Global Method* above.
- "*pad_net_name*" is the name of the output data net attached to the pad.
- The PCF specification uses IO Blocks (COMPs) instead of NETs.
- If the IOB COMP name is omitted in the PCF, or the NET name is omitted in the UCF, the OFFSET OUT specification is assumed to be global.

UCF Source Synchronous DDR Example

The Source Synchronous Dual Data Rate (DDR) case consists of an interface where the clock is regenerated inside the FPGA and sent with the data to the capturing device. In a DDR interface, data is transmitted with both the rising and falling clock edges. In the DDR case, separate OFFSET OUT constraints must be defined for the rising and falling clock edge registers transmitting the data. The use of the **RISING** and **FALLING** keywords with the OFFSET OUT constraint simplifies this task. Also, for a bus skew analysis relative to the regenerated clock, the **REFERENCE_PIN** keyword is used.

In this example a clock signal called **clock** enters the FPGA. This clock signal triggers the data output synchronous elements. In addition, a regenerated clock called **TxClock** is created and sent along with the data. Because this is a source synchronous interface, the absolute clock to output time is not required, and the OFFSET OUT AFTER value is omitted to generate a report only constraint.

UCF Syntax

```
NET "clock" TNM_NET = CLK;  
TIMESPEC TS_CLK = PERIOD CLK 5.0 ns HIGH 50%;
```

```
OFFSET = OUT AFTER clock REFERENCE_PIN "TxClock" RISING;  
OFFSET = OUT AFTER clock REFERENCE_PIN "TxClock" FALLING;
```

UCF System Synchronous SDR Example

The System Synchronous Single Data Rate (SDR) case consists of an interface where the input clock is used to transmit the data to the receiving device. In the SDR interface, data is transmitted once per clock cycle. In this case a single OFFSET OUT requirement is needed to constrain the interface.

In this example a clock signal called **clock** enters the FPGA. This clock signal triggers the data output synchronous elements. Because this is a system synchronous interface, the absolute clock to output time is required to constrain the interface. In this case, a regenerated clock is not present, and the **REFERENCE_PIN** keyword is omitted to request the default skew reporting.

UCF Syntax

```
NET "clock" TNM_NET = CLK;  
TIMESPEC TS_CLK = PERIOD CLK 5.0 ns HIGH 50%;
```

```
OFFSET = OUT 5 ns AFTER "clock";
```

Schematic Syntax

- Attach to a specific net
- Attribute Name: **OFFSET**
- Attribute Values: **OUT** *offset_time* **BEFORE|AFTER** *clk_pad_netname*

XCF Syntax

The XCF syntax is the same as the UCF syntax. However, the XCF syntax supports only the OFFSET OUT AFTER method.

Constraints Editor Syntax

For information on Constraints Editor and Constraints Editor syntax in ISE® Design Suite, see the ISE Design Suite Help.

PlanAhead Syntax

For more information about using the PlanAhead software to create constraints, see *Floorplanning the Design* in the *PlanAhead User Guide (UG632)*. See [PlanAhead](#) in this Guide for information about:

- Defining placement constraints
- Assigning placement constraints
- Defining I/O pin configurations
- Floorplanning and placement constraints

Open Drain (OPEN_DRAIN)

CoolRunner™-II outputs can be configured to drive the primary macrocell output function as an open-drain output signal on the pin. Open Drain (OPEN_DRAIN) applies to non tristate (always active) outputs in the design. The output structure is configured as open-drain so that a one state on the output signal in the design produces a high-Z on the device pin instead of a driven High voltage.

The high-Z behavior associated with OPEN_DRAIN is not exhibited during functional simulation, but is represented accurately during post-fit timing simulation.

The logically-equivalent alternative to using OPEN_DRAIN is to take the original output-pad signal in the design and use it as a tristate disable for a constant-zero output data value. The CPLD Fitter automatically optimizes all tristate outputs with constant-zero data value in the design to take advantage of the open-drain capability of the device.

Architecture Support

Applies to CoolRunner™-II devices only.

Applicable Elements

- Output pads
- Pad nets

Propagation Rules

This constraint is a net or signal constraint. Any attachment to a macro, entity, or module is illegal.

Syntax Examples

The following examples show how to use this constraint with particular tools or methods. If a tool or method is not listed, you cannot use this constraint with it.

Schematic Syntax

- Attach to an output pad net
- Attribute Name
OPEN_DRAIN
- Attribute Values
 - TRUE
 - FALSE

VHDL Syntax

Declare the VHDL constraint as follows:

```
attribute OPEN_DRAIN: string;
```

Specify the VHDL constraint as follows:

```
attribute OPEN_DRAIN of signal_name : signal is "{TRUE|FALSE}";
```

For more information about basic VHDL syntax, see [VHDL Attributes](#).

Verilog Syntax

Place the Verilog constraint immediately before the module or instantiation.

Specify the Verilog constraint as follows:

```
(* OPEN_DRAIN = "{TRUE|FALSE}" *)
```

For more information about basic Verilog syntax, see [Verilog Attributes](#).

UCF and NCF Syntax

```
NET "mysignal" OPEN_DRAIN;
```

XCF Syntax

```
BEGIN MODEL "entity_name"  
NET "signal_name" OPEN_DRAIN=true;  
END;
```

OUT_TERM (Out Term)

The OUT_TERM (Out Term) constraint:

- Is a basic mapping constraint.
- Sets a configuration of output termination resistors

Out Term is valid:

- on an output pad NET
- on an output pad INST
- for the entire design

Architecture Support

Applies to FPGA devices. Does not apply to CPLD devices.

Applicable Elements

This constraint may be used with an FPGA device in one or more of the following design elements, or categories of design elements:

- IOB input components (such as IBUF)
- Output Pad Net

Not all devices support all elements. To see which design elements can be used with which devices, see the *Libraries Guides*. For more information, see the device [data sheet](#).

Propagation Rules

OUT_TERM is illegal when attached to a net or signal, except when the net or signal is connected to a pad. In this case, OUT_TERM is treated as attached to the pad instance.

Syntax Examples

The following examples show how to use this constraint with particular tools or methods. If a tool or method is not listed, you cannot use this constraint with it.

Values

- NONE
- TUNED
- UNTUNED_25
- UNTUNED_50
- UNTUNED_75

Schematic Syntax

- Attach to a pad net
- Attribute Name
OUT_TERM
- Attribute Values
See *Values* section above.

VHDL Syntax

Declare the VHDL constraint as follows:

Attribute OUT_TERM: string;

Specify the VHDL constraint as follows:

```
attribute OUT_TERM of signal_name: signal is  
"{NONE|TUNED|UNTUNED_25|UNTUNED_50|UNTUNED_75}";
```

For more information about basic VHDL syntax, see [VHDL Attributes](#).

Verilog Syntax

Place the Verilog constraint immediately before the module or instantiation.

Specify the Verilog constraint as follows:

```
(* OUT_TERM = "{NONE|TUNED|UNTUNED_25|UNTUNED_50|UNTUNED_75  
}" *)
```

For more information about basic Verilog syntax, see [Verilog Attributes](#).

UCF and NCF Syntax

The following statement configures the IO to use a PULLUP.

```
NET "pad_net_name"OUT_TERM = "{NONE|  
TUNED|UNTUNED_25|UNTUNED_50|UNTUNED_75}";
```

The following statement configures OUT_TERM to be used globally.

```
DEFAULT OUT_TERM = TUNED;
```

XCF Syntax

```
BEGIN MODEL "entity_name"  
NET "signal_name" out_term=tuned;  
END;
```

PlanAhead Syntax

For more information about using the PlanAhead software to create constraints, see *Floorplanning the Design* in the *PlanAhead User Guide (UG632)*. See [PlanAhead](#) in this Guide for information about:

- Defining placement constraints
- Assigning placement constraints
- Defining I/O pin configurations
- Floorplanning and placement constraints

PERIOD (Period)

PERIOD (Period) is a basic timing constraint and synthesis constraint. A clock period specification checks timing between all synchronous elements within the clock domain as defined in the destination element group. The group may contain paths that pass between clock domains if the clocks are defined as a function of one or the other.

Derived period constraints are defined in terms of the same units as their reference constraint.

The period specification is attached to the clock net. The definition of a clock period is unlike a FROM-TO style specification because the timing analysis tools automatically take into account any inversions of the clock net at register clock pins, lock phase, and includes all synchronous item types in the analysis. It also checks for hold violations.

A PERIOD constraint on the clock net in the following figure would generate a check for delays on all paths that terminate at a pin that has a setup or hold timing constraint relative to the clock net. This could include the data paths CLB1.Q to CLB2.D, as well as the path EN to CLB2.EC (if the enable were synchronous with respect to the clock).

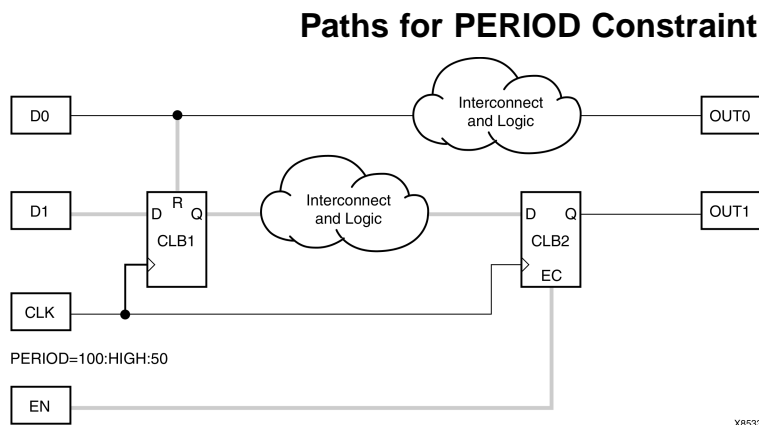

The timing tools do not check pad-to-register paths relative to setup requirements. For example, in the preceding figure, the path from D1 to Pin D of CLB1 is not included in the PERIOD constraint. The same is true for CLOCK_TO_OUT.

Special rules that apply when using [TNM](#) and [TNM_NET](#) with the PERIOD constraint for DLL, DCM, PLL, and MMCM are discussed below.

Architecture Support

Applies to FPGA devices. Does not apply to CPLD devices.

Applicable Elements

Applies to nets that feed forward to drive flip-flop clock pins.

Propagation Rules

Applies to the signal to which it is attached.

Syntax

The following examples show how to use this constraint with particular tools or methods. If a tool or method is not listed, you cannot use this constraint with it.

TIMESPEC PERIOD Method

The primary, recommended method for defining a clock period allows more complex derivative relationships to be defined as well as a simple clock period. The following constraint is defined using the **TIMESPEC** keyword in conjunction with a **TNM** constraint attached to the relevant clock net.

UCF Syntax

```
TIMESPEC "TSidentifier"=PERIOD "TNM_reference" period {HIGH | LOW}
[high_or_low_time] INPUT_JITTER value;
```

where

- *identifier* is a reference identifier that has a unique name
- *TNM_reference* identifies the group of elements to which the period constraint applies. This is typically the name of a **TNM_NET** that was attached to a clock net, but it can be any **TNM** group or user group (**TIMEGRP**) that contains only synchronous elements.

The following rules apply:

- The variable name *period* is the required clock period.
- The default units for *period* are nanoseconds, but the number can be followed by *ps*, *ns*, *micro*, or *ms*. The *period* can also be specified as a frequency value, using units of *MHz*, *GHz*, or *kHz*.
- Units may be entered with or without a leading space.
- Units are case-insensitive.
- The **HIGH|LOW** keyword indicates whether the first pulse in the period is high or low, and the optional *high_or_low_time* is the polarity of the first pulse. This defines the initial clock edge and is used in the **OFFSET** constraint. **HIGH** is the default logic level if the logic level is not specified.
- If an actual time is specified, it must be less than the period.
- If no *high_or_low_time* is specified the default duty cycle is 50%.
- The default units for *high_or_low_time* is *ns*, but the number can be followed by *%* or by *ps*, *ns*, *micro*, or *ms* to specify an actual time measurement.
- **INPUT_JITTER** is the random, peak-to-peak jitter on an input clock. The default units are picoseconds.

Examples

Clock net **sys_clk** has the constraint *tnm=master_clk* attached to it and the following constraint is attached to **TIMESPEC**.

UCF Syntax

```
TIMESPEC TS_master = PERIOD "master_clk" 50 HIGH 30 INPUT_JITTER 50;
```

This period constraint applies to the net **master_clk**, and defines a clock period of 50 nanoseconds, with an initial 30 nanosecond high time, and **INPUT_JITTER** at 50 ps.

```
TIMESPEC TS_clkinA = PERIOD "clkinA" 21 ns LOW 50% INPUT_JITTER 500
ps; TIMESPEC TS_clkinB = PERIOD "clkinB" 21 ns HIGH 50% INPUT_JITTER
500 ps;
```

NET PERIOD Method

Caution! This is a secondary method, and is not recommended.

Another method of defining a clock period is to attach the following constraint directly to a net in the path that drives the register clock pins.

Schematic Syntax

PERIOD = *period* {**HIGH**|**LOW**} [*high_or_low_time*] **INPUT_JITTER** *value*;

UCF Syntax

NET "*net_name*" **PERIOD** = *period* {**HIGH**|**LOW**} [*high_or_low_time*]
INPUT_JITTER *value*;

- *period* is the required clock period. The default units are nanoseconds, but the timing number can be followed by ps, ns, micro, or ms. The *period* can also be specified as a frequency value, using units of MHz, GHz, or kHz.
- Units may be entered with or without a leading space.
- Units are case-insensitive.
- The **HIGH**|**LOW** keyword indicates whether the first pulse in the period is high or low, and the optional *high_or_low_time* is the duty cycle of the first pulse. HIGH is the default logic level if the logic level is not specified.
- If an actual time is specified, it must be less than the period.
- If no high or low time is specified the default duty cycle is 50%.
- The default unit for *high_or_low_time* is ns, but the number can be followed by % or by ps, ns, micro or ms to specify an actual time measurement.

The PERIOD constraint is forward traced in exactly the same way a **TNM** would be and attaches itself to all of the synchronous elements that the forward tracing reaches. If a more complex form of tracing behavior is required (for example, where gated clocks are used in the design), you must place the PERIOD constraint on a particular net or use the preferred method described in the next section.

Specifying Derived Clocks

The preferred method of defining a clock period uses an identifier, allowing another clock period specification to reference it. Xilinx® recommends using the same **HIGH/LOW** keyword on the derived PERIOD constraints as the master PERIOD constraint. If the master PERIOD constraint has the **HIGH** keyword or is the default, Xilinx recommends using the same **HIGH** keyword on the derived PERIOD constraints. To define the relationship in the case of a derived clock, use the following syntax:

UCF Syntax

TIMESPEC "**TSidentifier**"=**PERIOD** "*timegroup_name*" "**TSidentifier**" [* or /] *factor*
PHASE [+ | -] *phase_value* [*units*];

where

- *identifier* is a reference identifier that has a unique name
- *factor* is a floating point number

Note You can omit the [* or /] factor if the specification being defined has the same value as the one being referenced (that is, they differ only in phase); this is the same as using "* 1".

- *phase_value* is a floating point number
- *units* are ps, ms, micro, or ns (default)

The following rules apply:

- If an actual time is specified it must be less than the period.
- If no *high_or_low_time* is specified, the default duty cycle is 50%.
- The default units for *high_or_low_time* is ns, but the number can be followed by % or by ps, ns, micro, or ms to specify an actual time measurement.

Examples of a Primary Clock with Derived Clocks

Period for primary clock:

TIMESPEC "TS01" = PERIOD "clk0" 10.0 ns;

Period for clock phase-shifted forward by 180 degrees:

TIMESPEC "TS02" = PERIOD "clk180" TS01 PHASE + 5.0 ns;

Period for clock phase-shifted backward by 90 degrees:

TIMESPEC "TS03" = PERIOD "clk90" TS01 PHASE - 2.5 ns;

Period for clock doubled and phase-shifted forward by 180 degrees (which is 90 degrees relative to TS01):

TIMESPEC "TS04" = PERIOD "clk180" TS01 / 2 PHASE + 2.5 ns;

Schematic Syntax

- Attach to a net. Following is an example of the syntax format.
- Attribute Name: **PERIOD**
- Attribute Values: *period [units] [{HIGH|LOW} [high_or_low_time [hi_lo_units]]*

VHDL Syntax

For XST, PERIOD applies only to a specific clock signal.

Note PERIOD constraints in the source code (VHDL or Verilog) will not propagate to the netlist.

Declare the VHDL constraint as follows:

attribute period: string;

Specify the VHDL constraint as follows:

attribute period of *signal_name* : signal is "*period [units]*";

where

- *period* is the required clock period
- *units* is an optional field to indicate the units for a clock period. The default is nanoseconds (ns), but the timing number can be followed by ps, ns, or micro to indicate the intended units.

For more information about basic VHDL syntax, see [VHDL Attributes](#).

Verilog Syntax

For XST, PERIOD applies only to a specific clock signal.

Note PERIOD constraints in the source code (VHDL or Verilog) will not propagate to the netlist.

Place the Verilog constraint immediately before the module or instantiation.

Specify the Verilog constraint as follows:

(* PERIOD = "*period [units]*" *)

- *period* is the required clock period
- *units* is an optional field to indicate the units for a clock period. The default is nanoseconds (ns), but the timing number can be followed by ps, ns, or micro to indicate the intended units.

For more information about basic Verilog syntax, see [Verilog Attributes](#).

UCF and NCF Syntax

Following are examples of UCF and NCF syntax.

- TIMESPEC PERIOD Method, Recommended
- NET PERIOD Method, Not Recommended

TIMESPEC PERIOD Method, Recommended

This is the primary, recommended method.

```
TIMESPEC "TSidentifier"=PERIOD "TNM_reference period" [units] [{HIGH | LOW}
[high_or_low_time [hi_lo_units]]] INPUT_JITTER value [units];
```

where

- *identifier* is a reference identifier that has a unique name
- *TNM_reference* is the identifier name that is attached to a clock net (or a net in the clock path) using the TNM or TNM_NET constraint

When a TNM_NET constraint is traced into the CLKIN input of a DLL, DCM, PLL, or MMCM component, new PERIOD specifications may be created at the DLL/DCM/PLL/MMCM outputs. If new PERIOD specifications are created, new TNM_NET groups to use in those specifications are also created.

Each new TNM_NET group is named the same as the corresponding DLL/DCM/PLL/MMCM output net (*outputnetname*). The new PERIOD specification becomes "*TS_outputnetname=PERIOD outputnetname value units.*"

The new TNM_NET groups are then traced forward from the DLL/DCM/PLL/MMCM output net to tag all synchronous elements controlled by that clock signal. The new groups and specifications are shown in the timing analysis reports.

The following rules apply:

- *period* is the required clock period.
- *units* is an optional field to indicate the units for a clock period. The default is nanoseconds (ns), but the timing number can be followed by ps, ms, micro, or % to indicate the intended units.
- HIGH or LOW indicates whether the first pulse is to be High or Low.
- *high_or_low_time* is the optional High or Low time, depending on the preceding keyword. If an actual time is specified, it must be less than the period. If no *high_or_low_time* is specified, the default duty cycle is 50 percent.
- *hi_lo_units* is an optional field to indicate the units for the duty cycle. The default is nanoseconds (ns), but the *high_or_low_time* number can be followed by ps, micro, ms, or % if the High or Low time is an actual time measurement.

The following statement assigns a clock period of 40 ns to the net named CLOCK, with the first pulse being High and having a duration of 25 nanoseconds.

```
NET "CLOCK" PERIOD=40 HIGH 25;
```

NET PERIOD Method, Not Recommended

Caution! This is a secondary method, and is not recommended.

```
NET "net_name" PERIOD=period [units] [{HIGH|LOW} [high_or_low_time [hi_lo_units]]];
```

where

- *period* is the required clock period
- *units* is an optional field to indicate the units for a clock period. The default is nanoseconds (ns), but the timing number can be followed by ps, ns, or micro to indicate the intended units.
- HIGH or LOW can be optionally specified to indicate whether the first pulse is to be High or Low.
- *hi_lo_units* can be ns (default), ps, or micro

The following rules apply:

- *high_or_low_time* is the optional High or Low time, depending on the preceding keyword.
- If an actual time is specified, it must be less than the period.
- If no *high_or_low_time* is specified, the default duty cycle is 50 percent.
- *hi_lo_units* is an optional field to indicate the units for the duty cycle.
- The default is nanoseconds (ns), but the *high_or_low_time* number can be followed by ps, micro, ms, or % if the High or Low time is an actual time measurement.

Constraints Editor Syntax

To open Constraints Editor:

1. In the ISE® Design Suite Processes window, double-click **Create Timing Constraint**.
2. In the **Constraint Type** list box under **Timing Constraints**, double-click **Clock Domains**.

XCF Syntax

XCF syntax is the same as UCF syntax

Both the simple and preferred are supported with the following limitation: HIGH/LOW values are not taken into account during timing estimation/optimization and only propagated to the final netlist if WRITE_TIMING_CONSTRAINTS = yes.

PCF Syntax

"TSidentifier"=PERIOD perioditem periodvalue INPUT_JITTER value;

where

- *perioditem* can be:
 - NET *name*
 - TIMEGRP *name*
- *periodvalue* can be:
 - TSidentifier PHASE [+ | -] *time*
 - TSidentifier PHASE *time*
 - TSidentifier PHASE [+ | -] *time* [LOW | HIGH] *time*
 - TSidentifier PHASE *time* [LOW | HIGH] *time*
 - TSidentifier PHASE [+ | -] *time* [LOW | HIGH] *percent*
 - TSidentifier PHASE *time* [LOW | HIGH] *percent*

PlanAhead Syntax

For more information about using the PlanAhead software to create constraints, see *Floorplanning the Design* in the *PlanAhead User Guide (UG632)*. See [PlanAhead](#) in this Guide for information about:

- Defining placement constraints
- Assigning placement constraints
- Defining I/O pin configurations
- Floorplanning and placement constraints

FPGA Editor Syntax

To set constraints, in the FPGA Editor main window, click Properties of Selected Items from the Edit menu. To set PERIOD constraint, click Properties of Selected Items from the Edit menu with a net selected. You can set the constraint from the Physical Constraints tab.

PERIOD Specifications on CLKDLLs, DCMs, PLLs, and MMCMs

When a [Timing Name \(TNM\)](#) or [Timing Name Net \(TNM_NET\)](#) property traces into an input pin on a DLL, DCM, PLL, or MMCM, it is handled as described in the following paragraphs.

The checking and transformations described are performed by the logical TimeSpec processing code, which is run during NGDBuild, or the translate process. (The checking timing specifications status message indicates that the logical TimeSpec processing is being run.) The modifications are saved in the built NGD, used by the Mapper and the Map phase passed through the PCF file to the Place and Route (PAR) phase and TRACE.

However, note that the data saved in the built NGD is distinct from the original TimeSpec user-applied properties, which are left unchanged by this process. Therefore, the Constraints Editor does not see these new groups or specifications, but sees (and possibly modifies) the original user-applied ones.

Conditions for Transformation

When a TNM_NET property is traced into the CLKIN pin of a DLL, DCM, PLL, or MMCM, the TNM group and its usage are examined. The TNM is pushed through the CLKDLL, DCM, PLL, or MMCM (as described below) only if the following conditions are met:

- The TNM group is used in exactly *one* PERIOD specification.
- The TNM group is *not* used in any FROM-TO or OFFSET specifications.
- The TNM group is *not* referenced in any user group definition.

If any of the above conditions are not met, the TNM is not be pushed through the CLKDLL/DCM/PLL/MMCM, and a warning message is issued. This does not prevent the TNM from tracing into other elements in the standard fashion, but if it traces nowhere else, and is used in a specification, an error results.

Definition of New PERIOD Specifications

If the CLK0 output on the CLKDLL, DCM, PLL, or MMCM is the only one being used (and neither CLKIN_DIVIDE_BY_2 nor CLKOUT_PHASE_SHIFT=FIXED are used), the original PERIOD specification is simply transferred to that clock output. Otherwise, for each clock output pin used on the CLKDLL, DCM, PLL, or MMCM, a new TNM group is created on the connected net, and a new PERIOD specification is created for that group. The following table shows how the new PERIOD specifications is defined, assuming an original PERIOD specification named TS_CLKIN.

New PERIOD Specifications

Output Pin	Period Value	Phase Shift	Duty Cycle
CLK0	$TS_CLKIN * 1$	none	Copied from TS_CLKIN if $DUTY_CYCLE_CORRECTION$ is FALSE. Otherwise, 50%
CLK90	$TS_CLKIN * 1$	$PHASE + (clk0_period * 1/4)$	Copied from TS_CLKIN if $DUTY_CYCLE_CORRECTION$ is FALSE. Otherwise, 50%
CLK180	$TS_CLKIN * 1$	$PHASE + (clk0_period * 1/2)$	Copied from TS_CLKIN if $DUTY_CYCLE_CORRECTION$ is FALSE. Otherwise, 50%
CLK270	$TS_CLKIN * 1$	$PHASE + (clk0_period * 3/4)$	Copied from TS_CLKIN if $DUTY_CYCLE_CORRECTION$ is FALSE. Otherwise, 50%
CLK2X	$TS_CLKIN / 2$	none	50%
CLK2X180	$TS_CLKIN / 2$	$PHASE + (clk2X_period * 1/2)$	50%
CLKDV	$TS_CLKIN * clkdv_divide$ where $clkdv_divide$ is the value of the $CLKDV_DIVIDE$ property (default 2.0)	none	50% except for non-integer divides in high-frequency mode (CLKDLLHF, or DCM with $DLL_FREQUENCY_MODE=HIGH$): CLKDV_DIVIDE 1.5 33.33% HIGH 2.5 40.00% HIGH 3.5 42.86% HIGH 4.5 44.44% HIGH 5.5 45.45% HIGH 6.5 46.15% HIGH 7.5 46.67% HIGH
CLKFX		none	
CLKFX180	$TS_CLKIN / clkfx_factor$ where $clkfx_factor$ is the value of the $CLKFX_MULTIPLY$ property (default 4.0) divided by the value of the $CLKFX_DIVIDE$ property (default 1.0).	$PHASE + (clkfx_period * 1/2)$	50%

The Period Value shown in this table assumes that the original specification, TS_CLKIN , is expressed as a time. If TS_CLKIN is expressed as a frequency, the multiply or divide operation is reversed.

If the DCM attribute $FIXED_PHASE_SHIFT$ or $VARIABLE_PHASE_SHIFT$ is used, the amount of phase specified is also included in the PHASE value.

PIN (Pin)

The PIN (Pin) User Constraints File (UCF) constraint:

- Defines a net location when used with [Location \(LOC\)](#).
- Is used in creating design flows.
- Is translated into a COMP/LOCATE constraint in the PCF file.

See *PCF Syntax* below.

Architecture Support

Applies to FPGA devices. Does not apply to CPLD devices.

Applicable Elements

Applies to nets.

Propagation Rules

Not applicable.

Syntax Examples

The following examples show how to use this constraint with particular tools or methods. If a tool or method is not listed, you cannot use this constraint with it.

UCF Syntax

```
PIN "module.pin " LOC=location ;
```

```
PIN mod.pin TIG;
```

PCF Syntax

```
COMP "name" LOCATE = SITE "location ";
```

This constraint specifies that the pseudo component that is created for the pin on the module should be located in the site location. Pseudo logic is created only when a net connects from a pin on one module to a pin on another module.

Post CRC (POST_CRC)

Post CRC (POST_CRC) enables or disables the configuration logic CRC error detection feature allowing for notification of any possible change to the configuration memory. For Spartan-3A devices, it also reserves the multi-use INIT pin for signaling of a configuration CRC failure. This also allows the banking rules used by PlanAhead™, PAR, and BitGen to refrain from using the IOB that drives the INIT pin. During configuration, the INIT pin operates as normal. After configuration, if POST_CRC analysis is enabled, the INIT pin serves as a CRC status pin. If comparison of the real-time computed CRC differs from the pre-computed CRC, a configuration memory change has been detected and the INIT pin is driven low.

For more information, see the device [data sheet](#).

Values for POST_CRC

Value	Description
ENABLE	Enables the Post CRC checking feature
DISABLE	Disables the Post CRC checking features (default)

Architecture Support

Applies to Virtex®-5, Virtex-6, Spartan®-3A, and Spartan-6 devices.

Applicable Elements

Applies to the entire design.

Propagation Rules

Applies to the entire design.

Syntax Examples

The following examples show how to use this constraint with particular tools or methods. If a tool or method is not listed, you cannot use this constraint with it.

UCF Syntax

```
CONFIG POST_CRC = {ENABLE|DISABLE|ONESHOT};
```

PCF Syntax

```
CONFIG POST_CRC = {ENABLE|DISABLE|ONESHOT};
```

Post CRC Action (POST_CRC_ACTION)

The Post CRC Action (POST_CRC_ACTION) constraint:

- Is a configuration logic CRC error detection mode supported for Spartan®-3A, Spartan-6, and Virtex®-6 devices only.
- Compares a pre-computed CRC for the configuration bitstream against a CRC computed by internal logic based on periodic readback of the configuration memory cells.
- Determines whether a CRC mismatch detection continues or whether the CRC operation is halted.
- Is applicable only when [POST_CRC](#) is set to **ENABLE**.

Architecture Support

Applies to the following devices:

- Spartan-3A
- Spartan-6
- Virtex-6

Applicable Elements

Applies to the entire device and is not specified on any particular design element.

Propagation Rules

Applies to the entire design or device.

Values

Value	Description
<i>HALT</i>	If a CRC mismatch is detected, cease reading back the bitstream, computing the comparison CRC, and making the comparison against the pre-computed CRC (Default for Spartan-6 devices).
<i>CONTINUE</i>	If a CRC mismatch is detected by the CRC comparison, continue reading back the bitstream, computing the comparison CRC, and making the comparison against the pre-computed CRC (Default for Virtex-6 devices).
<i>CORRECT_AND_CONTINUE</i>	If a CRC mismatch is detected by the CRC comparison, it is corrected and continues reading back the bitstream, computing the comparison CRC, and making the comparison against the pre-computed CRC.
<i>CORRECT_AND_HALT</i>	If a CRC mismatch is detected, it is corrected and ceases reading back the bitstream, computing the comparison CRC, and making the comparison against the pre-computed CRC.

Syntax Examples

The following examples show how to use this constraint with particular tools or methods. If a tool or method is not listed, you cannot use this constraint with it.

UCF Syntax

```
CONFIG POST_CRC_ACTION = [HALT|CONTINUE];
```

PCF Syntax

```
CONFIG POST_CRC_ACTION = [HALT|CONTINUE];
```

Post CRC Frequency (POST_CRC_FREQ)

The Post CRC Frequency (POST_CRC_FREQ) constraint:

- Is supported for the following devices only:
 - Spartan®-3A
 - Spartan-6
 - Virtex®-6
- Is a configuration logic CRC error detection mode.

A pre-computed CRC for the configuration bitstream is compared against a CRC computed by internal logic based on periodic readback of the configuration memory cells.

- Controls the frequency with which the configuration CRC check is performed for all devices that support this constraint.
- Is applicable only when POST_CRC is set to ENABLE.

	Frequency Range (MHz)	Steps (MHz)	Default Value (MHz)
Spartan-3A	1 to 100	1, 3, 6, 7, 8, 10, 12, 13, 17, 22, 25, 27, 33, 44, 50, 100	1
Spartan-6	1 to 100	1, 2, 4, 6, 10, 12, 16, 22, 26, 33, 40, 50, 66	1
Virtex-6	1 to 50	1, 2, 3, 6, 13, 25, 50	1

Architecture Support

Applies to Spartan®-3A, Spartan-6, and Virtex®-6 devices only.

Applicable Elements

Applies to the entire device and is not specified on any particular design element.

Propagation Rules

Applies to the entire design.

Syntax Examples

The following examples show how to use this constraint with particular tools or methods. If a tool or method is not listed, you cannot use this constraint with it.

UCF Syntax

```
CONFIG POST_CRC_FREQ = [1|3|6|7|8|10|12|13|17|22|25|27|33|44|50|100];
```

PCF Syntax

```
CONFIG POST_CRC_FREQ = [1|3|6|7|8|10|12|13|17|22|25|27|33|44|50|100];
```

Post CRC INIT Flag (POST_CRC_INIT_FLAG)

The Post CRC INIT Flag (POST_CRC_INIT_FLAG) constraint:

- Is a logic CRC error detection mode.
- Supports Virtex®-5 devices, Virtex-6 devices, and Spartan®-6 devices.
- Replaces POST_CRC_SIGNAL previously available for Virtex-5 device designs only.
- Is applicable only when POST_CRC is set to **enable**.

In logic CRC error detection mode, a pre-computed CRC for the configuration bitstream is compared against a CRC computed by internal logic based on periodic readback of the configuration memory cells. POST_CRC_INIT_FLAG determines whether the **INIT_B** pin is enabled as an output for the **SEU (Single Event Upset)** error signal.

Spartan-6 devices do not have a **FRAME_ECC** site, so the **INIT_B** pin is the only potential source for the CRC error signal. For Virtex-5 devices and Virtex-6 devices, the error condition is always available from the **FRAME_ECC_VIRTEX5** and **FRAME_ECC_VIRTEX6** sites.

Values for POST_CRC_INIT_FLAG

Value	Description
DISABLE	<p>Virtex-5 devices and Virtex-6 devices</p> <p>Disables the use of the INIT_B pin, with the FRAME_ECC site as the sole source of the CRC error signal.</p> <p>Spartan-6 devices</p> <p>Does not have FRAME_ECC so the INIT status flag is turned off.</p>
ENABLE	<p>Leaves the INIT_B pin enabled as a source of the CRC error signal.</p> <p>ENABLE is the default.</p>

Architecture Support

Applies to Virtex®-5, Virtex-6, and Spartan®-6 devices only.

Applicable Elements

Applies to the entire device and is not specified on any particular design element.

Propagation Rules

Applies to the entire design or device.

Syntax Examples

The following examples show how to use this constraint with particular tools or methods. If a tool or method is not listed, you cannot use this constraint with it.

UCF Syntax

```
CONFIG POST_CRC_INIT_FLAG = [DISABLE|ENABLE];
```

PCF Syntax

```
CONFIG POST_CRC_INIT_FLAG = [DISABLE|ENABLE];
```

Post CRC Signal (POST_CRC_SIGNAL)

Virtex®-5 devices support a configuration logic CRC error detection mode called Post CRC Signal (POST_CRC_SIGNAL). In this mode, a pre-computed CRC for the configuration bitstream is compared against a CRC computed by internal logic based on periodic readback of the configuration memory cells. POST_CRC_SIGNAL determines whether the INIT_B pin is enabled as an output for the SEU (Single Event Upset) error signal. The error condition is still available from the FRAME_ECC_VIRTEX5 site. This constraint is only applicable when POST_CRC is set to ENABLE.

Values for POST_CRC_SIGNAL

Value	Description
FRAME_ECC_ONLY	Disables the use of the INIT_B pin, with the FRAME_ECC site as the sole source of the CRC error signal
INIT_AND_FRAME_ECC	Leaves the INIT_B pin enabled as a source of the CRC error signal (default)

Architecture Support

Applies to Virtex®-5 devices only.

Applicable Elements

Applies to the entire device and is not specified on any particular design element.

Propagation Rules

Applies to the entire design.

Syntax Examples

The following examples show how to use this constraint with particular tools or methods. If a tool or method is not listed, you cannot use this constraint with it.

UCF Syntax

```
CONFIG POST_CRC_SIGNAL = [FRAME_ECC_ONLY|INIT_AND_FRAME_ECC];
```

PCF Syntax

```
CONFIG POST_CRC_SIGNAL = [FRAME_ECC_ONLY|INIT_AND_FRAME_ECC];
```

Post CRC Source (POST_CRC_SOURCE)

Post CRC Source (POST_CRC_SOURCE) specifies the source of the CRC value when the configuration logic CRC error detection feature is used for notification of any possible change to the configuration memory.

Architecture Support

Applies to Virtex®-5, Virtex-6, and Spartan®-6 devices.

Applicable Elements

Applies to the entire design.

Propagation Rules

Applies to the entire design.

Syntax Examples

The following examples show how to use this constraint with particular tools or methods. If a tool or method is not listed, you cannot use this constraint with it.

Values

- **PRE_COMPUTED**
A pre-computed bitstream CRC will be used.
- **FIRST_READBACK**
The first computed CRC will be used.

UCF and NCF Syntax

```
CONFIG POST_CRC_SOURCE = {PRE_COMPUTED|FIRST_READBACK};
```

PCF Syntax

Same as *UCF and NCF Syntax* above.

PRIORITY (Priority)

The PRIORITY (Priority) constraint:

- Is an advanced timing constraint.
- Is used in situations where there is a conflict between two timing constraints that cover the same path.

The lower the PRIORITY value, the higher the priority. This value does not affect which paths are placed and routed first. It affects only which constraint controls the path when two constraints of equal priority cover the same path.

Architecture Support

Applies to all FPGA devices and all CPLD devices.

Applicable Elements

[Timing Specifications \(TIMESPEC\)](#)

Propagation Rules

Not applicable.

Values

Every timing constraint has a priority of 0 as soon as it is written in the UCF. If a timing constraint is to take precedence over every other constraint, a negative number is required behind the PRIORITY keyword.

Syntax Examples

The following examples show how to use this constraint with particular tools or methods. If a tool or method is not listed, you cannot use this constraint with it.

UCF and NCF Syntax

```
normal_timespec_syntax PRIORITY integer ;
```

where

- *normal_timespec_syntax* is a legal timing specification
- *integer* represents the priority (the smaller the number, the higher the priority)

The number can be positive, negative, or zero. The value has meaning only when compared with other PRIORITY values. The lower the value, the higher the priority.

```
TIMESPEC "TS01"=FROM "GROUPA" TO "GROUPB" 40 PRIORITY 4;
```

The constraint with a PRIORITY keyword always has a higher priority than the one without it.

PCF Syntax

Same as *UCF and NCF Syntax* above.

PROHIBIT (Prohibit)

The PROHIBIT (Prohibit) constraint:

- Is a basic placement constraint.
- Disallows the use of a site within PAR, FPGA Editor, and the CPLD fitter.

For an FPGA device, use the following location types to define the physical location of an element.

Location Types for FPGA Devices

Element Type	Location Specification	Meaning
IOB	P12	IOB location (chip carrier)
	A12	IOB location (pin grid)
	T, B, L, R	Applies to IOBs and indicates edge locations (bottom, left, top, right) for Spartan®-3, Spartan-3A, Spartan-3E, Virtex®-4 and Virtex-5 devices
	LB, RB, LT, RT, BR, TR, BL, TL	Applies to IOBs and indicates half edges (for example, left bottom, right bottom) for Spartan-3, Spartan-3A, Spartan-3E, Virtex-4 and Virtex-5 devices
	Bank 0, Bank 1, Bank 2, Bank 3, Bank 4, Bank 5, Bank 6, Bank 7	Applies to IOBs and indicates half edges (banks) for Spartan-3, Spartan-3A, Spartan-3E, Virtex-4 and Virtex-5 devices
Slice	SLICE_X22Y3	Slice location for Spartan-3, Spartan-3A, Spartan-3E, Virtex-4 and Virtex-5 devices
block RAM	RAMB16_X2Y56	Block RAM location for Spartan-3, Spartan-3A, Spartan-3E, Virtex-4 and Virtex-5 devices
Multiplier	MULT18X18_X55Y82	Multiplier location for Spartan-3, Spartan-3A, Spartan-3E, Virtex-4 and Virtex-5 devices
Global Clock	BUFGMUX0P	Global clock buffer location for Spartan-3, Spartan-3A, Spartan-3E, Virtex-4 and Virtex-5 devices
Digital Clock Manager (DCM)	DCM_X[A]Y[B]	Digital Clock Manager for Spartan-3, Spartan-3A, Spartan-3E, Virtex-4 and Virtex-5 devices
Phase Lock Loop (PLL)	PLL_X[A]Y[B]	Phase Lock Loop for Spartan-3, Spartan-3A, Spartan-3E, Virtex-4 and Virtex-5 devices
Mixed-Mode Clock Manager (MMCM)	MMCM_X[A]Y[B]	Mixed-Mode Clock Manager for Virtex-6

You can use the wildcard character (*) to replace a single location with a range as shown in the following example.

```
SLICE_X*Y5
```

Any slice of an FPGA device whose Y-coordinate is 5

The following are *not* supported:

- Dot extensions on ranges. For example, `LOC=SLICE_X3Y5:SLICE_X5Y7.G`
- The wildcard character for Spartan-3, Spartan-3A, Spartan-3E, Virtex-4 and Virtex-5 global buffers or DLL locations.

Location Types for CPLD Devices

CPLD devices support only the location type *pin_name*

where

pin_name is *Pnn* for numeric pin names or *rc* for row-column pin names

Architecture Support

Applies to all FPGA devices and all CPLD devices.

Applicable Elements

Sites

Propagation Rules

It is illegal to attach PROHIBIT to a net, signal, entity, module, or macro.

Syntax Examples

The following examples show how to use this constraint with particular tools or methods. If a tool or method is not listed, you cannot use this constraint with it.

UCF Syntax

In a UCF file, PROHIBIT must be preceded by the keyword CONFIG.

For a single location:

```
CONFIG PROHIBIT=location;
```

For multiple single locations

```
CONFIG PROHIBIT=location1, location2, ... ,locationn;
```

For a range of locations:

```
CONFIG PROHIBIT=location1:location2;where
```

location is a legal location type for the part type

For more information, see *Location Types for FPGA Devices and Location Types for CPLD Devices* below. For examples of using the location types, see the [Location \(LOC\)](#) constraint. CPLD devices do not support the "Range of locations" form of PROHIBIT.

The following statement prohibits use of the site P45.

```
CONFIG PROHIBIT=P45;
```

The following statement prohibits use of the slice at the SLICE_X6Y8 site.

```
CONFIG PROHIBIT=SLICE_X6Y8;
```

PCF Syntax

For single or multiple single locations:

```
COMP "comp_name" PROHIBIT = [SOFT] "site_group"..."site_group";
```

```
COMPGRP "group_name" PROHIBIT = [SOFT] "site_group"..."site_group";
```

```
MACRO "name" PROHIBIT = [SOFT] "site_group"..."site_group";
```

For a range of locations:

```
COMP "comp_name" PROHIBIT = [SOFT] "site_group"..."site_group";
```

```
COMPGRP "group_name" PROHIBIT = [SOFT] "site_group"..."site_group";
```

```
MACRO "name" PROHIBIT = [SOFT] "site_group"..."site_group";
```

where

- *site_group* is one of the following:
 - **SITE** "*site_name*"
 - **SITEGRP** "*site_group_name*"
- *site_name* is a component site (that is, a CLB or IOB location).

PlanAhead™ Syntax

For more information about using the PlanAhead software to create constraints, see *Floorplanning the Design* in the *PlanAhead User Guide* (UG632). See [PlanAhead](#) in this Guide for information about:

- Defining placement constraints
- Assigning placement constraints
- Defining I/O pin configurations
- Floorplanning and placement constraints

Pinout and Area Constraints Editor (PACE) Syntax

Pinout and Area Constraints Editor (PACE) can be used to set PROHIBIT. For more information, see the Prohibit Mode command section in the PACE Help.

Note PACE is supported for CPLD devices only.

FPGA Editor Syntax

FPGA Editor supports PROHIBIT. The constraint is written to the Physical Constraints File (PCF) by the Editor. For more information, see the Prohibit Constraint topic in the FPGA Editor Help.

PULLDOWN (Pulldown)

The PULLDOWN (Pulldown) constraint:

- Is a basic mapping constraint.
- Guarantees a logic Low level to allow tri-stated nets to avoid floating when not being driven.

KEEPER, PULLUP, and PULLDOWN are valid only on pad NETs, not on INSTs of any kind.

Architecture Support

Applies to all FPGA devices and the CoolRunner™-II CPLD device only.

Applicable Elements

- Input
- Tristate outputs
- Bidirectional pad nets

Propagation Rules

This constraint is a net constraint. Any attachment to a design element is illegal.

Syntax Examples

The following examples show how to use this constraint with particular tools or methods. If a tool or method is not listed, you cannot use this constraint with it.

Schematic Syntax

- Attach to a pad net
- Attribute Name
PULLDOWN
- Attribute Values
TRUE
FALSE

VHDL Syntax

Declare the VHDL constraint as follows:

```
attribute PULLDOWN: string;
```

Specify the VHDL constraint as follows:

```
attribute PULLDOWN of signal_name: signal is "{YES|NO|TRUE|FALSE}";
```

For more information about basic VHDL syntax, see [VHDL Attributes](#).

Verilog Syntax

Place the Verilog constraint immediately before the module or instantiation.

Specify the Verilog constraint as follows:

```
(* PULLDOWN = "{YES|NO|TRUE|FALSE}" *)
```

For more information about basic Verilog syntax, see [Verilog Attributes](#).

UCF and NCF Syntax

The following statement configures the IO to use a PULLDOWN.

```
NET "pad_net_name" PULLDOWN;
```

The following statement configures PULLDOWN to be used globally.

```
DEFAULT PULLDOWN = TRUE;
```

XCF Syntax

```
BEGIN MODEL "entity_name"
```

```
NET "signal_name" pulldown=true;
```

```
END;
```

PlanAhead™ Syntax

For more information about using the PlanAhead software to create constraints, see *Floorplanning the Design* in the *PlanAhead User Guide (UG632)*. See [PlanAhead](#) in this Guide for information about:

- Defining placement constraints
- Assigning placement constraints
- Defining I/O pin configurations
- Floorplanning and placement constraints

PULLUP (Pullup)

The PULLUP (Pullup) constraint:

- Is a basic mapping constraint.
- Guarantees a logic High level to allow tri-stated nets to avoid floating when not being driven.

KEEPER, PULLUP, and PULLDOWN are only valid on pad NET, not on INST of any kind.

For CoolRunner™-II designs, KEEPER and PULLUP are mutually exclusive across the whole device.

NGDBUILD ignores the following:

- DEFAULT KEEPER = FALSE
- DEFAULT PULLUP = FALSE
- DEFAULT PULLDOWN = FALSE

Architecture Support

Applies to all FPGA devices and the CoolRunner™ XPLA3 and CoolRunner-II CPLD devices.

Applicable Elements

- Input
- Tristate outputs
- Bidirectional pad nets

Propagation Rules

This constraint is a net constraint. Any attachment to a design element is illegal.

Syntax Examples

The following examples show how to use this constraint with particular tools or methods. If a tool or method is not listed, you cannot use this constraint with it.

Schematic Syntax

- Attach to a pad net
- Attribute Name
PULLUP
- Attribute Values
TRUE
FALSE

VHDL Syntax

Declare the VHDL constraint as follows:

```
attribute PULLUP: string;
```

Specify the VHDL constraint as follows:

```
attribute PULLUP of signal_name: signal is "{YES|NO|TRUE|FALSE}";
```

For more information about basic VHDL syntax, see [VHDL Attributes](#).

Verilog Syntax

Place the Verilog constraint immediately before the module or instantiation.

Specify the Verilog constraint as follows:

```
(* PULLUP = "{YES|NO|TRUE|FALSE}" *)
```

For more information about basic Verilog syntax, see [Verilog Attributes](#).

UCF and NCF Syntax

The following statement configures the IO to use a PULLUP.

```
NET "pad_net_name" PULLUP;
```

The following statement configures PULLUP to be used globally.

```
DEFAULT PULLUP = TRUE;
```

XCF Syntax

```
BEGIN MODEL "entity_name"
```

```
NET "signal_name" pullup=true;
```

```
END;
```

PlanAhead™ Syntax

For more information about using the PlanAhead software to create constraints, see *Floorplanning the Design* in the *PlanAhead User Guide (UG632)*. See [PlanAhead](#) in this Guide for information about:

- Defining placement constraints
- Assigning placement constraints
- Defining I/O pin configurations
- Floorplanning and placement constraints

PWR_MODE (Power Mode)

The PWR_MODE (Power Mode) constraint:

- Is an advanced fitter constraint.
- Defines the mode, Low power, or High performance (standard power), of the macrocell that implements the tagged element

If the tagged function is collapsed forward into its fanouts, PWR_MODE is not applied.

Architecture Support

Applies to XC9500 devices only.

Applicable Elements

- Nets
- Any instance

Propagation Rules

When attached to a net, attaches to all applicable elements that drive the net.

When attached to a design element, propagates to all applicable elements in the hierarchy within the design element.

Syntax Examples

The following examples show how to use this constraint with particular tools or methods. If a tool or method is not listed, you cannot use this constraint with it.

Schematic Syntax

- Attach to a net or an instance
- Attribute Name
PWR_MODE
- Attribute Values
 - **LOW**
 - **STD**

VHDL Syntax

Declare the VHDL constraint as follows:

```
attribute PWR_MODE: string;
```

Specify the VHDL constraint as follows:

```
attribute PWR_MODE of {signal_name|component_name|label_name}:  
{signal|component|label} is "{LOW|STD}";
```

For more information about basic VHDL syntax, see [VHDL Attributes](#).

Verilog Syntax

Place the Verilog constraint immediately before the module or instantiation.

Specify the Verilog constraint as follows:

```
(* PWR_MODE = "{LOW|STD} *)
```

For more information about basic Verilog syntax, see [Verilog Attributes](#).

UCF and NCF Syntax

The following statement specifies that the macrocell that implements the net `$$SIG_0` is in **Low** power mode.

```
NET "$1187/$SIG_0" PWR_MODE=LOW;
```

XCF Syntax

```
BEGIN MODEL "entity_name"  
NET "signal_name" PWR_MODE={LOW|STD};  
INST "instance_name" PWR_MODE={LOW|STD};  
END;
```

REG (Registers)

The REG (Registers) constraint:

- Is a basic fitter constraint.
- Specifies how a register is to be implemented in the CPLD macrocell.
- Has the following values:

- **CE**

When applied to a flip-flop primitive with a **CE** input, **CE** forces the **CE** input to be implemented using a clock enable product term in the macrocell. Normally the fitter uses the register **CE** input only if all logic on the **CE** input can be implemented using the single **CE** product term. Otherwise the fitter decomposes the **CE** input into the D (or T) logic expression unless **REG=CE** is applied. **CE** product terms are not available in XC9500 devices (**REG=CE** is ignored). In XC9500XL devices, the **CE** product term is available only for registers that do not use both the **CLR** and **PRE** inputs.

- **TFF**

Indicates that the register is to be implemented as a T-type flip-flop in the CPLD macrocell. If applied to a D-flip-flop primitive, the D-input expression is transformed to T-input form and implemented with a T-flip-flop. Automatic transformation between D and T flip-flops is normally performed by the CPLD fitter.

Architecture Support

Applies to CPLD devices only. Does not apply to FPGA devices.

Applicable Elements

Applies to registers.

Propagation Rules

When attached to a design element, propagates to all applicable elements in the hierarchy within the design element.

Syntax Examples

The following examples show how to use this constraint with particular tools or methods. If a tool or method is not listed, you cannot use this constraint with it.

Schematic Syntax

- Attach to a flip-flop instance or macro containing flip-flops
- Attribute Name

REG

VHDL Syntax

Declare the VHDL constraint as follows:

attribute REG: string;

Specify the VHDL constraint as follows:

attribute REG of *signal_name*: signal is "{CE|TFF}";

For more information on **CE** and **TFF**, see the *UCF and NCF Syntax* below.

For more information about basic VHDL syntax, see [VHDL Attributes](#).

Verilog Syntax

Place the Verilog constraint immediately before the module or instantiation.

Specify the Verilog constraint as follows:

```
(* REG = {CE|TFF} *)
```

For more information about basic Verilog syntax, see [Verilog Attributes](#).

UCF and NCF Syntax

```
INST "instance_name" REG = {CE | TFF};
```

The following statement specifies that the CE pin input be implemented using the clock enable product term of the XC9500XL macrocell.

```
INST "Q1" REG=CE;
```

XCF Syntax

```
BEGIN MODEL "entity_name"
```

```
NET "signal_name" REG={CE|TFF};
```

```
END;
```

RLOC (Relative Location)

The Relative Location (RLOC) constraint:

- Is a basic mapping and placement constraint.
- Is a synthesis constraint.
- Groups logic elements into discrete sets and allows you to define the location of any element within the set relative to other elements in the set, regardless of eventual placement in the overall design.
- Allows you to place logic blocks relative to each other to increase speed and use die resources efficiently.
- Provides an order and structure to related design elements without requiring you to specify their absolute placement on the FPGA die.
- Allows you to replace any existing hard macro with an equivalent that can be directly simulated.

Two coordinate systems can be used when defining RLOC constraints for all FPGA architectures:

- Original grid system
Does NOT use a universal coordinate system for all component types
- New RPM grid system
DOES use a universal coordinate system for all component types

Therefore, with the RPM grid system, you can create a relocatable RPM macro containing different types of components, such as Block RAM and slice components.

In the Unified Libraries, you can use RLOC constraints with **BUFT** and **CLB** related primitives, that is, **FMAP**. You can also use them on non-primitive macro symbols. There are some restrictions on the use of RLOC constraints on **BUFT** symbols. For more information, see *Set Modifiers* below. You cannot use RLOC constraints with decoders or clocks. You can use LOC constraints on all primitives:

- BUFT
- CLB
- CLB
- decoder
- clock

Although RLOC constraints control the relative placement of logic blocks, they do not guarantee that the same routing resources are used to connect the logic blocks from implementation to implementation. In order to control the routing used, see the [DIRECTED_ROUTING](#) constraint.

Architecture Support

Applies to FPGA devices. Does not apply to CPLD devices.

Applicable Elements

For the design elements that can be used with particular device families, see the *Libraries Guides*. For more information, see the device [data sheet](#).

- Registers
- ROM
- RAMS, RAMD
- BUFT

Can be used only if the associated RPM has an RLOC_ORIGIN that causes the RLOC values in the RPM to be changed to LOC values.

- LUT, MUXF5, MUXF6, MUXCY, XORCY, MULT_AND, SRL16, SRL16E, MUXF7 (Spartan®-3, Spartan-3A, Spartan-3E devices only)
- MUXF8 (all FPGA devices only)
- Block RAMs
- Multipliers
- DSP48

Propagation Rules

RLOC is a design element constraint and any attachment to a net is illegal. When attached to a design element, RLOC propagates to all applicable elements in the hierarchy within the design element.

NGDBuild continues to propagate LOC constraints down the design hierarchy. It adds this constraint to appropriate objects that are not members of a set. While RLOC constraint propagation is limited to sets, the LOC constraint is applied from its start point all the way down the hierarchy.

When the design is flattened, the row and column numbers of an RLOC constraint on an element are added to the row and column numbers of the RLOC constraints of the set members below it in the hierarchy. This feature gives you the ability to modify existing RLOC values in submodules and macros without changing the previously assigned RLOC values on the primitive symbols.

Constraint Syntax

The RLOC constraint is specified using the slice-based XY coordinate system.

RLOC=XmYn

where

- *m* is an integer representing the X coordinate
- *n* is an integer representing the Y coordinate

Using RPM Grid

While Relative Location constraints are applied to symbols in the logical design in the same way as a standard RPM, the grid values are different. The RPM Grid coordinates are determined by selecting the site in question in FPGA Editor and reading the grid coordinates in the history window. For example, selecting the lower leftmost slice site results in the following:

```
site "SLICE_X0Y0", type = SLICE (RPM grid X3Y4)
```

Slice X0Y0 in the original grid system is now shown as X3Y4 in the RPM Grid system. Any symbols intended for this slice should have the following constraint applied:

RLOC = X3Y4

FPGA Editor should generally be used to look up grid values for a specific device. In addition to the RLOC constraints, one symbol in the macro must have the following constraint applied:

RPM_GRID = GRID

Not all synthesis tools recognize and pass the RPM_GRID attribute. You may need to assign this attribute using the User Constraints File (UCF) constraint.

INST "*instance_name*" RPM_GRID = GRID

where

instance_name is the full hierarchical path to the symbol name.

Set Modifiers

A modifier modifies the RLOC constraints associated with design elements. Since it modifies the RLOC constraints of all the members of a set, it must be applied in a way that propagates it to all the members of the set easily and intuitively. For this reason, the RLOC modifiers of a set are placed at the start of the set. The following set modifiers apply to RLOC constraints.

- **RLOC** modifies the values of other RLOC constraints below the element in the hierarchy of the set

Regardless of the set type, RLOC values (row, column, extension or **XY** values) on an element always propagate down the hierarchy and are added at lower levels of the hierarchy to RLOC constraints on elements in the same set.

- **RLOC_ORIGIN (Relative Location Origin)** sets the exact die location of the set members. This constraint lets you change the RLOC values into absolute LOC constraints that respect the structure of the set.

The design resolution program (NGCBuild) translates the **RLOC_ORIGIN** constraint into **LOC** constraints. The row and column values of the **RLOC_ORIGIN** are added individually to the members of the set after all RLOC modifications have been made to their row and column values by addition through the hierarchy. The final values are then turned into LOC constraints on individual primitives.

- **RLOC_RANGE (Relative Location Range)** limits the members of a set to a certain range on the die.

In this case, the set could “float” as a unit within the range until a final placement. Since every member of the set must fit within the range, it is important that you specify a range that defines an area large enough to respect the spatial structure of the set.

You cannot use **RLOC_RANGE** on sets that include BUFT symbols.

- **USE_RLOC (Use Relative Location)** turns the RLOC constraints on and off for a specific element or section of a set. **USE_RLOC** can be either **TRUE** or **FALSE**.

The application of **USE_RLOC** is strictly based on hierarchy. A **USE_RLOC** constraint attached to an element applies to all its underlying elements that are members of the same set. If it is attached to a symbol that defines the start of a set, the constraint is applied to all the underlying member elements, which represent the entire set.

When **USE_RLOC=FALSE** is applied, the RLOC and set constraints are removed from the affected symbols in the NCD file. This process is different than that followed for the **RLOC_ORIGIN** constraint. For **RLOC_ORIGIN**, the mapper generates and outputs a **LOC** constraint in addition to all the set and RLOC constraints in the PCF file. The mapper does not retain the original constraints in the presence of **USE_RLOC=FALSE** because these cannot be turned on again in later programs.

You can attach **USE_RLOC** directly to a primitive symbol so that it affects only that symbol.

Linking Sets

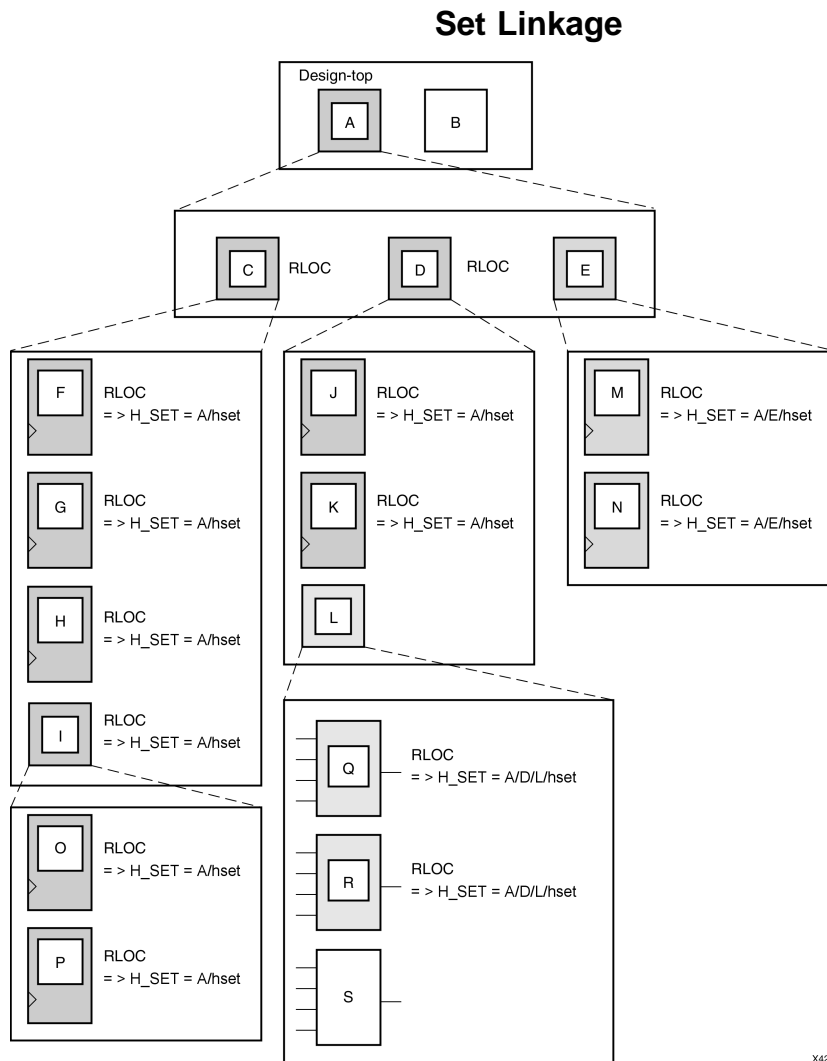

This example shows the process of linking together elements through the design hierarchy. The complete RLOC specification, $RLOC=R\ mCn$ or $RLOC=\chi mXn$, is required for a real design.

Note In this and other illustrations in this section, the sets are shaded differently to distinguish one set from another.

All design elements with RLOC constraints at a single node of the design hierarchy are considered to be in the same **H_SET** set unless they are assigned another type of set constraint, an **RLOC_ORIGIN** constraint, or an **RLOC_RANGE** constraint. In this figure, RLOC constraints have been added on primitives and non-primitives C, D, F, G, H, I, J, K, M, N, O, P, Q, and R. No RLOC constraints were placed on B, E, L, or . Macros C and D have an RLOC constraint at node A, so all the primitives below C and D that have RLOCs are members of a single **H_SET** set.

The name of this **H_SET** set is **A/h_set** because it is at node A that the set starts. The start of an **H_SET** set is the lowest common ancestor of all the RLOC-tagged constraints that constitute the elements of that **H_SET** set.

Because element E does not have an RLOC constraint, it is not linked to the **A/h_set** set. The RLOC-tagged elements M and N, which lie below element E, are therefore in their own **H_SET** set. The start of that **H_SET** set is **A/E**, giving it the name **A/E/h_set**.

Similarly, the **Q** and **R** primitives are in their own **H_SET** set because they are not linked through element **L** to any other design elements. The lowest common ancestor for their **H_SET** set is **L**, which gives it the name **A/D/L/h_set**. After the flattening, NGDBuild attaches the sets to the primitives shown in the following table.

Set	Primitives
H_SET=A/h_set	F, G, H, O, P, J, K
H_SET=A/D/L/h_set	Q, R
H_SET=A/E/h_set	N

Consider a situation in which a set is created at the top of the design. There is no lowest common ancestor if macro **A** also has an RLOC constraint, since **A** is at the top of the design and has no ancestor. In this case, the base name **h_set** has no hierarchically qualified prefix, and the name of the **H_SET** set is simply **h_set**.

Modifying Sets

The RLOC constraint assigns a primitive an RLOC value (the row and column numbers with the optional extensions), specifies its membership in a set, and links together elements at different levels of the hierarchy. In the *Three H_SET Sets* example, the RLOC constraint on macros **C** and **D** links together all the objects with RLOC constraints below them. An RLOC constraint is also used to modify the RLOC values of constraints below it in the hierarchy. In other words, RLOC values of elements affect the RLOC values of all other member elements of the same **H_SET** set that lie below the given element in the design hierarchy.

When the design is flattened, the **XY** values of an RLOC constraint on an element are added to the **XY** values of the RLOC constraints of the set members below it in the hierarchy. This feature allows you to modify existing RLOC values in submodules and macros without changing the previously assigned RLOC values on the primitive symbols.

The following sections describe the effect of the hierarchy on set modification.

Adding RLOC Values Down the Hierarchy Example (Slice-Based XY Designations)

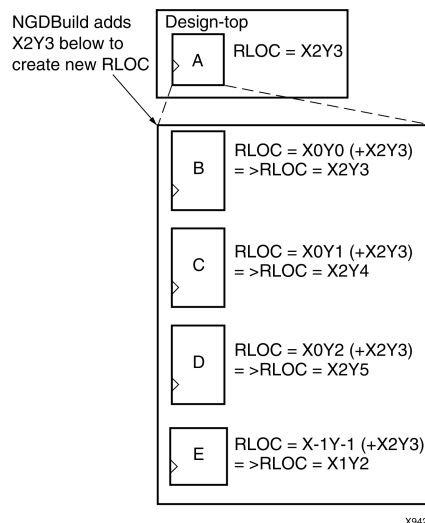

This example illustrates the process of adding RLOC values down the hierarchy. The row and column values between the parentheses show the addition function performed

by the mapper. The italicized text prefixed by => is added by MAP during the design resolution process and replaces the original RLOC constraint that you added.

Modifying RLOC Values of Same Macro and Linking Together as One Set

The ability to modify RLOC values down the hierarchy is particularly valuable when instantiating the same macro more than once. Typically, macros are designed with RLOC constraints that are modified when the macro is instantiated.

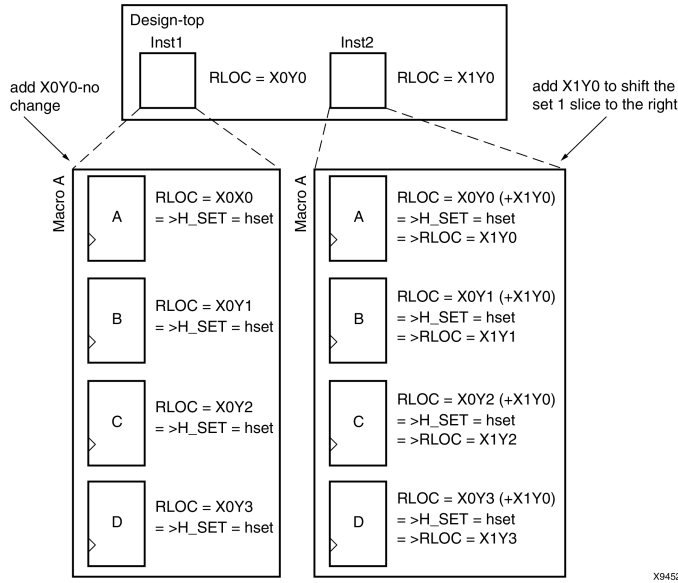

This example is a variation of the previous example. The RLOC constraint on **Inst1** and **Inst2** now link all the objects in one **H_SET** set.

Because the **RLOC=X0Y0** modifier on the **Inst1** macro does not affect the objects below it, the mapper adds only the **H_SET** tag to the objects and leaves the RLOC values as they are. However, the **RLOC=X1Y0** modifier on the **Inst2** macro causes MAP to change the RLOC values on objects below it, as well as to add the **H_SET** tag, as shown in the italicized text.

Separating Elements from H_SET Sets

The **HU_SET** (HU Set) constraint is a variation of the implicit **H_SET** (hierarchy set). **HU_SET** defines the start of a new set. Like **H_SET**, **HU_SET** is defined by the design hierarchy. However, you can use **HU_SET** to assign a user-defined name to the **HU_SET**.

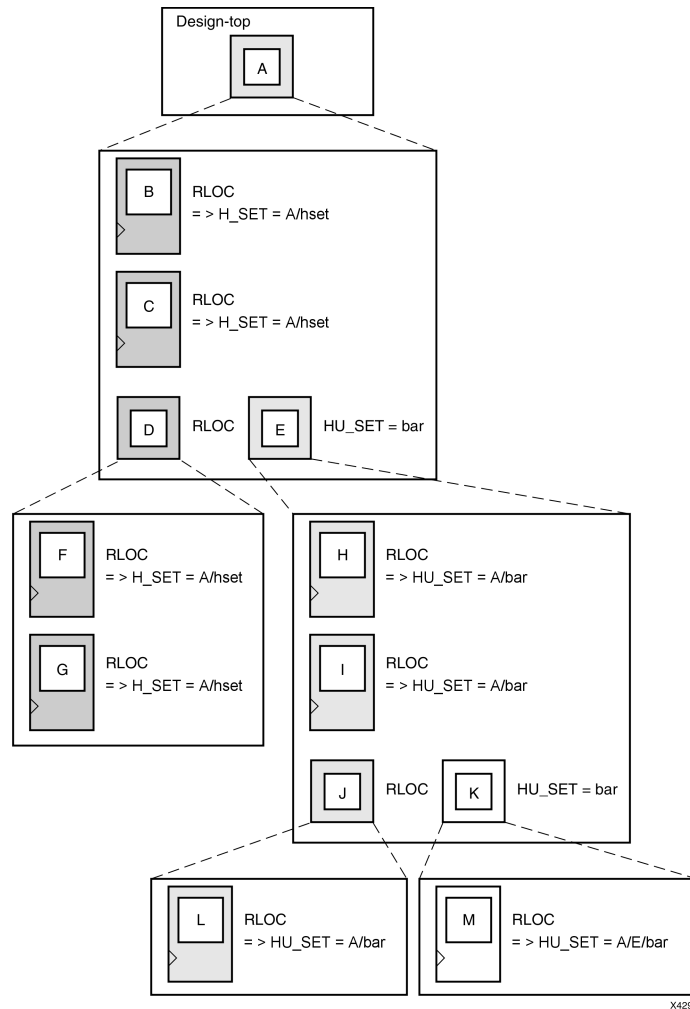

This example demonstrates how **HU_SET** constraints designate elements as set members, break links between elements tagged with RLOC constraints in the hierarchy to separate them from **H_SET** sets, and generate names as identifiers of these sets.

The user-defined **HU_SET** constraint on **E** separates its underlying design elements, namely **H**, **I**, **J**, **K**, **L**, and **M** from the implicit **H_SET=A/h_set** that contains primitive members **B**, **C**, **F**, and **G**. The **HU_SET** set that is defined at **E** includes **H**, **I**, and **L** (through the element **J**).

The mapper hierarchically qualifies the name value “bar” on element **E** to be **A/bar**, since **A** is the lowest common ancestor for all the elements of the **HU_SET** set, and attaches it to the set member primitives **H**, **I**, and **L**. An **HU_SET** constraint on **K** starts another set that includes **M**, which receives the **HU_SET=A/E/bar** constraint after processing by the mapper.

The same name field is used for the two **HU_SET** constraints, but because they are attached to symbols at different levels of the hierarchy, they define two different sets.

Linking Two HU_SET Sets

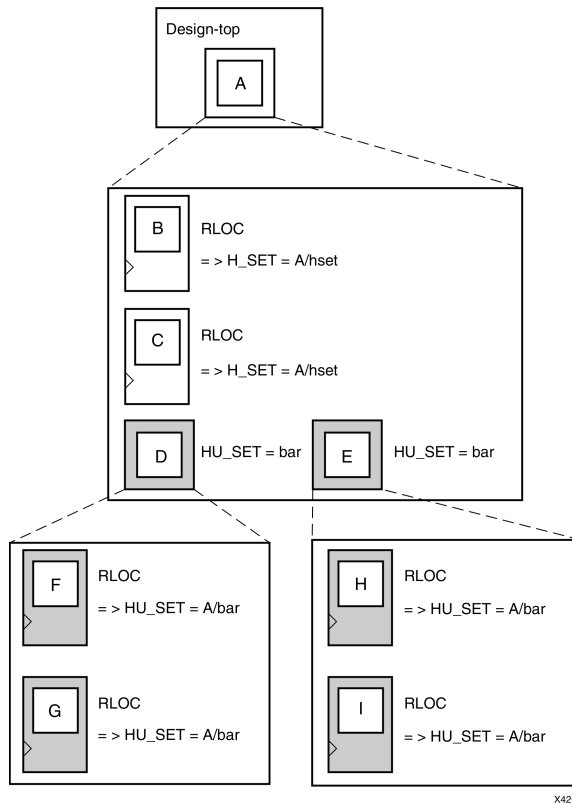

This example shows how **HU_SET** constraints link elements in the same node together by naming them with the same identifier. Because of the same name (**bar**) on two elements, **D** and **E**, the elements tagged with RLOC constraints below **D** and **E** become part of the same **HU_SET**.

Using RLOCs with Xilinx Macros

Xilinx®-supplied flip-flop macros include an **RLOC=R0C0** constraint on the underlying primitive, which allows you to attach an RLOC to the macro symbol. This symbol links the underlying primitive to the set that contains the macro symbol.

Simply attach an appropriate RLOC constraint to the instantiation of the Xilinx flip-flop macro. The mapper adds the RLOC value that you specified to the underlying primitive so that it has the desired value.

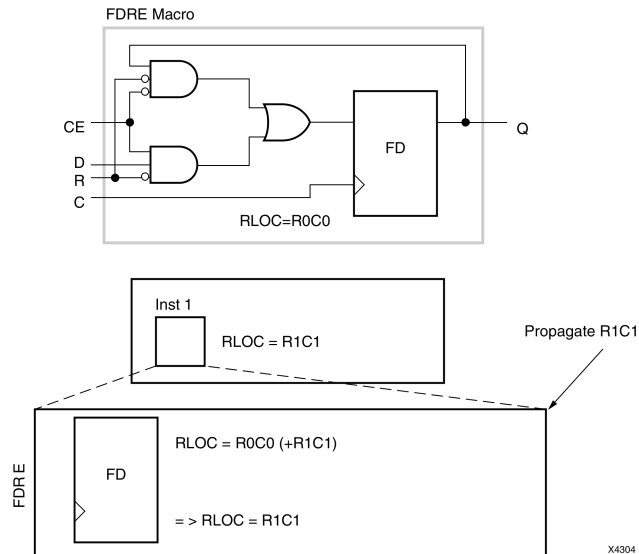

In this example, the **RLOC = R1C1** constraint is attached to the instantiation (**Inst1**) of an example macro. It is added to the **R0C0** value of the RLOC constraint on the flip-flop within the macro to obtain the new RLOC values.

If the **RLOC=X1Y1** constraint is attached to **Inst1** of a macro, the **X0Y0** value of the RLOC constraint on the flip-flop within the macro would be used to obtain the new RLOC values.

If you do not put an RLOC constraint on the flip-flop macro symbol, the underlying primitive symbol is the lone member of a set. The mapper removes RLOC constraints from a primitive that is the only member of a set or from a macro that has no RLOC objects below it.

Syntax Examples

The following examples show how to use this constraint with particular tools or methods. If a tool or method is not listed, you cannot use this constraint with it.

Schematic Syntax

- Attach to an instance
- Attribute Name
RLOC
- Attribute Values
See *Constraint Syntax* above.

VHDL Syntax

Declare the VHDL constraint as follows:

```
attribute rloc: string;
```

Specify the VHDL constraint as follows:

attribute rloc of {*component_name*|*entity_name*|*label_name*}; {**component** | **entity** | **label**}
is “[*element*]**X** *m***Y***n*[*.extension*]”;

For descriptions of valid values, see [Guidelines for Specifying Relative Locations](#).

For more information about basic VHDL syntax, see [VHDL Attributes](#).

The following code sample shows how to use RLOCs with a VHDL generate statement. The code is a simple example showing how to auto-generate the RLOCs for several instantiated FDEs. This methodology can be used with virtually any primitive.

Note The user must create the **itoa** function.

```
LEN:for i in 0 to bits-1 generate
  constant row :natural:=((width-1)/2)-(i/2);
  constant column:natural:=0;
  constant slice:natural:=0;
  constant rloc_str : string := "R" & itoa(row) & "C" & itoa(column) & ".S" & itoa(slice);
  attribute RLOC of U1: label is rloc_str;
begin
  U1: FDE port map (
    Q=> dd(j),
    D=> ff_d,
    C=> clk,
    CE =>lcl_en(en_idx));
end generate LEN;
```

Verilog Syntax

Place the Verilog constraint immediately before the module or instantiation.

Specify the Verilog constraint as follows:

(* **RLOC** = “[*element*]**X***m***Y***n*[*.extension*]” *)

For descriptions of valid value, see [Guidelines for Specifying Relative Locations](#) in this chapter.

For more information about basic Verilog syntax, see [Verilog Attributes](#).

UCF and NCF Syntax

For all FPGA devices, the following statement specifies that an instantiation of **FF1** be placed in a slice that is **+4 X** coordinates and **+4 Y** coordinates relative to the origin slice.

INST “/V2/design/FF1” RLOC=X4Y4;

XCF Syntax

For Virtex®-4 and Virtex-5 devices:

BEGIN MODEL “*entity_name*”

INST “*instance_name*” **rloc**=*[element]***X***m***Y***n* [*.extension*];

END;

PlanAhead Syntax

For more information about using the PlanAhead software to create constraints, see *Floorplanning the Design* in the *PlanAhead User Guide* (UG632). See [PlanAhead](#) in this Guide for information about:

- Defining placement constraints
- Assigning placement constraints
- Defining I/O pin configurations
- Floorplanning and placement constraints

Guidelines for Specifying Relative Locations

The slice-based coordinate system for assigning elements to relative location uses the following general syntax.

RLOC=X m Y n

where

- m and n are the relative **X** axis (left/right) value and the relative **Y** axis (up/down) value, respectively.
- **X** and **Y** numbers can be zero or any positive or negative integer

Because the **X** and **Y** numbers in **RLOC** constraints define only the order and relationship between design elements, and not their absolute die locations, their numbering can include negative numbers. Even though you can use any integer for **RLOC** constraints, Xilinx® recommends small integers for clarity and ease of use.

The *absolute* values of **X** and **Y** is not important in **RLOC** specifications, but rather their *relative* values or differences. For example, if design element **A** has an **RLOC=X3Y4** constraint and design element **B** has an **RLOC=X6Y7** constraint, the absolute values of **X** (3 and 6) are not important in themselves. However, the difference between them is significant. In this case, 3 (6-3) specifies that the location of design element **B** is three slices away from the location of design element **A**.

To capture this information, a normalization process is used and y coordinate-wise, element is 3 (7-4) slices above element **A**. In the example just given, normalization reduces the **RLOC** on design element **A** to **X0Y0**, and the **RLOC** on design element **B** to **X3Y3**.

In Spartan®-3 devices and higher and Virtex®-4 devices and higher, slices are numbered on an **XY** grid beginning in the lower left corner of the chip. **X** ascends in value horizontally to the right. **Y** ascends in value vertically up. **RLOC** constraints follow the Cartesian-based convention.

Different RLOC Specifications for Four Flip-Flop Primitives



X9419

This figure demonstrates the use of **RLOC** constraints. In diagram (a), four flip-flop primitives named **A**, **B**, **C**, and **D** are assigned **RLOC** constraints. These **RLOC** constraints require each flip-flop to be placed in a different slice with the slices stacked in the order shown: **A** below **B**, **C**, and **D**.

To place more than one of these flip-flop primitives per slice, specify the **RLOC** constraints as shown in the diagram. The arrangement in the figure requires that **A** and **B** be placed in a single slice, and that **C** and **D** be placed in another slice immediately to the right of the **AB** slice.

Relative Location (RLOC) Sets

Relative Location (RLOC) constraints give order and structure to related design elements. This section describes **RLOC** sets, which are groups of related design elements to which **RLOC** constraints have been applied. For example, the four flip-flops in [Different RLOC Specifications for Four Flip-Flop Primitives](#) are related by **RLOC** constraints and form a set. Elements in a set are related by **RLOC** constraints to other elements in the same set. Each member of a set must have an **RLOC** constraint, which relates it to other elements in the same set. You can create multiple sets, but a design element can belong to only one set.

Sets can be defined explicitly through the use of a set parameter or implicitly through the structure of the design hierarchy.

Four distinct types of rules are associated with each set.

- *Definition rules* define the requirements for membership in a set.
- *Linkage rules* specify how elements can be linked to other elements to form a single set.
- *Modification rules* dictate how to specify parameters that modify **RLOC** values of all the members of the set.
- *Naming rules* specify the nomenclature of sets.

These rules are discussed in the sections that follow.

The following sections discuss three different set constraints:

- **U_SET** (U SET)
- **H_SET** (H Set)
- **HU_SET** (HU Set)

Elements must be tagged with both the **RLOC** constraint and one of these set constraints to belong to a set.

U_SET (U SET)

U_SET (U SET) allows you to group into a single set design elements with attached **RLOC** constraints that are distributed throughout the design hierarchy. The letter U in the name **U_SET** indicates that the set is user-defined.

U_SET allows you to group elements, even though they are not directly related by the design hierarchy. By attaching a **U_SET** constraint to design elements, you can explicitly define the members of a set.

The design elements tagged with a **U_SET** constraint can exist anywhere in the design hierarchy. They can be primitive or non-primitive symbols. When attached to non-primitive symbols, the **U_SET** constraint propagates to all the primitive symbols with **RLOC** constraints that are below it in the hierarchy.

The syntax of **U_SET** is:

U_SET=*set_name*

where

set_name is the user-specified identifier of the set

All design elements with **RLOC** constraints tagged with the same **U_SET** constraint name belong to the same set. Names therefore must be unique among all the sets in the design.

H_SET (H Set)

In contrast to [U_SET](#), which you explicitly define by tagging design elements, [H_SET \(H Set\)](#) is defined implicitly through the design hierarchy. The combination of the design hierarchy and the presence of [RLOC](#) constraints on elements defines a hierarchical set, or [H_SET](#) set.

You can *not* use [H_SET](#) to tag the design elements to indicate their set membership. The set is defined automatically by the design hierarchy.

All design elements with [RLOC](#) constraints at a single node of the design hierarchy are considered to be in the same [H_SET](#) set unless they are tagged with another type of set constraint such as [Relative Location Origin \(RLOC_ORIGIN\)](#) or [Relative Location Range \(RLOC_RANGE\)](#). If you explicitly tag any element with [RLOC_ORIGIN](#), [RLOC_RANGE](#), [U_SET](#), or [HU_SET](#), it is removed from an [H_SET](#) set.

Most designs contain only [H_SET](#) constraints, since they are the underlying mechanism for relationally placed macros. The [Relative Location Origin \(RLOC_ORIGIN\)](#) or [Relative Location Range \(RLOC_RANGE\)](#) constraints are discussed further in *Set Modifiers*.

NGDBuild does the following:

1. Recognizes the implicit [H_SET](#) set
2. Derives its name or identifier
3. Attaches the [H_SET](#) constraint to the correct members of the set
4. Writes them to the output file

HU_SET (HU Set)

[HU_SET \(HU Set\)](#) is a variation of the implicit [H_SET](#). Like [H_SET](#), [HU_SET](#) is defined by the design hierarchy. However, you can use the [HU_SET](#) constraint to assign a user-defined name to the [HU_SET](#).

The syntax of [HU_SET](#) is:

HU_SET=*set_name*

where

- *set_name* is the identifier of the set
- *set_name* must be unique among all the sets in the design

This user-defined name is the base name of the [HU_SET](#) set. Like the [H_SET](#) set, in which the base name of **h_set** is prefixed by the hierarchical name of the lowest common ancestor of the set elements, the user-defined base name of an [HU_SET](#) set is prefixed by the hierarchical name of the lowest common ancestor of the set elements.

You must define the base names to ensure unique hierarchically qualified names for the sets before the mapper resolves the design and attaches the hierarchical names as prefixes.

[HU_SET](#) defines the start of a new set. All design elements at the same node that have the same user-defined value for the [HU_SET](#) constraint are members of the same [HU_SET](#) set. Along with the [HU_SET](#) constraint, elements can also have an [RLOC](#) constraint.

The presence of an [RLOC](#) constraint in an [H_SET](#) constraint links the element to all elements tagged with [RLOC](#) constraints above and below in the hierarchy. However, in the case of an [HU_SET](#) constraint, the presence of an [RLOC](#) constraint along with the [HU_SET](#) constraint on a design element does not automatically link the element to other elements with [RLOC](#) constraints at the same hierarchy level or above.

Macro A Instantiated Twice

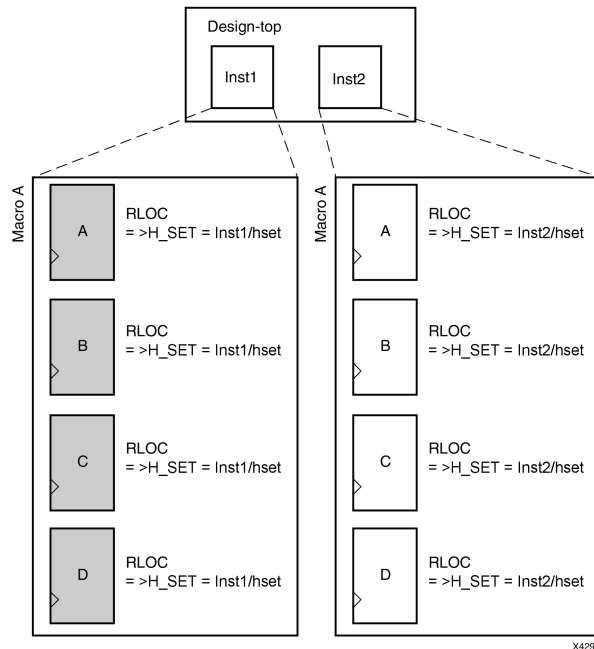

Note In this figure and the other related figures shown in the subsequent sections, the italicized text prefixed by => is added by NGDDBuild during the design flattening process. You add all other text.

This figure demonstrates a typical use of the implicit `H_SET`. The figure shows only the first `RLOC` portion of the constraint.

In a real design, the `RLOC` constraint must be specified completely with:

`RLOC=R mCn`

For Spartan®-3 devices and higher and Virtex®-4 devices and higher the `RLOC` constraint must be specified completely with:

`RLOC=XmYn`

In this example, macro `A` is originally designed with `RLOC` constraints on four flip-flops:

- A
- B
- C
- D

The macro is then instantiated twice in the design:

- Inst1
- Inst2

When the design is flattened, two different `H_SET` sets are recognized because two distinct levels of hierarchy contain elements with `RLOC` constraints. NGDDBuild creates and attaches the appropriate `H_SET` constraint to the set members:

- `H_SET=Inst1/h_set` for the macro instantiated in `Inst1`
- `H_SET=Inst2/h_set` for the macro instantiated in `Inst2`

The design implementation programs place each of the two sets individually as a unit with relative ordering within each set specified by the `RLOC` constraints. However, the two sets are regarded to be completely independent of each other.

The name of the **H_SET** set is derived from the symbol or node in the hierarchy that includes all the **RLOC** elements. **Inst1** is the node (instantiating macro) that includes the four flip-flop elements with **RLOC** constraints shown on the left of the figure. Therefore, the name of this **H_SET** set is the hierarchically qualified name of **Inst1** followed by **h_set**.

The **Inst1** symbol is considered the start of the **H_SET**, which gives a convenient handle to the entire **H_SET** and attaches constraints that modify the entire **H_SET**. Constraints that modify sets are discussed in the **Save Net Flag (SAVE NET FLAG)** constraint.

This figure demonstrates the simplest use of a set that is defined and confined to a single level of hierarchy. Through linkage and modification, you can also create an **H_SET** set that is linked through two or more levels of hierarchy.

Linkage allows you to link elements through the hierarchy into a single set. On the other hand, modification allows you to modify **RLOC** values of the members of a set through the hierarchy.

RLOC Set Summary

The following table summarizes the **RLOC** set types and the constraints that identify members of these sets.

Summary of Set Types

Type	Definition	Naming	Linkage	Modification
U_SET= name	All elements with the same user-tagged U_SET constraint value are members of the same U_SET set.	The name of the set is the same as the user-defined name without any hierarchical qualification.	U_SET links elements to all other elements with the same value for the U_SET constraint.	U_SET is modified by applying RLOC_ORIGIN or RLOC_RANGE constraints on, at most, one of the U_SET constraint-tagged elements.
HU_SET= name	All elements with the same hierarchically qualified name are members of the same set.	The lowest common ancestor of the members is prefixed to the user-defined name to obtain the name of the set.	HU_SET links to other elements at the same node with the same HU_SET constraint value. It links to elements with RLOC constraints below.	The start of the set is made up of the elements on the same node that are tagged with the same HU_SET constraint value. A RLOC_ORIGIN or a RLOC_RANGE constraint can be applied to, at most, one of these start elements of an HU_SET set.

RLOC_ORIGIN (Relative Location Origin)

The RLOC_ORIGIN (Relative Location Origin) constraint:

- Is a placement constraint.
- Fixes the members of a set at exact die locations.
- Must specify a single location, not a range or a list of several locations.
For more information, see *Set Modifiers* in the [Relative Location \(RLOC\)](#) constraint.
- Is required for a set that includes BUFT symbols.
- Cannot be attached to a BUFT instance.

Architecture Support

Applies to FPGA devices. Does not apply to CPLD devices.

Applicable Elements

Instances or macros that are members of sets

Propagation Rules

RLOC_ORIGIN is a macro constraint and any attachment to a net is illegal.

When RLOC_ORIGIN is used in conjunction with an implicit [H_SET](#), it must be placed on the element that is the start of the [H_SET](#) set, that is, on the lowest common ancestor of all the members of the set.

If you apply RLOC_ORIGIN to an [HU_SET](#) constraint, place it on the element at the start of the [HU_SET](#) set, that is, on an element with the [HU_SET](#) constraint.

However, since there could be several elements linked together with the [HU_SET](#) constraint at the same node, the RLOC_ORIGIN constraint can be applied to only one of these elements to prevent more than one RLOC_ORIGIN constraint from being applied to the [HU_SET](#) set.

Similarly, when used with a [U_SET](#) constraint, the RLOC_ORIGIN constraint can be placed on only one element with the [U_SET](#) constraint. If you attach the RLOC_ORIGIN constraint to an element that has only an RLOC constraint, the membership of that element in any set is removed, and the element is considered the start of a new [H_SET](#) set with the specified RLOC_ORIGIN constraint attached to the newly created set.

Constraint Syntax

To specify a single origin for an RLOC set, use the following syntax, which is equivalent to placing an RLOC_ORIGIN constraint on the schematic.

```
set_name RLOC_ORIGIN=Xm Yn
```

where

- *set_name* can be the name of any type of RLOC set:
 - [U_SET](#)
 - [HU_SET](#)
 - system-generated [H_SET](#)
- The origin itself is expressed as an **X** and **Y** value representing the location of the elements at **RLOC=X0Y0**

Syntax Examples

The following examples show how to use this constraint with particular tools or methods. If a tool or method is not listed, you cannot use this constraint with it.

Schematic Syntax

- Attach to an instance that is a member of a set
- Attribute Name
RLOC_ORIGIN
- Attribute Values

For a list of the constraint values, see the *UCF and NCF Syntax* section below.

VHDL Syntax

Declare the VHDL constraint as follows:

```
attribute rloc_origin: string;
```

Specify the VHDL constraint as follows:

```
attribute rloc_origin of {component_name | entity_name | label_name} : {component | entity | label} is " value";
```

For Spartan®-3, Spartan-3A, Spartan-3E, Virtex®-4 and Virtex-5 devices, *value* is **X mYn**.

For a list of the constraint values, see the *UCF and NCF Syntax* section below.

For more information about basic VHDL syntax, see [VHDL Attributes](#).

Verilog Syntax

Place the Verilog constraint immediately before the module or instantiation.

Specify the Verilog constraint as follows:

```
(* RLOC_ORIGIN = " value" *)
```

For Spartan-3, Spartan-3A, Spartan-3E, Virtex-4 and Virtex-5 devices, *value* is **X mYn**.

For a list of the constraint values, see the *UCF and NCF Syntax* section below.

For more information about basic Verilog syntax, see [Verilog Attributes](#).

UCF and NCF Syntax for Architectures Using Slice-Based XY Coordinates

This section applies to Spartan-3, Spartan-3A, Spartan-3E, Virtex-4, and Virtex-5 devices.

```
RLOC_ORIGIN=X mYn
```

where

m and *n* are positive or negative integers (including zero) representing relative X and Y coordinates, respectively

The following statement specifies that an instantiation of **FF1**, which is a member of a set, be placed in the slice at **X4Y4** relative to **FF1**.

```
INST "/archive/designs/FF1" RLOC_ORIGIN=X4Y4;
```

For example, if **RLOC=X0Y2** for **FF1**, then the instantiation of **FF1** is placed in the slice that is:

- 0 rows to the right of **X4**
- 2 rows up from **Y4** (**X4Y6**)

PlanAhead Syntax

For more information about using the PlanAhead software to create constraints, see *Floorplanning the Design* in the *PlanAhead User Guide (UG632)*. See [PlanAhead](#) in this Guide for information about:

- Defining placement constraints
- Assigning placement constraints
- Defining I/O pin configurations
- Floorplanning and placement constraints

RLOC_RANGE (Relative Location Range)

The RLOC_RANGE (Relative Location Range) constraint:

- Is a placement constraint.
- Is similar to [RLOC_ORIGIN](#) except that it limits the members of a set to a certain range on the die. The range or list of locations is meant to apply to all applicable elements with RLOCs, not just to the origin of the set

Architecture Support

Applies to FPGA devices. Does not apply to CPLD devices.

Applicable Elements

Instances or macros that are members of sets

Propagation Rules

RLOC_RANGE is a macro constraint and any attachment to a net is illegal.

The bounding rectangle applies to all elements in a relationally placed macro, not just to the origin of the set.

The values of the RLOC_RANGE constraint are not simply added to the RLOC values of the elements. In fact, the RLOC_RANGE constraint does not change the values of the RLOC constraints on underlying elements. It is an additional constraint that is attached automatically by the mapper to every member of a set.

The RLOC_RANGE constraint is attached to design elements in exactly the same way as the [RLOC_ORIGIN](#) constraint. The values of the RLOC_RANGE constraint, like [RLOC_ORIGIN](#) values, must be non-zero positive numbers since they directly correspond to die locations.

If a particular RLOC set is constrained by an [RLOC_ORIGIN](#) or an RLOC_RANGE constraint in the design netlist and is also constrained in the User Constraints File (UCF) file, the UCF constraint overrides the netlist constraint.

Constraint Syntax

RLOC_RANGE=Xm1 Yn1:X m2Yn2

where

the relative X values ($m1$ and $m2$) and Y values ($n1$ and $n2$) can be:

- non-zero positive numbers
- the wildcard (*) character

This syntax allows for three kinds of range specifications:

- **Xm1Yn1:Xm2 Yn2**

A rectangular region bounded by the corners **Xm1Yn1** and **Xm2 Yn2**

- **X*Yn1:X*Ym2**

The region on the Y-axis between $n1$ and $n2$ (any X value)

- **Xm1Y*:Xm2**

A region on the X-axis between $m1$ and $m2$ (any Y value)

For the second and third kinds of specifications with wildcards, applying the wildcard character (*) differently on either side of the separator colon creates an error. For example, specifying **X*Y1:X2Y*** is an error since the wildcard asterisk is applied to the **X** value on one side and to the **Y** value on the other side of the separator colon.

To specify a range, use the following syntax, which is equivalent to placing an **RLOC_RANGE** constraint on the schematic.

```
set_name RLOC_RANGE=X m1Yn1 :Xm2Y n2
```

The range identifies a rectangular area. You can substitute a wildcard (*) character for either the **X** value or the **Y** value of both corners of the range.

Syntax Examples

The following examples show how to use this constraint with particular tools or methods. If a tool or method is not listed, you cannot use this constraint with it.

Schematic Syntax

- Attach to an instance that is a member of a set
- Attribute Name
RLOC_RANGE
- Attribute Values
 - positive integers (including zero)
 - the wildcard (*) character

VHDL Syntax

Declare the VHDL constraint as follows:

```
attribute rloc_range: string;
```

Specify the VHDL constraint as follows:

```
attribute rloc_range of {component_name|entity_name|label_name}:  
{component|entity|label} is "value";
```

For Spartan®-3, Spartan-3A, Spartan-3E, Virtex®-4 and Virtex-5 devices *value* is:

```
Xm1Yn1:Xm2Yn2
```

For a list of the constraint values, see the *UCF and NCF Syntax* section below.

For more information about basic VHDL syntax, see [VHDL Attributes](#).

Verilog Syntax

Place the Verilog constraint immediately before the module or instantiation.

Specify the Verilog constraint as follows:

```
(* RLOC_RANGE = "value" *)
```

For Spartan-3, Spartan-3A, Spartan-3E, Virtex-4 and Virtex-5 devices, *value* is:

```
Xm1Yn1:Xm2Yn2
```

For a list of the constraint values, see the *UCF and NCF Syntax* section below.

For more information about basic Verilog syntax, see [Verilog Attributes](#).

UCF and NCF Syntax

This section is applicable Spartan-3 devices and up, and Virtex-4 devices and up.

```
RLOC_RANGE=Xm1Yn1:Xm2Yn2
```

where

the relative X values ($m1$ and $m2$) and Y values ($n1$ and $n2$) can be:

- positive integers (including zero)
- the wildcard (*) character

The following statement specifies that an instantiation of the macro **MACRO4** be placed relative to other members of the set within a region that is bounded by:

- **X4Y4** in the lower left corner
- **X10Y10** in the upper right corner

```
INST "/archive/designs/MACRO4" RLOC_RANGE=X4Y4:X10Y10;
```

XCF Syntax

```
MODEL "entity_name" rloc_range=value;
```

```
BEGIN MODEL "entity_name"
```

```
  INST "instance_name" rloc_range=value;
```

```
END;
```

SAVE NET FLAG (Save Net Flag)

The SAVE NET FLAG (Save Net Flag) constraint:

- Is a basic mapping constraint.
- When attached to nets or signals, affects the mapping, placement, and routing of the design by preventing the removal of unconnected signals.
- Prevents the removal of loadless or driverless signals.
 - For *loadless* signals, SAVE NET FLAG acts as a dummy OBUF load connected to the signal.
 - For *driverless* signals, SAVE NET FLAG acts as a dummy IBUF driver connected to the signal.
- Can be abbreviated as S NET FLAG.

If you do not have SAVE NET FLAG on a net, any signal that cannot be observed or controlled via a path to an I/O primitive is removed.

SAVE NET FLAG may prevent the trimming of logic connected to the signal.

Architecture Support

Applies to FPGA devices. Does not apply to CPLD devices.

Applicable Elements

- Nets
- Signals

Propagation Rules

This constraint:

- Is a net or signal constraint. Any attachment to a design element is illegal
- Prevents the removal of unconnected signals. If you do not have the S constraint on a net, any signal not connected to logic or an I/O primitive is removed.

SAVE NET FLAG Syntax

The following examples show how to use this constraint with particular tools or methods. If a tool or method is not listed, you cannot use this constraint with it.

Schematic Syntax

- Attach to a net or signal
- Attribute Name
- Attribute Values
 - TRUE
 - FALSE

VHDL Syntax

Declare the VHDL constraint as follows:

```
attribute S: string;
```

Specify the VHDL constraint as follows:

```
attribute S of signal_name : signal is "{YES|NO|TRUE|FALSE}";
```

For more information about basic VHDL syntax, see [VHDL Attributes](#).

Verilog Syntax

Place the Verilog constraint immediately before the module or instantiation.

Specify the Verilog constraint as follows:

```
(* S = {YES|NO|TRUE|FALSE} *)
```

For more information about basic Verilog syntax, see [Verilog Attributes](#).

UCF and NCF Syntax

The following statement specifies that the net or signal named `$$SIG_9` should not be removed.

```
NET $$SIG_9 S;
```

XCF Syntax

```
BEGIN MODEL entity_name
```

```
NET "signal_name" s=true;
```

```
END;
```

SCHMITT_TRIGGER (Schmitt Trigger)

The SCHMITT_TRIGGER (Schmitt Trigger) constraint:

- Causes the attached input pad to be configured with Schmitt Trigger (hysteresis).
- Applies to any input pad in the design.

Architecture Support

Applies to CoolRunner™-II devices only.

Applicable Elements

All input pads and pad nets

Propagation Rules

This constraint is a net or signal constraint. Any attachment to a macro, entity, or module is illegal.

Syntax Examples

The following examples show how to use this constraint with particular tools or methods. If a tool or method is not listed, you cannot use this constraint with it.

Schematic Syntax

- Attach to a net
- Attribute Name
SCHMITT_TRIGGER
- Attribute Values
TRUE
FALSE

VHDL Syntax

Declare the VHDL constraint as follows:

```
attribute SCHMITT_TRIGGER: string;
```

Specify the VHDL constraint as follows:

```
attribute SCHMITT_TRIGGER of signal_name : signal is "{TRUE|FALSE}";
```

For more information about basic VHDL syntax, see [VHDL Attributes](#).

Verilog Syntax

Place the Verilog constraint immediately before the module or instantiation.

Specify the Verilog constraint as follows:

```
(* SCHMITT_TRIGGER = "{TRUE|FALSE}" *)
```

For more information about basic Verilog syntax, see [Verilog Attributes](#).

UCF and NCF Syntax

```
NET "mysignal" SCHMITT_TRIGGER;
```

XCF Syntax

```
BEGIN MODEL "entity_name "  
NET "signal_name" SCHMITT_TRIGGER=true;  
END;
```

SIM Collision Check (SIM_COLLISION_CHECK)

The SIM Collision Check (SIM_COLLISION_CHECK) constraint is used to specify simulation model behavior when a read/write collision occurs on a memory location of Block RAM.

Architecture Support

This constraint applies to Virtex®-4 devices and higher only. It does not apply to Spartan® devices or to CPLD devices.

Applicable Elements

Block RAM primitive elements

Propagation Rules

It is illegal to attach this constraint to a net or signal.

Syntax Examples

The following examples show how to use this constraint with particular tools or methods. If a tool or method is not listed, you cannot use this constraint with it.

Values

- **ALL**
Generates both a WARNING message and X's on the output during simulation.
- **NONE**
Ignores collisions leading to unpredictable results during simulation.
- **WARNING_ONLY**
Generates a WARNING message during simulation if there is a read/write collision on a memory location in the Virtex-4 block RAM memory,
- **GENERATE_X_ONLY**
Generates X's on the outputs during simulation.

Schematic Syntax

- Attached to a block RAM primitive
- Attribute Name
SIM_COLLISION_CHECK
- Attribute Values
See *Values* section above.

VHDL Syntax

Declare the VHDL constraint as follows:

```
attribute sim_collision_check: string;
```

Specify the VHDL constraint as follows:

```
attribute sim_collision_check of {component_name\label_name}: {component|label} is  
"sim_collision_check_value";
```

For more information about basic VHDL syntax, see [VHDL Attributes](#).

Verilog Syntax

Place the Verilog constraint immediately before the module or instantiation.

Specify the Verilog constraint as follows:

```
// synthesis attribute sim_collision_check [of] {module_name|instance_name} [is]
"sim_collision_check_value";
```

For more information about basic Verilog syntax, see [Verilog Attributes](#).

UCF and NCF Syntax

The following statement sets the SIM_COLLISION_CHECK constraint for an instantiation of an I/O primitive element **y2**.

```
INST "$1187/y2
SIM_COLLISION_CHECK={WARNING_ONLY|GENERATE_X_ONLY|ALL|NONE};
```

SLEW (Slew)

The SLEW (Slew) constraint:

- Defines the slew rate (rate of transition) behavior of each individual output to the device.
- May be placed on any output or bi-directional port to specify the port slew rate to be:
 - **SLOW** (default)
 - **FAST**
 - **QUIETIO** (Spartan®-3A devices)

Use the slowest SLEW attribute available to the device while still allowing applicable I/O timing to be met in order to minimize any possible signal integrity issues.

Architecture Support

Applies to all FPGA devices and all CPLD devices.

Applicable Elements

Output primitives, output pads, bidirectional pads.

You can also attach SLEW to the net connected to the pad component in a User Constraints File (UCF). NGCBuild transfers SLEW from the net to the pad instance in the NGD file so that it can be processed by the mapper. Use the following syntax:

```
NET "net_name" slew={FAST|SLOW};
```

Propagation Rules

SLEW should only be placed on a top-level output or bi-directional port.

Syntax

The following examples show how to use this constraint with particular tools or methods. If a tool or method is not listed, you cannot use this constraint with it.

Values

- **FAST**
- **SLOW**
- **QUIETIO**
Spartan-3A devices only

Schematic Syntax

Specify a new attribute to an output port, or bi-directional port:

- Attribute Name
SLEW
- Attribute Values
See *Values* section above.

VHDL Syntax

Before using SLEW, declare it with the following syntax placed after the architecture declaration, but before the begin statement in the top-level VHDL file:

```
attribute SLEW: string;
```

Specify the VHDL constraint as follows:

```
attribute SLEW of {top_level_port_name}: signal is "value";
```

VHDL Syntax Example

```
entity top is
port (FAST_OUT: out std_logic);
end top;

architecture MY_DESIGN of top is
attribute SLEW: string;
attribute SLEW of FAST_OUT: signal is "FAST";
begin
```

For more information on basic VHDL syntax, see [VHDL Attributes](#).

Verilog Syntax

Place the following attribute specification before the port declaration in the top-level Verilog code:

```
(* SLEW="value" *)
```

Verilog Syntax Example

```
module top (
(* SLEW="FAST" *) output FAST_OUT
);
```

For more information about basic Verilog syntax, see [Verilog Attributes](#).

User Constraints File (UCF) and Netlist Constraints File (NCF) Syntax

Placed on output or bi-directional port:

```
NET "top_level_port_name" SLEW="value";
```

UCF and NCF Syntax Example

```
NET "FAST_OUT" SLEW="FAST";
```

PlanAhead Syntax

For more information about using the PlanAhead software to create constraints, see *Floorplanning the Design* in the *PlanAhead User Guide (UG632)*. See [PlanAhead](#) in this Guide for information about:

- Defining placement constraints
- Assigning placement constraints
- Defining I/O pin configurations
- Floorplanning and placement constraints

PACE Syntax

To set SLEW in PACE, select the pin value in the Design Objects window.

PACE is supported for CPLD devices only.

SLOW (Slow)

The SLOW (Slow) constraint:

- Is a basic fitter constraint
- Enables the slew rate limited control

Architecture Support

Applies to all FPGA devices and all CPLD devices.

Applicable Elements

- Output primitives
- Output pads
- Bidirectional pads

You can also attach SLOW to the net connected to the pad component in a User Constraints File (UCF). NGCBuild transfers SLOW from the net to the pad instance in the Native Generic Database (NGD) file so that it can be processed by the mapper.

Use the following UCF syntax:

```
NET "net_name" SLOW;
```

Propagation Rules

SLOW is illegal when attached to a net except when the net is connected to a pad. In this case, SLOW is treated as attached to the pad instance.

When attached to a design element, SLOW propagates to all applicable elements in the hierarchy within the design element.

Syntax

The following examples show how to use this constraint with particular tools or methods. If a tool or method is not listed, you cannot use this constraint with it.

Schematic Syntax

- Attach to a valid instance
- Attribute Name
SLOW
- Attribute Values
 - TRUE
 - FALSE

VHDL Syntax

Declare the VHDL constraint as follows:

```
attribute SLOW : string;
```

Specify the VHDL constraint as follows:

```
attribute SLOW of {signal_name|entity_name} : {signal|entity} is "{TRUE|FALSE}";
```

For more information about basic VHDL syntax, see [VHDL Attributes](#).

Verilog Syntax

Place the Verilog constraint immediately before the module or instantiation.

Specify the Verilog constraint as follows:

```
(* SLOW = "{TRUE|FALSE}" *)
```

For more information about basic Verilog syntax, see [Verilog Attributes](#).

UCF and NCF Syntax

The following statement establishes a slow slew rate for an instantiation of the element `y2`.

```
INST "$1I87/y2" SLOW;
```

The following statement establishes a slow slew rate for the pad to which `net1` is connected.

```
NET "net1" SLOW;
```

PlanAhead Syntax

For more information about using the PlanAhead software to create constraints, see *Floorplanning the Design* in the *PlanAhead User Guide (UG632)*. See [PlanAhead](#) in this Guide for information about:

- Defining placement constraints
- Assigning placement constraints
- Defining I/O pin configurations
- Floorplanning and placement constraints

STEPPING (Stepping)

The STEPPING (Stepping) constraint is assigned a value that matches the step level marking on the silicon. The step level identifies specific device capabilities. Xilinx® recommends that the step level be set for the design using STEPPING. Otherwise, the software uses a default target device.

For more information on STEPPING, see Xilinx [Answer Record 20947](#), *Stepping FAQs*.

Architecture Support

- CoolRunner™-II
- Spartan®-3A, Spartan-3E, Virtex®-4, Virtex-5

Applicable Elements

The STEPPING attribute is a global CONFIG constraint and is not attached to any instance or signal name.

Propagation Rules

Applies to the entire design.

Syntax Examples

The following examples show how to use this constraint with particular tools or methods. If a tool or method is not listed, you cannot use this constraint with it.

UCF Syntax

```
CONFIG STEPPING="n";
```

where

n is the target stepping level (ES, SCD1, 1, 2, 3, ...)

UCF Syntax Example

```
CONFIG STEPPING= " 1 " ;
```

SUSPEND (Suspend)

The SUSPEND (Suspend) constraint:

- Defines the behavior of each individual output when the FPGA device is placed in the SUSPEND power-reduction mode.
- May be placed on any output or bi-directional port to specify the port to be:
 - tristated (*3STATE*) OR
 - pulled high (*3STATE_PULLUP*) or low (*3STATE_PULLDOWN*) OR
 - driven to the last value (*3STATE_KEEPER* or *DRIVE_LAST_VALUE*)
- Has a default value of *3STATE*

Architecture Support

Applies to Spartan®-3A and Spartan-6 devices only.

Applicable Elements

Place this constraint only on a top-level output or bi-directional port targeting a Spartan-3A device or a Spartan-6 device.

Propagation Rules

Place this constraint only on a top-level output or bi-directional port.

Syntax Examples

The following examples show how to use this constraint with particular tools or methods. If a tool or method is not listed, you cannot use this constraint with it.

Values

- *DRIVE_LAST_VALUE*
- *3STATE*
- *3STATE_PULLUP*
- *3STATE_PULLDOWN*
- *3STATE_KEEPER*

Schematic Syntax

Specify a new attribute to an output port or bidirectional port:

- Attribute Name
SUSPEND
- Attribute Values
See *Values* section above.

VHDL Syntax

Before using this constraint, declare it with the following syntax placed after the architecture declaration but before the begin statement in the top-level VHDL file:

attribute SUSPEND: string;

After the constraint has been declared, specify the VHDL constraint as follows:

attribute SUSPEND of {*top_level_port_name*} : signal is "value";

Example:

```
entity top is
port (STATUS: out std_logic);
end top;architecture MY_DESIGN of top is
attribute SUSPEND: string;
attribute SUSPEND of STATUS: signal is "DRIVE_LAST_VALUE";
begin
```

For more information about basic VHDL syntax, see [VHDL Attributes](#).

Verilog Syntax

Place the following attribute specification before the port declaration in the top-level Verilog code:

(* SUSPEND="value" *)

Example:

```
module top ( (* SUSPEND="DRIVE_LAST_VALUE" *) output STATUS );
```

For more information about basic Verilog syntax, see [Verilog Attributes](#).

UCF and NCF Syntax

Placed on an output or bi-directional port:

NET "*top_level_port_name*" SUSPEND="value";

Example:

```
NET "STATUS" SUSPEND="DRIVE_LAST_VALUE" ;
```

PACE Syntax

To set this constraint from the Pinout and Area Constraints Editor (PACE), select the appropriate pin value from the Design Objects window.

SYSTEM_JITTER (System Jitter)

The SYSTEM_JITTER (System Jitter) constraint:

- Specifies the system jitter of the design.
- Depends on design conditions such as:
 - the number of flip-flops changing at one time
 - the number of I/Os changing
- Applies globally to all clocks in the design.
- Is combined with the **INPUT_JITTER** keyword on the **PERIOD** constraint, as well as any jitter or phase error in the clock network, to generate the Clock Uncertainty value that is shown in the timing report.

Architecture Support

Applies to FPGA devices. Does not apply to CPLD devices.

Applicable Elements

Applies to the entire design.

Propagation Rules

Not applicable

Syntax Examples

The following examples show how to use this constraint with particular tools or methods. If a tool or method is not listed, you cannot use this constraint with it.

Values

value is a numerical value. The default is **ps**.

Schematic Syntax

- Attach to a valid instance
- Attribute Name
SYSTEM_JITTER
- Attribute Values
See *Values* section above.

VHDL Syntax

Declare the VHDL constraint as follows:

```
attribute SYSTEM_JITTER: string;
```

Specify the VHDL constraint as follows:

```
attribute SYSTEM_JITTER of {component_name | signal_name | entity_name |  
label_name}: {component | signal | entity | label} is "value ps";
```

For more information about basic VHDL syntax, see [VHDL Attributes](#).

Verilog Syntax

Place the Verilog constraint immediately before the module or instantiation.

Specify the Verilog constraint as follows:

```
(* SYSTEM_JITTER = "value ps" *)
```

For more information about basic Verilog syntax, see [Verilog Attributes](#).

UCF and NCF Syntax

```
SYSTEM_JITTER= value ps;
```

XCF Syntax

```
MODEL "entity_name" SYSTEM_JITTER = value ps;
```

TEMPERATURE (Temperature)

The TEMPERATURE (Temperature) constraint:

- Is a timing constraint.
- Allows the specification of the operating junction temperature.
- Provides a means of prorating device delay characteristics based on the specified temperature.

Prorating is a scaling operation on existing speed file delays and is applied globally to all delays. Newer devices may not support TEMPERATURE prorating until the timing information (speed files) are marked as production status.

Each architecture has its own specific range of valid operating temperatures. If the entered temperature does not fall within the supported range, TEMPERATURE is ignored and an architecture-specific worst-case value is used instead. Also note that the error message for this condition does not appear until static timing.

Architecture Support

- Spartan®-3A
- Spartan-3E
- Virtex®-4
- Virtex-5

Applicable Elements

Applies globally to the entire design.

Propagation Rules

This constraint is a design element constraint. Any attachment to a net is illegal.

Syntax

The following examples show how to use this constraint with particular tools or methods. If a tool or method is not listed, you cannot use this constraint with it.

UCF and NCF Syntax

`TEMPERATURE=value [C | F | K];`

where

value

- is a real number specifying the temperature
- *C*, *K*, and *F* are the temperature units
 - *F* is degrees Fahrenheit
 - *K* is degrees Kelvin
 - *C* is degrees Celsius (default)

The following statement specifies that the analysis for everything relating to speed file delays assumes a junction temperature of 25 degrees Celsius.

`TEMPERATURE=25 C;`

Constraints Editor Syntax

For information on setting constraints in Constraints Editor, including syntax, see the Constraints Editor Help.

TIG (Timing Ignore)

The TIG (Timing Ignore) constraint:

- Is a timing constraint and a synthesis constraint.
- Causes paths that fan forward from the point of application (of TIG) to be treated as if they do not exist (for the purposes of timing analysis) during implementation.
- Can be applied relative to a specific timing specification.
- Can have any of the following values:
 - Empty (global TIG that blocks all paths)
 - A single TSid to block
 - A comma separated list of TSids to block, for example
- Is fully supported by XST.

Example

```
NET "RESET" TIG=TS_fast, TS_even_faster;
```

Architecture Support

Applies to FPGA devices. Does not apply to CPLD devices.

Applicable Elements

- Nets
- Pins
- Instances

Propagation Rules

If TIG is attached to a net, primitive pin, or macro pin, all paths that fan forward from the point of application of the constraint are treated as if they do not exist for the purposes of timing analysis during implementation. In the following figure:

- NET C is ignored
- The lower path of NET B that runs through the two OR gates is not ignored

TIG Example

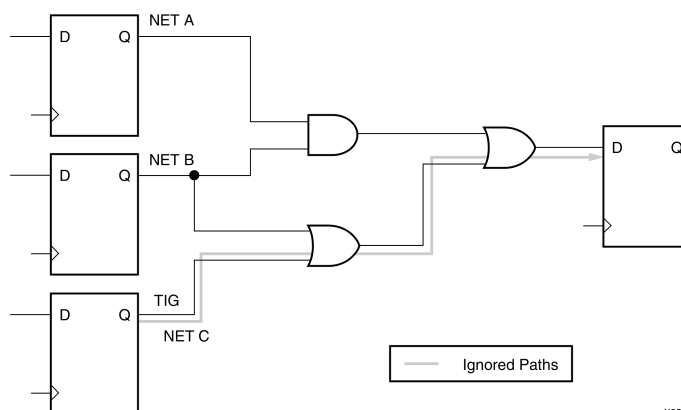

X8529

The following constraint would be attached to a net to inform the timing analysis tools that it should ignore paths through the net for specification TS43.

Schematic Syntax	TIG = TS43
UCF Syntax	NET " <i>net_name</i> " TIG = TS43;

You cannot perform path analysis in the presence of combinatorial loops. Therefore, the timing software ignores certain connections to break combinatorial loops. You can use the TIG constraint to direct the timing tools to ignore specified nets or load pins, consequently controlling how loops are broken.

Syntax

The following examples show how to use this constraint with particular tools or methods. If a tool or method is not listed, you cannot use this constraint with it.

Note TIG does not affect the timing reported at the bottom of the XST report. TIG applies only to the timing reported by Timing Analyzer.

Schematic Syntax

- Attach to a net or pin
- Attribute Name
TIG
- Attribute Values
value

UCF and NCF Syntax

NET " *net_name*" TIG;

PIN "*ff_inst.RST*" TIG=TS_1;

INST "*instance_name*" TIG=TS_2;

TIG=TS *identifier1* . . . TS *identifern*

identifier refers to a timing specification that should be ignored

When attached to an instance, TIG is pushed to the output pins of that instance. When attached to a net, TIG pushes to the drive pin of the net. When attached to a pin, TIG applies to the pin.

The following statement specifies that the timing specifications **TS_fast** and **TS_even_faster** is ignored on all paths fanning forward from the net RESET.

NET "RESET" TIG=TS_fast, TS_even_faster;

XST Constraint File (XCF) Syntax

The XST Constraint File (XCF) syntax is the same as the User Constraints File (UCF) syntax.

XST fully supports the TIG constraint. TIG can be applied to the nets, situated in the CORE files:

- Electronic Data Interchange Format (EDIF)
- Native Generic Database (NGD)

Constraints Editor Syntax

For information on Constraints Editor and Constraints Editor syntax in ISE® Design Suite, see the ISE Design Suite Help.

PlanAhead Syntax

For more information about using the PlanAhead software to create constraints, see *Floorplanning the Design* in the *PlanAhead User Guide (UG632)*. See [PlanAhead](#) in this Guide for information about:

- Defining placement constraints
- Assigning placement constraints
- Defining I/O pin configurations
- Floorplanning and placement constraints

Physical Constraints File (PCF) Syntax

The basic Physical Constraints File (PCF) syntax is:

item **TIG**;

item **TIG** =;

item **TIG** = **TSidentifier** ;

where

item is one of the following:

- **PIN** *name*
- **PATH** *name*
- *path specification*
- **NET** *name*
- **TIMEGRP** *name*
- **BEL** *name*
- **COMP** *name*
- **MACRO** *name*

TIMEGRP (Timing Group)

The TIMEGRP (Timing Group) constraint:

- Uses the [Timing Name \(TNM\)](#) identifier to group design elements together for timing analysis.
- Allows you to:
 - Define groups in terms of other groups
 - Create a group that is a combination of existing groups
 - Place TIMEGRP constraints in a User Constraints File (UCF) or a Netlist Constraints File (NCF)

Architecture Support

Applies to all FPGA devices and all CPLD devices.

Applicable Elements

- Design elements
- Nets

Propagation Rules

Applies to all elements or nets within the group.

Syntax

The following examples show how to use this constraint with particular tools or methods. If a tool or method is not listed, you cannot use this constraint with it.

Syntax Examples

Combining Multiple Groups into One

You can define a group by combining other groups.

Multiple Groups UCF Syntax Example One

The following syntax example illustrates the simple combining of two groups.

```
TIMEGRP "big_group"="small_group" "medium_group";
```

In this syntax example, *small_group* and *medium_group* are existing groups defined using a TNM or TIMEGRP attribute.

Multiple Groups UCF Syntax Example Two

A circular definition, as shown below, causes an error when you run your design through NGCBuild:

```
TIMEGRP "many_ffs"="ffs1" "ffs2";
```

```
TIMEGRP "ffs1"="many_ffs" "ffs3";
```

Creating Groups by Exclusion

You can define a group that includes all elements of one group except the elements that belong to another group, as illustrated by the following syntax examples.

Groups by Exclusion UCF Syntax Example One

```
TIMEGRP "group1"="group2" EXCEPT "group3";
```

where

- *group1* represents the group being defined. It contains all of the elements in *group2* except those that are also in *group3*.
- *group2* and *group3* can be a:
 - valid TNM
 - predefined group
 - TIMEGRP attribute

Groups by Exclusion UCF Syntax Example Two

As illustrated by the following example, you can specify multiple groups to include or exclude when creating the new group.

```
TIMEGRP "group1"=" "group2" "group3" EXCEPT "group4" "group5";
```

The example defines a *group1* that includes the members of *group2* and *group3*, except for those members that are part of *group4* or *group5*. All of the groups before the keyword EXCEPT are included, and all of the groups after the keyword are excluded.

Defining Flip-Flop Subgroups by Clock Sense

You can create subgroups using the **RISING** and **FALLING** keywords to group flip-flops triggered by rising and falling edges.

Clock Sense UCF Syntax Example One

```
TIMEGRP "group1"=RISING FFS;
```

```
TIMEGRP "group2"=RISING "ffs_group";
```

```
TIMEGRP "group3"=FALLING FFS;
```

```
TIMEGRP "group4"=FALLING "ffs_group";
```

where

- *group1* to *group4* are the new groups being defined.
- The *ffs_group* must be a group that includes only flip-flops.

Although keywords (such as **EXCEPT**, **RISING**, and **FALLING**) appear in the documentation in uppercase, you can enter them in either lowercase or uppercase. You cannot enter them in a combination of lowercase and uppercase.

Clock Sense UCF Syntax Example Two

The following example defines a group of flip-flops that switch on the falling edge of the clock.

```
TIMEGRP "falling_ffs"=FALLING FFS;
```

Defining Latch Subgroups by Gate Sense

Groups of type LATCHES (no matter how these groups are defined) can be easily separated into transparent **high** and transparent **low** subgroups. The **TRANSHI** and **TRANSLO** keywords are provided for this purpose and are used in TIMEGRP statements like the **RISING** and **FALLING** keywords for flip-flop groups.

Gate Sense UCF Syntax Example One

```
TIMEGRP "lowgroup"=TRANSLO "latchgroup";  
TIMEGRP "highgroup"=TRANSHI "latchgroup";
```

Creating Groups by Pattern Matching

When creating groups, you can use wildcard characters to define groups of symbols whose associated net names match a specific pattern. This is typically used in schematic designs where net names are specified, not instance names. Synthesis plans typically use INST/TNM syntax. For more information, see [Timing Name \(TNM\)](#).

Using Wildcards to Specify Net Names

The following wildcard characters enable you to select a group of symbols whose output net names match a specific string or pattern:

- Asterisk *
- Represents any string of zero or more characters
- Question mark ?
- Represents a single character

For example:

- **DATA*** specifies any net name that begins with **DATA**, such as:
 - **DATA**
 - **DATA1**
 - **DATA22**
 - **DATABASE**
- **NUMBER?** specifies any net name that begins with **NUMBER** and ends with one single character, such as:
 - **NUMBER1**
 - **NUMBERS**
 - *but not*
 - ◆ **NUMBER**
 - ◆ **NUMBER12**

You can also specify more than one wildcard character. For example:

- ***AT?** specifies any net name that:
 - Begins with any series of characters followed by **AT**
 - Ends with any *one* character, such as
 - ◆ **BAT1**
 - ◆ **CAT2**
 - ◆ **THAT5**
- ***AT*** specifies any net name that:
 - Begins with any series of characters followed by **AT**
 - Ends with any series of characters, such as
 - ◆ **BAT11**
 - ◆ **CAT26**
 - ◆ **THAT50**

Wildcards UCF Syntax Example One

The syntax for creating a group using pattern matching is:

```
TIMEGRP "group_name"=predefined_group("pattern");
```

where

- *predefined_group* can be one of the following predefined groups only:
 - **FF**
 - **LATCH**
 - **PAD**
 - **RAM**
 - **HSIOS**
 - **DSP**
 - **BRAM_PORTA**
 - **BRAM_PORTB**
 - **MULT**

For the definitions of these groups, see *UCF and NCF Syntax* in [Timing Name Net \(TNM_NET\)](#).

Note The use of the predefined type **MULTS** would not be correct if multipliers are not available in the architecture.

- *pattern* is any string of characters used in conjunction with one or more wildcard characters.

When specifying a net name, you must use its full hierarchical path name so PAR can find the net in the flattened design.

- For the following, specify the output net name:
 - FF
 - RAM
 - LATCH
 - PAD
 - CPU
 - DSP
 - HSIOS
 - MULT
- For pads, specify the external net name.

Wildcards UCF Syntax Example Two

The following example illustrates a group that includes the flip-flops that source nets whose names begin with \$1I3/FRED.

```
TIMEGRP "group1"=FFS("$1I3/FRED*");
```

Wildcards UCF Syntax Example Three

The following example illustrates a group that excludes certain flip-flops whose output net names match the specified pattern.

```
TIMEGRP "this_group"=FFS EXCEPT FFS("a*");
```

where

this_group includes all flip-flops except those whose output net names begin with the letter

Wildcards UCF Syntax Example Four

The following example defines a group named *some_latches*.

```
TIMEGRP "some_latches"=latches("$1I3/xyz*");
```

where

the group *some_latches* contains all input latches whose output net names start with \$1I3/xyz.

Additional Pattern Matching Information

In addition to using pattern matching when you create timing groups, you can specify a predefined group qualified by a pattern any place you specify a predefined group. The syntax below illustrates how pattern matching can be used within a timing specification.

Pattern Matching UCF Syntax Example One

```
TIMESPEC "TSidentifier"=FROM predefined_group("pattern") TO  
predefined_group("pattern") value;
```

Pattern Matching UCF Syntax Example Two

Instead of specifying one pattern, you can specify a list of patterns separated by a colon.

```
TIMEGRP "some_ffs"=FFS("a*:b?:c*d");
```

where

The group *some_ffs* contains flip-flops whose output net names adhere to one of the rules shown in the following table.

Pattern	Meaning
a*	Starts with a
b?	Contains two characters, the first of which is b
c*d	Starts with c and ends with d

Defining Area Groups Using Timing Groups

For more information, see *Defining From Timing Groups* in the [Area Group \(AREA_GROUP\)](#) constraint.

Timing Groups UCF Syntax Example One

```
TIMEGRP "newgroup"="existing_grp1" "existing_grp2" ["existing_grp3" ...];
```

where

newgroup is a newly created group that consists of:

- existing groups created via TNMs
- predefined groups
- other TIMEGRP attributes

Timing Groups UCF Syntax Example Two

```
TIMEGRP "GROUP1" = "gr2" "GROUP3";
```

```
TIMEGRP "GROUP3" = FFS except "grp5";
```

XCF Syntax

XST supports TIMEGRP with the following limitations:

- Groups Creation by Exclusion is not supported
- When a group is defined on the basis of another user group with pattern matching:
 - TIMEGRP TG1 = FFS (**machine***);
Supported
 - TIMEGRP TG2 = TG1 (**machine_clk1***);
Not supported

Constraints Editor Syntax

For information on Constraints Editor and Constraints Editor syntax in ISE® Design Suite, see the ISE Design Suite Help.

PlanAhead Syntax

For more information about using the PlanAhead software to create constraints, see *Floorplanning the Design* in the *PlanAhead User Guide (UG632)*. See [PlanAhead](#) in this Guide for information about:

- Defining placement constraints
- Assigning placement constraints
- Defining I/O pin configurations
- Floorplanning and placement constraints

PCF Syntax**TIMEGRP** *name*;**TIMEGRP** *name* = *list of elements*;

TIMESPEC (Timing Specifications)

The TIMESPEC (Timing Specifications) constraint:

- Is a basic timing related constraint
- Serves as a placeholder for timing specifications, which are called **TS** attribute definitions.

Every **TS** attribute:

- Begins with the letters **TS**
- Ends with a unique identifier that can consist of:
 - letters
 - numbers
 - the underscore character (`_`)

Architecture Support

Applies to all FPGA devices and all CPLD devices.

Applicable Elements

TS identifiers

Propagation Rules

Not applicable.

Constraint Syntax

The *value* parameter defines the maximum delay for the attribute. Nanoseconds are the default units for specifying delay time in TS attributes. You can also specify delay using other units, such as picoseconds or megahertz.

Keywords, such as **FROM**, **TO**, and **TS**, appear in the documentation in uppercase. However, you can enter them in the TIMESPEC primitive in either uppercase or lowercase. The characters in the keywords must be all uppercase or all lowercase. Examples of acceptable keywords are:

- **FROM**
- **PERIOD**
- **TO**
- **from**
- **to**

Examples of unacceptable keywords are:

- **From**
- **To**
- **fRoM**
- **tO**

TSidentifier name

If a TSidentifier name is referenced in a property value, it must be entered in uppercase letters. For example, the **TSID1** in the second constraint below must be entered in uppercase letters to match the **TSID1** name in the first constraint.

```
TIMESPEC "TSID1" = FROM "gr1" TO "gr2" 50;  
TIMESPEC "TSMAIN" = FROM "here" TO "there" TSID1 /2;
```

Separators

A colon may be used as a separator instead of a space in all timing specifications.

FROM-TO Syntax

Use the following User Constraints File (UCF) syntax to specify timing requirements between specific end points.

```
TIMESPEC "TSidentifier"=FROM "source_group" TO "dest_group" value units;
```

```
TIMESPEC "TSidentifier"=FROM "source_group" value units;
```

```
TIMESPEC "TSidentifier"=TO "dest_group" value units;
```

Unspecified **FROM** or **TO**, as in the second and third syntax statements, implies all points.

Note Although you can use a **FROM** or **TO** statement to imply all points, you cannot use an unspecified **THRU** statement by itself to imply all points.

The **From-To** statements are **TS** attributes that reside in the **TIMESPEC** primitive. The parameters *source_group* and *dest_group* must be one of the following:

- Predefined groups
- Previously created TNM identifiers
- Groups defined in TIMEGRP symbols
- TPSYNC groups

Predefined groups consist of:

- **FF**
- **LATCH**
- **RAM**
- **PAD**
- **CPU**
- **DSP**
- **HSIO**
- **BRAM_PORTA**
- **BRAM_PORTB**
- **MULT**

These groups are defined in the UCF and NCF Syntax section in the [TNM_NET](#) constraint, and are discussed in [Grouping Constraints](#) of the Constraints Type chapter.

Keywords, such as **FROM**, **TO**, and **TS** appear in the documentation in uppercase. However, you use them in **TIMESPEC** in either uppercase or lowercase. You cannot enter them in a combination of lowercase and uppercase.

The *value* parameter defines the maximum delay for the attribute. Nanoseconds are the default units for specifying delay time in **TS** attributes. You can also specify delay using other units, such as picoseconds or megahertz.

Syntax Examples

The following examples show how to use this constraint with particular tools or methods. If a tool or method is not listed, you cannot use this constraint with it.

TIMESPEC Examples of FROM-TO TS Attributes

UCF and NCF Syntax -

```
TIMESPEC "TS_master"=PERIOD "master_clk" 50 HIGH 30;
```

```
TIMESPEC "TS_THIS"=FROM FFS TO RAMS 35;
```

```
TIMESPEC "TS_THAT"=FROM PADS TO LATCHES 35;
```

UCF Syntax Examples

A **TS** attribute defines the allowable delay for paths in your design. The basic syntax for a **TS** attribute is:

```
TIMESPEC "TSidentifier"=PERIOD "timegroup_name" value [units];
```

where

- *TSidentifier* is a unique name for the TS attribute
- *value* is a numerical value
- *units* can be ms, micro, ps, ns

```
TIMESPEC "TSidentifier"=PERIOD "timegroup_name" "TSidentifier" [* or /] factor PHASE [+ |-] phase_value [units];
```

Constraints Editor Syntax

For information on setting constraints in Constraints Editor, including syntax, see the Constraints Editor Help.

PlanAhead Syntax

For more information about using the PlanAhead software to create constraints, see *Floorplanning the Design* in the *PlanAhead User Guide (UG632)*. See [PlanAhead](#) in this Guide for information about:

- Defining placement constraints
- Assigning placement constraints
- Defining I/O pin configurations
- Floorplanning and placement constraints

TNM (Timing Name)

TNM (Timing Name) is a basic grouping constraint. Use TNM to identify the elements that make up a group which you can then use in a timing specification.

TNM tags specific **FF**, **RAM**, **LATCH**, **PAD**, **CPU**, **HSIOS** and **MULT** elements as members of a group to simplify the application of timing specifications to the group.

The **RISING** and **FALLING** keywords may also be used with TNM.

A TNM based upon a **PAD** name that is associated with a Partition is not supported. A TNM based upon a net name within a Partition is supported.

TNM and TNM_NET

Placing TNM on a net groups together flip-flops, latches, RAM, or pads driven by that net.

TNM *does not* propagate through IBUF or BUFG components. The TNM will end up on the input pad.

Alternatively, the TNM_NET attribute *does* propagate through IBUF and global clock buffers.

Xilinx® recommends:

- Use TNM to group instances and macros (hierarchical blocks)
- To group input pads, use a TNM on the net, driven by a pad.
- Use TNM_NET to group several (many) logic elements driven by a net, such as clocks, clock enables, chip enables, read/writes, and resets.

Architecture Support

Applies to all FPGA devices and all CPLD devices.

Applicable Elements

You can attach TNM to a net, an element pin, a primitive, or a macro.

You can attach TNM to the net connected to the pad component in a User Constraints File (UCF) file. NGCBuild transfers the constraint from the net to the pad instance in the NGDBuild file so that it can be processed by the mapper. Use the following UCF syntax:

```
NET "net_name" TNM="property_value";
```

Propagation Rules

When attached to a net or signal, TNM propagates to all synchronous elements and PADS driven by that net. No special propagation is required.

When attached to a design element, TNM propagates to all applicable elements in the hierarchy within the design element.

The following rules apply to TNM.

- TNM applied to pad nets does *not* propagate forward through IBUFs. The TNM is applied to the external pad. This case includes the net attached to the D input of an IFD. See [Timing Name Net \(TNM_NET\)](#) if you want the TNM to trace forward from an input pad net.
- TNM applied to an IBUF instance is illegal.
- TNM applied to the output pin of an IBUF propagates the TNM to the next appropriate element.
- TNM applied to an IBUF element stays attached to that element.
- TNM applied to a clock-pad-net does not propagate forward through the clock buffer.
- When TNM is applied to a macro, all the elements in the macro have that timing name.

Placing TNM on Nets

You can place TNM on any net in the design. The constraint indicates that the TNM value should be attached to all valid elements fed by all paths that fan forward from the tagged net. Forward tracing stops at FFS, RAMS, LATCHES, PADS, CPUS, HSIOS, and MULTS. TNM does not propagate across IBUFs if they are attached to the input pad net.

Placing TNM on Macro or Primitive Pins

You can place TNM on any component pin in the design if the design entry package allows placement of constraints on primitive pins. The constraint indicates that the TNM value should be attached to all valid elements fed by all paths that fan forward from the tagged pin. Forward tracing stops at FFS, RAMS, LATCHES, PADS, CPUS, HSIOS, and MULTS.

The syntax for the UCF file is:

```
PIN "pin_name" TNM="FLOPS";
```

Placing TNM on Primitive Symbols

You can group individual logic primitives explicitly by placing a constraint on each instance.

The flip-flops tagged with TNM form a group called FLOPS. The untagged flip-flops are not part of the group. See the UCF syntax example.

Place only one TNM on each symbol, driver pin, or macro driver pin.

UCF Syntax

```
INST "instance_name" TNM=FLOPS;
```

Placing TNM on Nets or Pins to Group Flip-Flops and Latches

You can easily group flip-flops, latches, or both by flagging a common input net, typically either a clock net or an enable net. If you attach a TNM to a net or driver pin, that TNM applies to all flip-flops and input latches that are reached through the net or pin. That is, that path is traced forward, through any number of gates or buffers, until it reaches a flip-flop or input latch. That element is added to the specified TNM group.

The TNM parameter on nets or pins is allowed to have a qualifier. For example, in UCF files:

```
{NET|PIN} "net_or_pin_name" TNM=FFS data;
{NET|PIN} "net_or_pin_name" TNM=RAMS fifo;
{NET|PIN} "net_or_pin_name" TNM=RAMS capture;
```

A qualified TNM is traced forward until it reaches the first storage element (FFS, RAMS, LATCHES, PADS, CPUS, HSIOs, and MULTS). If that type of storage element matches the qualifier, the storage element is given that TNM value. Whether or not there is a match, the TNM is *not* traced through that storage element.

TNM parameters on nets or pins are never traced through a storage element (FFS, RAMS, LATCHES, PADS, CPUS, HSIOs, and MULTS).

TNM Syntax

The following examples show how to use this constraint with particular tools or methods. If a tool or method is not listed, you cannot use this constraint with it.

UCF and NCF Syntax

```
{NET|INST|PIN} "net_or_pin_or_inst_name " TNM= [predefined_group] identifier;
```

where

- *predefined_group* can be:
 - All of the members of a predefined group using the keywords FFS, RAMS, LATCHES, PADS, CPUS, HSIOs, and MULTS as follows:
 - ◆ FFS refers to all CLB and IOB flip-flops. Flip-flops built from function generators are not included.
 - ◆ RAMS refers to all RAMs for architectures with RAMS. This includes LUT RAMS and BLOCK RAMS.
 - ◆ PADS refers to all I/O pads.
 - ◆ LATCHES refers to all CLB or IOB latches. Latches built from function generators are not included.
 - ◆ MULTS group the Spartan®-3, Spartan-3A, and Spartan-3E registered multiplier.
 - A subset of elements in a *predefined_group* can be defined as follows:

```
predefined_group (name_qualifier1... name_qualifiern)
```

where

*name_qualifier**n* can be any combination of letters, numbers, or underscores. The *name_qualifier* type (net or instance) is based on the element type that TNM is placed on. If the TNM is on a NET, the *name_qualifier* is a net name. If the TNM is an instance (INST), the *name_qualifier* is an instance name.

Example

```
NET clk TNM = FFS (my_flop) Grp1;
```

```
INST clk TNM = FFS (my_macro) Grp2;
```

- *identifier* can be any combination of letters, numbers, or underscores.

identifier cannot be any the following reserved words: FFS, RAMS, LATCHES, PADS, CPUS, HSIOs, MULTS, RISING, FALLING, TRANSHI, TRANSLO, or EXCEPT.

Do not use the reserved words in the table below as *identifier*.

Reserved Words (Constraints)

ADD	ALU	ASSIGN
BEL	BLKNM	CAP
CLKDV_DIVIDE	CLBNM	CMOS
CYMODE	DECODE	DEF
DIVIDE1_BY	DIVIDE2_BY	DOUBLE
DRIVE	DUTY_CYCLE_CORRECTION	FAST
FBKINV	FILE	F_SET
HBLKNM	HU_SET	H_SET
INIT	INIT OX	INTERNAL
IOB	IOSTANDARD	LIBVER
LOC	LOWPWR	MAP
MEDFAST	MEDSLOW	MINIM
NODELAY	OPT	OSC
RES	RLOC	RLOC_ORIGIN
RLOC_RANGE	SCHNM	SLOW
STARTUP_WAIT	SYSTEM	TNM
TRIM	TS	TTL
TYPE	USE_RLOC	U_SET

You can specify as many groups of end points as are necessary to describe the performance requirements of your design. However, to simplify the specification process and reduce the Place and Route (PAR) time, use as few groups as possible.

XCF Syntax

See *UCF and NCF Syntax* below.

Constraints Editor Syntax

For information on setting constraints in Constraints Editor, including syntax, see the Constraints Editor Help.

PlanAhead Syntax

For more information about using the PlanAhead software to create constraints, see *Floorplanning the Design* in the *PlanAhead User Guide (UG632)*. See [PlanAhead](#) in this Guide for information about:

- Defining placement constraints
- Assigning placement constraints
- Defining I/O pin configurations
- Floorplanning and placement constraints

TNM_NET (Timing Name Net)

The TNM_NET (Timing Name Net) constraint:

- Is a basic grouping constraint.
- Identifies the elements that make up a group, which can then be used in a timing specification.
- Is essentially equivalent to [Timing Name \(TNM\)](#) on a net *except* for input pad nets

Special rules apply when using [Timing Name \(TNM\)](#) with [Period \(PERIOD\)](#) for DLL, DCM, PLL, and MMCM. For more information, see [PERIOD Specifications on CLKDLLs, DCMs, PLLs, and MMCM](#).

A TNM_NET is a property normally used in conjunction with an HDL design to tag a specific net. All downstream synchronous elements and pads tagged with the TNM_NET identifier are considered a group.

TNM_NET tags specific synchronous elements, pads, and latches as members of a group to simplify the application of timing specifications to the group. NGCBuild never transfers a [Timing Name \(TNM\)](#) constraint from the attached net to an input pad, as it does with [Timing Name \(TNM\)](#).

TNM and TNM_NET

Placing TNM on a net groups together flip-flops, latches, RAM, or pads driven by that net.

TNM *does not* propagate through IBUF or BUFG components. The TNM will end up on the input pad.

Alternatively, the TNM_NET attribute *does* propagate through IBUF and global clock buffers.

Xilinx® recommends:

- Use TNM to group instances and macros (hierarchical blocks)
- To group input pads, use a TNM on the net, driven by a pad.
- Use TNM_NET to group several (many) logic elements driven by a net, such as clocks, clock enables, chip enables, read/writes, and resets.

Architecture Support

Applies to FPGA devices. Does not apply to CPLD devices.

Applicable Elements

Nets

Rules

The following rules apply to TNM_NET:

- TNM_NET constraints applied to pad nets propagate forward through the IBUF or OBUF and any other combinatorial logic to synchronous logic or pads.
- TNM_NET constraints applied to a clock-pad-net propagate forward through the clock buffer.
- Special rules apply when using TNM_NET with [Period \(PERIOD\)](#) for Virtex®-4 and Virtex-5 DLLs, DCMs, and PLLs.

Use TNM_NET to define certain types of nets that cannot be adequately described by the [Timing Name \(TNM\)](#) constraint.

For example, consider the following design

TNM Associated with the IPAD

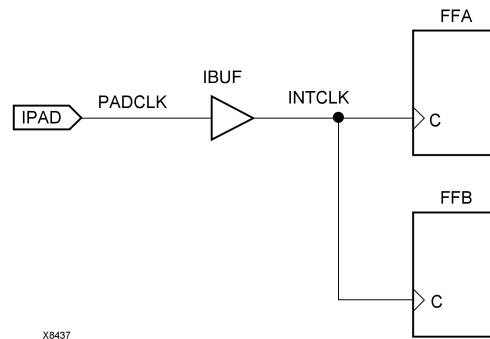

In the preceding design, a **Timing Name (TNM)** constraint associated with the IPAD symbol includes only the PAD symbol as a member in a timing analysis group. For example, the following UCF file entry creates a time group that includes the IPAD symbol only.

```
NET "PADCLK" TNM="PADGRP"; (UCF file example)
```

However, using **Timing Name (TNM)** to define a time group for the net PADCLK creates an empty time group.

```
NET "PADCLK" TNM=FFS "FFGRP";(UCF file example)
```

All properties that apply to a pad are transferred from the net to the PAD symbol. Since the TNM is transferred from the net to the PAD symbol, the qualifier, "FFS" does not match the PAD symbol.

To overcome this obstacle for schematic designs using **Timing Name (TNM)**, you can create a time group for the INTCLK net.

```
NET "INTCLK" TNM=FFS FFGRP;(UCF file example)
```

However, for HDL designs, the only meaningful net names are the ones connected directly to pads. Then, use TNM_NET to create the FFGRP time group.

```
NET PADCLK TNM_NET=FFS FFGRP;(UCF file example)
```

NGDBuild does not transfer a TNM_NET constraint from a net to an IPAD as it does with TNM.

You can use TNM_NET in Netlist Constraints File (NCF) or User Constraints File (UCF) files as a property attached to a net in an input netlist (EDIF or NGC). TNM_NET is not supported in PCF files.

You can use TNM_NET with nets or instances. If TNM_NET is used with any other object such as a pin or symbol, a warning is generated and the TNM_NET definition is ignored.

Propagation Rules

It is illegal to attach TNM_NET to a design element.

Syntax Examples

The following examples show how to use this constraint with particular tools or methods. If a tool or method is not listed, you cannot use this constraint with it.

Schematic Syntax

- Attach to a net
- Attribute Name
TNM_NET
- Attribute Values **identifier**

For a list of the constraint values, see the *UCF and NCF Syntax* section below.

UCF and NCF Syntax

{NET|INST} "*net_name*" TNM_NET=[*predefined_group*:]*identifier*;

- *predefined_group* can be:
 - All of the members of a predefined group using the following keywords:
 - ◆ FF
 - ◆ LATCH
 - ◆ PAD
 - ◆ RAM
 - ◆ HSIO
 - ◆ DSP
 - ◆ BRAM_PORTA
 - ◆ BRAM_PORTB
 - ◆ MULT
 - ◆ FFS refers to all CLB and IOB flip-flops. Flip-flops built from function generators are not included.
 - ◆ RAMS refers to all RAMs for architectures with RAMS. This includes LUT RAMS and BLOCK RAMS.
 - ◆ PADS refers to all I/O pads.
 - ◆ MULTS group the Spartan®-3, Spartan-3A, and Spartan-3E registered multiplier.
 - ◆ DSPS is used to group DSP elements like the Virtex-4 DSP48.
 - ◆ LATCHES refers to all CLB or IOB latches. Latches built from function generators are not included.
 - A subset of elements in a *predefined_group* can be defined as follows:
predefined_group (*name_qualifier*1... *name_qualifier**n*)
where
*name_qualifier**n* can be any combination of letters, numbers, or underscores. The *name_qualifier* type (net or instance) is based on the element type that TNM_NET is placed on. If the TNM_NET is on a NET, the *name_qualifier* is a net name. If the TNM_NET is an instance (INST), the *name_qualifier* is an instance name.
Example
NET clk TNM_NET = FFS (my_flop) Grp1;
INST clk TNM_NET = FFS (my_macro) Grp2;
- *identifier* can be any combination of letters, numbers, or underscores.

The *identifier* cannot be any the following reserved words: FFS, RAMS, LATCHES, PADS, CPUS, HSIO, MULTS, RISING, FALLING, TRANSHI, TRANSLO, or EXCEPT.

In addition, do not use the reserved words shown in the [TNM \(Timing Name\) constraint Reserved Words](#) table as *identifier*.

The following statement identifies all flip-flops fanning out from the PADCLK net as a member of the timing group GRP1.

```
NET "PADCLK" TNM_NET=FFS "GRP1";
```

XCF Syntax

XST supports TNM_NET with the following limitation: only a single pattern supported for predefined groups.

The following command syntax is supported:

```
NET "PADCLK" TNM_NET=FFS "GRP1";
```

The following command syntax is *not* supported:

```
NET "PADCLK" TNM_NET = FFS(machine/*:xcounter/*) TG1;
```

Constraints Editor Syntax

For information on setting constraints in Constraints Editor, including syntax, see the Constraints Editor Help.

PlanAhead™ Syntax

For more information about using the PlanAhead software to create constraints, see *Floorplanning the Design* in the *PlanAhead User Guide (UG632)*. See [PlanAhead](#) in this Guide for information about:

- Defining placement constraints
- Assigning placement constraints
- Defining I/O pin configurations
- Floorplanning and placement constraints

TPSYNC (Timing Point Synchronization)

The TPSYNC (Timing Point Synchronization) constraint:

- Is a grouping constraint.
- Flags a particular point or a set of points with an identifier for use in subsequent timing specifications. If you use the same identifier on several points, timing analysis treats the points as a group

Architecture Support

Applies to FPGA devices. Does not apply to CPLD devices.

Applicable Elements

- Nets
- Instances
- Pins

Propagation Rules

When the timing of a design must be designed from or to a point that is not a synchronous element or I/O pad, the following rules apply if a TPSYNC timing point is attached to any of the following.

- Net
The source of the net is identified as a potential source or destination for timing specifications.
- Macro pin
All of the sources inside the macro that drive the pin to which the constraint is attached are identified as potential sources or destinations for timing specifications. If the macro pin is an input pin (that is, if there are no sources for the pin in the macro), then all of the load pins in the macro are flagged as synchronous points.
- The output pin of a primitive
The output is flagged as a potential source or destination for timing specifications.
- The input pin of a primitive
The input of the primitive is flagged as a potential source or destination for timing specifications.
- An instance
The output of that element is identified as a potential source or destination for timing specifications.
- A primitive symbol
Attached to a primitive symbol, TPSYNC identifies the outputs of that element as a potential source or destination for timing specifications. See the following figure.

TPSYNC Attached to Macro Pins

POINTY applies to the inverter.

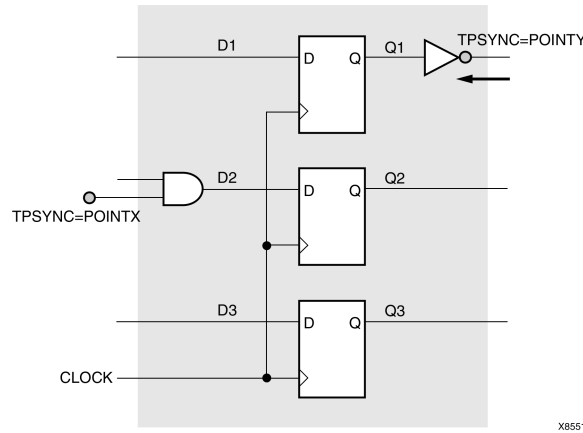

TPSYNC Attached to a Primitive Symbol

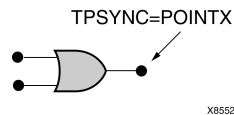

Working with Two Gates

Using a TPSYNC timing point to define a synchronous point in a design implies that the flagged point cannot be merged into a function generator. For example, in the following diagram, because of the TPSYNC definition, the two gates cannot be merged into a single function generator.

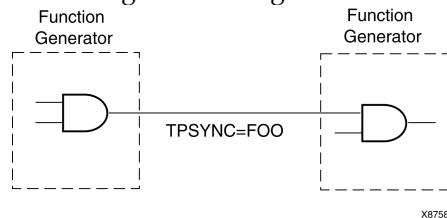

Syntax Examples

The following examples show how to use this constraint with particular tools or methods. If a tool or method is not listed, you cannot use this constraint with it.

Values

identifier is a name that is used in timing specifications in the same way that groups are used

Schematic Syntax

- Attached to a net, instance, or pin
- Attribute Name
TPSYNC
- Attribute Values

See *Values* section above.

UCF and NCF Syntax

```
NET "net_name" TPSYNC=identifier;
```

```
INST "instance_name" TPSYNC=identifier;
```

```
PIN "pin_name" TPSYNC=identifier;
```

All flagged points are used as a source or destination or both for the specification where the TPSYNC identifier is used.

The name for the identifier must be unique to any identifier used for a [TNM](#) or [TNM_NET](#) grouping constraint.

The following statement identifies latch as a potential source or destination for timing specifications for the net **logic_latch**.

```
NET "logic_latch" TPSYNC=latch;
```

Constraints Editor Syntax

For information on setting constraints in Constraints Editor, including syntax, see the Constraints Editor Help.

TPTHRU (Timing Thru Points)

The TPTHRU (Timing Thru Points) constraint:

- Is a grouping constraint.
- Flags a particular *point* or *set of points* with an identifier for reference in subsequent timing specifications.

Note If you use the same identifier on several points, timing analysis treats the points as a group. For more information, see [TIMESPEC \(Timing Specifications\)](#).

- Defines intermediate points on a path to which a specification applies. For more information, see [TSidentifier \(Timing Specification Identifier\)](#).

Architecture Support

Applies to FPGA devices. Does not apply to CPLD devices.

Applicable Elements

- Nets
- Pins
- Instances

Propagation Rules

Not applicable

Syntax Examples

The following examples show how to use this constraint with particular tools or methods. If a tool or method is not listed, you cannot use this constraint with it.

Schematic Syntax

- Attach to a net, instance, or pin
- Attribute Name
- Attribute Values

identifier

For more information, see *UCF and NCF Syntax* below.

UCF and NCF Syntax

```
NET "net_name" TPTHRU=identifier;
```

```
INST "instance_name" TPTHRU=identifier;
```

```
PIN "instance_name.pin_name" TPTHRU="thru_group_name";
```

where

identifier is used in timing specifications to further qualify timing paths within a design.

The identifier name must be different from any identifier used for a [TNM](#) constraint.

Using TPTHU in a FROM TO Constraint

It is sometimes convenient to define intermediate points on a path to which a specification applies. This defines the maximum allowable delay and has the syntax shown in the following sections.

UCF Syntax with TIMESPEC

```
TIMESPEC "TSidentifier"=FROM "source_group" THRU "thru_point" [THRU
"thru_point"] TO "dest_group" allowable_delay [units];
```

```
TIMESPEC "TSidentifier"=FROM "source_group" THRU "thru_point" [THRU
"thru_point"] allowable_delay [units];
```

where

- *identifier* is an ASCII string made up of the characters A..Z, a..z, 0..9, and underscore (`_`)
- *source_group* and *dest_group* are user-defined groups, predefined groups or TPSYNCS
- *thru_point* is an intermediate point used to qualify the path, defined using a TPTHU constraint
- *allowable_delay* is the timing requirement
- *units* is an optional field to indicate the units for the allowable delay. Default units are nanoseconds, but the timing number can be followed by ps, ns, micro, ms, GHz, MHz, or KHz to indicate the intended units.

The example shows how to use the TPTHU constraint with the THRU constraint on a schematic. The UCF syntax is as follows.

```
INST "FLOPA" TNM="A";
```

```
INST "FLOPB" TNM="B";
```

```
NET "MYNET" TPTHU="ABC";
```

```
TIMESPEC "TSpth1"=FROM "A" THRU "ABC" TO "B" 30;
```

The following statement identifies the net `on_the_way` as an intermediate point on a path to which the timing specification named `here` applies.

```
NET "on_the_way" TPTHU="here";
```

Note The following NCF construct is not supported.

```
TIMESPECT "TS_1"=THRU "Thru_grp" 30.0
```

Constraints Editor Syntax

For information on setting constraints in Constraints Editor, including syntax, see the Constraints Editor Help.

PCF Syntax

```
PATH "name"=FROM "source" THRU "thru_pt1" THRU "thru_ptn" TO "destination";
```

You are not required to have a **FROM**, **THRU**, and **TO**. You can have almost any combination, such as:

- **FROM-TO**
- **FROM-THRU-TO**
- **THRU-TO**
- **TO**
- **FROM**
- **FROM-THRU-THRU-THRU-TO**
- **FROM-THRU**

There is no restriction on the number of **THRU** points. The source, **THRU** points, and destination can be a **net**, **bel**, **comp**, **macro**, **pin**, or **timegroup**.

TSidentifier (Timing Specification Identifier)

TSidentifier (Timing Specification Identifier) is a basic timing constraint. *TSidentifier* properties beginning with the letters **TS** are used with the **TIMESPEC** in a User Constraints File (UCF). The value of *TSidentifier* corresponds to a specific timing specification that can then be applied to paths in the design.

Architecture Support

Applies to all FPGA devices and all CPLD devices.

Applicable Elements

TIMESPEC keywords

Propagation Rules

It is illegal to attach *TSidentifier* to a net, signal, or design element.

Syntax Examples

The following examples show how to use this constraint with particular tools or methods. If a tool or method is not listed, you cannot use this constraint with it.

UCF and NCF Syntax

All the following syntax definitions use a space as a separator. The use of a colon as a separator is optional.

Defining a Maximum Allowable Delay

```
TIMESPEC "TSidentifier"=FROM "source_group" TO "dest_group" allowable_delay [units];
```

Defining Intermediate Points (UCF)

```
TIMESPEC "TSidentifier"=FROM "source_group" THRU "thru_point" [THRU "thru_point1" ... "thru_pointn"] TO "dest_group" allowable_delay [units];
```

where

- *identifier* is an ASCII string made up of the characters A-Z, a-z, 0-9, and _
- *source_group* and *dest_group* are user-defined or predefined groups
- *thru_point* is an intermediate point used to qualify the path, defined using a TPTHURU constraint
- *allowable_delay* is the timing requirement value
- *units* is an optional field to indicate the units for the allowable delay. The default units are nanoseconds (ns), but the timing number can be followed by ps, ns, micro, ms, GHz, MHz, or kHz to indicate the intended units.

Defining a Linked Specification

This allows you to link the timing number used in one specification to another specification.

```
TIMESPEC "TSidentifier"=FROM "source_group" TO "dest_group" another_TSid [/ | *] number;
```

where

- *identifier* is an ASCII string made up of the characters A-Z, a-z, 0-9, and _
- *source_group* and *dest_group* are user-defined or predefined groups
- *another_Tsid* is the name of another timespec
- *number* is a floating point number

Defining a Clock Period

This allows more complex derivative relationships to be defined as well as a simple clock period.

```
TIMESPEC "TSidentifier"=PERIOD "TNM_reference" value [units] [{HIGH | LOW}
[high_or_low_time [hi_lo_units]]] INPUT_JITTER value;
```

where

- *identifier* is a reference identifier with a unique name
- *TNM_reference* is the identifier name attached to a clock net (or a net in the clock path) using a TNM constraint
- *value* is the required clock period
- *units* is an optional field to indicate the units for the allowable delay. The default units are nanoseconds (ns), but the timing number can be followed by micro, ms, ps, ns, GHz, MHz, or kHz to indicate the intended units
- **HIGH** or **LOW** can be optionally specified to indicate whether the first pulse is to be High or Low
- *high_or_low_time* is the optional High or Low time, depending on the preceding keyword. If an actual time is specified, it must be less than the period. If no High or Low time is specified, the default duty cycle is 50 percent.
- *hi_lo_units* is an optional field to indicate the units for the duty cycle. The default is nanoseconds (ns), but the High or Low time number can be followed by ps, micro, ms, ns or % if the High or Low time is an actual time measurement.

Specifying Derived Clocks

```
TIMESPEC "TSidentifier"=PERIOD "TNM_reference" "another_PERIOD_identifier" [/ | *]
number [{HIGH | LOW} [high_or_low_time [hi_lo_units]]] INPUT_JITTER value;
```

where

- *TNM_reference* is the identifier name attached to a clock net (or a net in the clock path) using a TNM constraint
- *another_PERIOD_identifier* is the name of the identifier used on another period specification
- *number* is a floating point number
- **HIGH** or **LOW** can be optionally specified to indicate whether the first pulse is to be High or Low
- *high_or_low_time* is the optional High or Low time, depending on the preceding keyword. If an actual time is specified, it must be less than the period. If no High or Low time is specified, the default duty cycle is 50 percent.
- *hi_lo_units* is an optional field to indicate the units for the duty cycle. The default is nanoseconds (ns), but the High or Low time number can be followed by ps, micro, ms, or % if the High or Low time is an actual time measurement.

Ignoring Paths

Note This form is not supported for CPLD devices.

There are situations in which a path that exercises a certain net should be ignored because all paths through the net, instance, or instance pin are not important from a timing specification point of view.

```
TIMESPEC "TSidentifier"=FROM "source_group" TO "dest_group" TIG;
```

or

```
TIMESPEC "TSidentifier"=FROM "source_group" THRU "thru_point" [THRU  
"thru_point1" ... "thru_pointn"] TO "dest_group" TIG;
```

where

- *identifier* is an ASCII string made up of the characters A-Z, a-z 0-9, and _
- *source_group* and *dest_group* are user-defined or predefined groups
- *thru_point* is an intermediate point used to qualify the path, defined using a TPTHRU constraint

The following statement says that the timing specification **TS_35** calls for a maximum allowable delay of 50 ns between the groups **here** and **there**.

```
TIMESPEC "TS_35"=FROM "here" TO "there" 50;
```

The following statement says that the timing specification **TS_70** calls for a 25 ns clock period for **clock_a**, with the first pulse being **High** for a duration of 15 ns.

```
TIMESPEC "TS_70"=PERIOD "clock_a" 25 high 15;
```

For more information, see [Logical Constraints](#) and [Physical Constraints in Chapter 2](#), "Constraint Types."

Constraints Editor Syntax

For information on setting constraints in Constraints Editor, including syntax, see the Constraints Editor Help.

Clock period constraints are entered using the Clock Domains entry. Input setup time is entered using the Inputs entry. Clock-to-output delay is entered using the Outputs entry. Pad-to-pad delays are entered using the **Exceptions > Paths** category.

PCF Syntax

The same as the UCF syntax without the **TIMESPEC** keyword.

FPGA Editor Syntax

For information on setting constraints in FPGA Editor, including syntax, see the FPGA Editor Help.

U SET (U_SET)

The U_SET (U SET) constraint:

- Is an advanced mapping constraint.
- Groups design elements with attached [RLOC](#) constraints that are distributed throughout the design hierarchy into a single set.

The elements that are members of a U_SET can cross the design hierarchy. You can arbitrarily select objects without regard to the design hierarchy and tag them as members of a U_SET. For more information, see [RLOC Sets](#).

Architecture Support

Applies to FPGA devices. Does not apply to CPLD devices.

Applicable Elements

This constraint may be used with an FPGA device in one or more of the following design elements, or categories of design elements. Not all devices support all elements. To see which design elements can be used with which devices, see the Libraries Guides. For more information, see the device data sheet.

- Registers
- Macro Instance
- **FMAP**
- **ROM**
- **RAMS**
- **RAMD**
- **BUFT**
- **MULT18X18S**
- **RAMB4_Sm_Sn**
- **RAMB4_Sn**
- **RAMB16_Sm_Sn**
- **RAMB16_Sn**
- **RAMB16**
- **DSP48**

Propagation Rules

This constraint is a macro constraint. Any attachment to a net is illegal.

Syntax Examples

The following examples show how to use this constraint with particular tools or methods. If a tool or method is not listed, you cannot use this constraint with it.

Schematic Syntax

- Attach to a valid instance
- Attribute Name: **U_SET**
- Attribute Values: **name**

where

name is the identifier of the set

VHDL Syntax

Declare the VHDL constraint as follows:

```
attribute U_SET: string;
```

Specify the VHDL constraint as follows:

```
attribute U_SET of {component_name | label_name}: {component | label} is name;
```

where

name is the identifier of the set

For more information about basic VHDL syntax, see [VHDL Attributes](#).

Verilog Syntax

Place the Verilog constraint immediately before the module or instantiation.

Specify the Verilog constraint as follows:

```
(* U_SET = name *)
```

where

name is the identifier of the set

For more information about basic Verilog syntax, see [Verilog Attributes](#).

UCF and NCF Syntax

```
INST "instance_name" U_SET= name;
```

where

name is the identifier of the set

This *name* is absolute. It is not prefixed by a hierarchical qualifier.

The following statement specifies that the design element **ELEM_1** be in a set called **JET_SET**.

```
INST "$1I3245/ELEM_1" U_SET=JET_SET;
```

XCF Syntax

```
BEGIN MODEL entity_name
```

```
INST "instance_name" U_SET=uset_name;
```

```
END;
```

Use Internal VREF (USE_INTERNAL_VREF)

The Use Internal Vref (USE_INTERNAL_VREF) constraint:

- Provides a means of assigning a voltage value to the internal Vref feature for a given IO bank.
- Frees the Vref pins of IO banks from their function of providing a voltage reference.
- Allows you to specify the Vref pins for either Vref or an alternative use.

Architecture Support

Applies to Virtex®-6 devices only.

Applicable Elements

This constraint can be specified for an instance, comp or net.

Propagation Rules

USE_INTERNAL_VREF is illegal when attached to a net except when the net is connected to a pad. In this case, USE_INTERNAL_VREF is treated as attached to the pad instance. When attached to a design element, USE_INTERNAL_VREF applies to the entity to which it is attached.

Syntax Examples

The following examples show how to use this constraint with particular tools or methods. If a tool or method is not listed, you cannot use this constraint with it.

Values

- **TRUE**
Turns *on* the constraint for a specific element
- **FALSE**
Turns *off* the constraint for a specific element
- **DONT_CARE**
Allows the tools to determine the use of the Vref pin

Schematic Syntax

- Attribute Name
USE_INTERNAL_VREF
- Attribute Values
See *Values* section above.

Verilog Syntax

Place the Verilog constraint immediately before the module or instantiation.

Specify the Verilog constraint as follows:

```
(* USE_INTERNAL_VREF = "{TRUE|FALSE|DONT_CARE}" *)
```

The default is **DONT_CARE**.

For more information about basic Verilog syntax, see [Verilog Attributes](#).

UCF and NCF Syntax

```
INST "instance_name" USE_INTERNAL_VREF={TRUE|FALSE|DONT_CARE};
```

The default is **TRUE**.

XCF Syntax

```
MODEL "entity_name" use_internal_vref ={true|false|dont_care}
```

The default is **TRUE**.

USE_LUTNM (Use LUTNM)

The USE_LUTNM (Use LUTNM) constraint:

- Is an advanced mapping and placement constraint.
- Turns [LUTNM \(Lookup Table Name\)](#) on or off for a specific element or section of a set.

Architecture Support

Applies to FPGA devices. Does not apply to CPLD devices.

Applicable Elements

Applies to instances or macros that are members of sets.

Propagation Rules

It is illegal to attach USE_LUTNM to a net.

Syntax Examples

The following examples show how to use this constraint with particular tools or methods. If a tool or method is not listed, you cannot use this constraint with it.

Values

- **TRUE**
Turns *on* the constraint for a specific element
- **FALSE**
Turns *off* the constraint for a specific element

The default is **TRUE**.

Schematic Syntax

- Attach to a member of a set
- Attribute Name
USE_LUTNM
- Attribute Values
See *Values* section above.

VHDL Syntax

Declare the VHDL constraint as follows:

```
attribute USE_LUTNM: string;
```

Specify the VHDL constraint as follows:

```
attribute USE_LUTNM of entity_name: entity is "{TRUE|FALSE}";
```

For more information about basic VHDL syntax, see [VHDL Attributes](#).

Verilog Syntax

Place the Verilog constraint immediately before the module or instantiation.

Specify the Verilog constraint as follows:

```
(* USE_LUTNM = "{TRUE|FALSE}" *)
```

For more information about basic Verilog syntax, see [Verilog Attributes](#).

UCF and NCF Syntax

```
INST "instance_name" USE_LUTNM={TRUE|FALSE};
```

XCF Syntax

```
MODEL "entity_name" use_lutnm={true|false};
```

USE_RLOC (Use Relative Location)

The USE_RLOC (Use Relative Location) constraint:

- Is an advanced mapping and placement constraint.
- Turns **RLOC** on or off for a specific element or section of a set.

Architecture Support

Applies to FPGA devices. Does not apply to CPLD devices.

Applicable Elements

Applies to instances or macros that are members of sets.

Propagation Rules

It is illegal to attach USE_RLOC to a net. When attached to a design element, U_SET propagates to all applicable elements in the hierarchy within the design element.

Using the USE_RLOC Constraint to Control RLOC Application on H_SET and HU_SET Sets

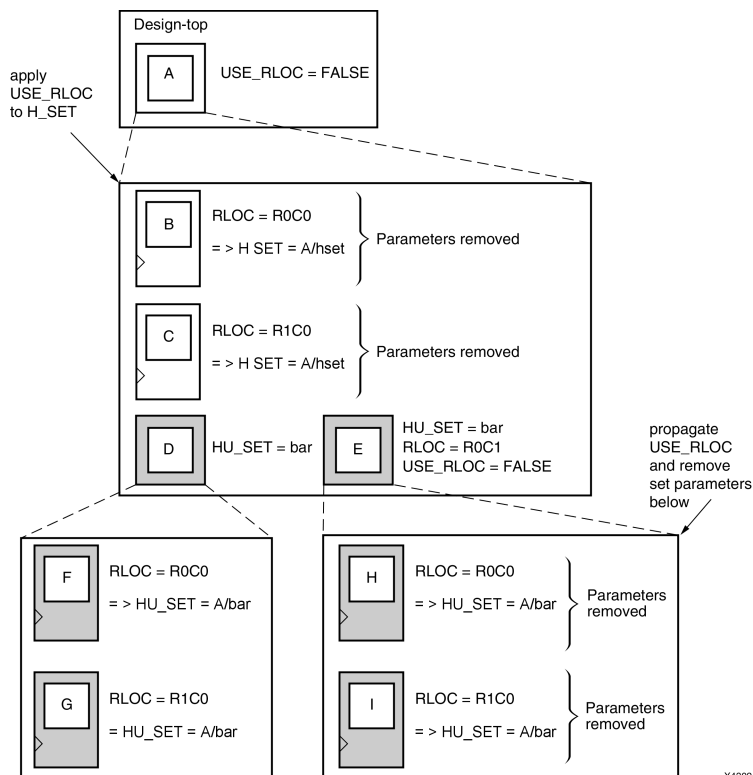

Applying USE_RLOC on **U_SET** sets is a special case because of the lack of hierarchy in the U_SET set. Because USE_RLOC propagates strictly in a hierarchical manner, the members of a **U_SET** set that are in different parts of the design hierarchy must be tagged separately with USE_RLOC. No single USE_RLOC constraint is propagated to all the members of the set that lie in different parts of the hierarchy.

If you create a **U_SET** set through an instantiating macro, you can attach **USE_RLOC** to the instantiating macro to allow it to propagate hierarchically to all the members of the set.

You can create this instantiating macro by placing **U_SET** on a macro and letting the mapper propagate that constraint to every symbol with an **RLOC** constraint below it in the hierarchy.

Using the **USE_RLOC** Constraint to Control **RLOC** Application on **U_SET** Sets

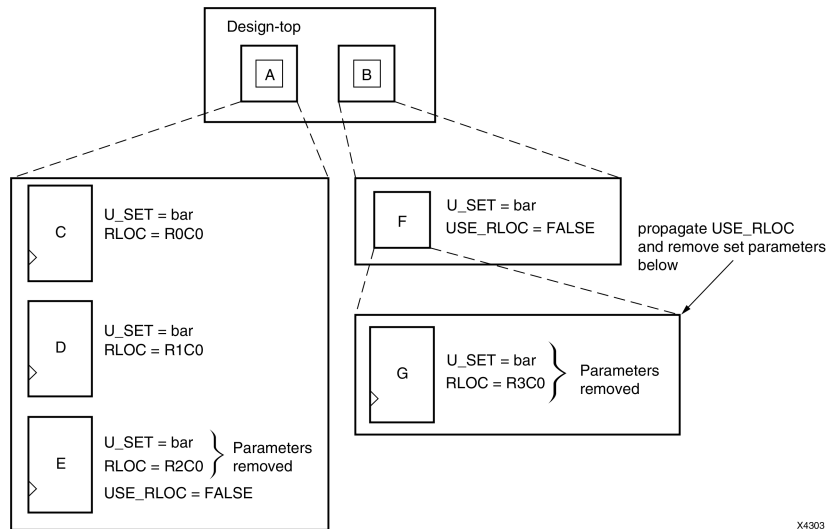

This illustration shows the use of **USE_RLOC=FALSE**. The **USE_RLOC=FALSE** on primitive **E** removes it from the **U_SET** set, and **USE_RLOC=FALSE** on element **F** propagates to primitive **G** and removes it from the **U_SET** set.

While propagating the **USE_RLOC** constraint, the mapper ignores underlying **USE_RLOC** constraints if it encounters elements higher in the hierarchy that already have **USE_RLOC** constraints. For example, if the mapper encounters an underlying element with a **USE_RLOC=TRUE** during the propagation of a **USE_RLOC=FALSE**, it ignores the newly encountered **TRUE** constraint.

Syntax Examples

The following examples show how to use this constraint with particular tools or methods. If a tool or method is not listed, you cannot use this constraint with it.

Values

- **TRUE** (default) turns **RLOC** on for a specific element
- **FALSE** turns **RLOC** off for a specific element

Schematic Syntax

- Attach to a member of a set
- Attribute Name
USE_RLOC
- Attribute Values

See *Values* section above.

VHDL Syntax

Declare the VHDL constraint as follows:

```
attribute USE_RLOC: string;
```

Specify the VHDL constraint as follows:

```
attribute USE_RLOC of entity_name: entity is "{TRUE | FALSE}";
```

For more information about basic VHDL syntax, see [VHDL Attributes](#).

Verilog Syntax

Place the Verilog constraint immediately before the module or instantiation.

Specify the Verilog constraint as follows:

```
(* USE_RLOC = "{TRUE|FALSE}" *)
```

For more information about basic Verilog syntax, see [Verilog Attributes](#).

UCF and NCF Syntax

```
INST "instance_name" USE_RLOC={TRUE | FALSE};
```

XCF Syntax

```
MODEL "entity_name" use_rloc={true | false};
```

Use Low Skew Lines (USELOWSKEWLINES)

The Use Low Skew Lines (USELOWSKEWLINES) constraint:

- Is a PAR routing constraint.
- Specifies the use of low skew routing resources for any net. You can use these resources for both internally generated and externally generated signals.

Externally generated signals are those driven by IOBs. USELOWSKEWLINES on a net directs PAR to route the net on one of the low skew resources. When this constraint is used, the timing tool automatically accounts for and reports skew on register-to-register paths that utilize those low skew resources. Specify USELOWSKEWLINES only when all four primary global clocks have been used.

Architecture Support

Applies to Virtex®-4 devices and higher and to Spartan®-3 devices and higher.

Applicable Elements

Nets

Propagation Rules

Applies to attached net

Syntax Examples

The following examples show how to use this constraint with particular tools or methods. If a tool or method is not listed, you cannot use this constraint with it.

Values

- YES
- NO
- TRUE
- FALSE

Schematic Syntax

- Attach to an output net
- Attribute Name
USELOWSKEWLINES
- Attribute Values
 - TRUE
 - FALSE

VHDL Syntax

Declare the VHDL constraint as follows:

```
attribute USELOWSKEWLINES: string;
```

Specify the VHDL constraint as follows:

```
attribute USELOWSKEWLINES of signal_name: signal is "{YES|NO|TRUE|FALSE}";
```

For more information about basic VHDL syntax, see [VHDL Attributes](#).

Verilog Syntax

Place the Verilog constraint immediately before the module or instantiation.

Specify the Verilog constraint as follows:

```
(* USELOWSKEWLINES = "{YES|NO|TRUE|FALSE}" *)
```

For more information about basic Verilog syntax, see [Verilog Attributes](#).

UCF and NCF Syntax

This statement forces **net \$1I87/1N6745** to be routed on one of the device's low skew resources.

```
NET "$1I87/$1N6745" USELOWSKEWLINES;
```

XCF Syntax

```
BEGIN MODEL "entity_name"
```

```
NET "signal_name" uselowskewlines={yes|true};
```

```
END;
```

Constraints Editor Syntax

For information on setting constraints in Constraints Editor, including syntax, see the Constraints Editor Help.

PCF Syntax

Same as *UCF and NCF Syntax* above.

VCCAUX (VCCAUX)

The VCCAUX (VCCAUX) constraint:

- Defines the voltage value of the VCCAUX pin for Spartan®-3A and Spartan-6 devices.
- Affects the banking rules for I/O placement within the automated placer, as well as in the PACE pin assignments software.
- Affects the end-generated bitstream for the device.

Architecture Support

Applies to Spartan-3A and Spartan-6 devices.

Applicable Elements

VCCAUX is a global attribute for Spartan-3A and Spartan-6 devices and is not attached to any particular element.

Syntax Examples

The following examples show how to use this constraint with particular tools or methods. If a tool or method is not listed, you cannot use this constraint with it.

Values

- 2.5
- 3.3

UCF and NCF Syntax

```
CONFIG VCCAUX="value";
```

Example

```
CONFIG VCCAUX=3.3;
```

VCCAUX_IO

The auxiliary I/O (VCCAUX_IO) supply rail is specific to the HP I/O banks only. It is used to power some of the I/O circuitry in the HP bank, including the single-ended and differential input buffer circuits. HP I/O banks contain both VCCAUX_IO pins, as well as the "regular" VCCAUX pins which power the various internal block features. Inside the 7 series device packages, the VCCAUX_IO pins are connected together in groups of three to four I/O banks. The number of I/O banks that have their VCCAUX_IO pins grouped together depends on the particular 7 series part and package combination. See the *7 Series Packaging and Pinout Guide* for banks that are grouped together for each part and package combination. The VCCAUX and VCCAUX_IO supplies must turn on before the VCCO supply. See the *7 Series FPGA Data Sheet* for more details regarding power supply requirements.

Architecture Support

Applies to Kintex™-7 and Virtex®-7 devices

Applicable Elements

See the *SelectIO™ User Guide*.

Propagation Rules

See the *SelectIO User Guide*.

Syntax

The following sections show the syntax for this constraint.

Syntax Examples

The following examples show how to use this constraint with particular tools or methods. If a tool or method is not listed, you cannot use this constraint with it.

Schematic Syntax

Attribute Name: VCCAUX_IO

VHDL Syntax

Declare the VHDL constraint as follows:

```
attribute VCCAUX_IO: string;
```

Specify the VHDL constraint as follows:

```
attribute VCCAUX_IO of {component_name |label_name}: {component|label} is  
"{{NORMAL|HIGH|DONTCARE}}";
```

For more information about basic VHDL syntax, see [VHDL Attributes](#).

Verilog Syntax

Place the Verilog constraint immediately before the module or instantiation.

Specify the Verilog constraint as follows:

```
(* VCCAUX_IO = { NORMAL|HIGH|DONTCARE} *)
```

For more information about basic Verilog syntax, see [Verilog Attributes](#).

UCF and NCF Syntax

```
NET "net_name" VCCAUX_IO=(0| NORMAL|HIGH|DONTCARE);  
INST "instance_name" VCCAUX_IO=( NORMAL|HIGH|DONTCARE);
```

VOLTAGE (Voltage)

The VOLTAGE (Voltage) constraint:

- Is a timing constraint.
- Allows the specification of the operating voltage, which provides a means of prorating delay characteristics based on the specified voltage.

Prorating is a scaling operation on existing speed file delays and is applied globally to all delays.

Note Newer devices may not support VOLTAGE prorating until the timing information (speed files) are marked as production status.

Each architecture has its own specific range of supported voltages. If the entered voltage does not fall within the supported range, the constraint is ignored and an architecture-specific default value is used instead. The error message for this condition appears during static timing.

Architecture Support

The following FPGA devices are supported for VOLTAGE:

- Spartan®-3A
- Spartan-3E
- Virtex®-4
- Virtex-5

Applicable Elements

Applies globally to the entire design.

Propagation Rules

It is illegal to attach this constraint to a net, signal, or design element.

Syntax Examples

The following examples show how to use this constraint with particular tools or methods. If a tool or method is not listed, you cannot use this constraint with it.

UCF and NCF Syntax

VOLTAGE=*value* [V];

where

- *value* is a real number specifying the voltage
- *V* indicates volts, the default voltage unit

The following statement specifies that the analysis for everything relating to speed file delays assumes an operating power of 5 volts.

VOLTAGE=5 ;

Constraints Editor Syntax

For information on setting constraints in Constraints Editor, including syntax, see the Constraints Editor Help.

PCF Syntax

Same as UCF Syntax.

VREF (VREF)

The VREF (VREF) constraint:

- Applies to the design as a global attribute (not directly applicable to any element in the design).
- Configures listed pins as VREF supply pins to be used in conjunction with other I/O pins designated with one of the SSTL or HSTL I/O Standards.

Because VREF is selectable on any I/O in CoolRunner™-II designs, it allows you to select which pins are VREF pins. Double-check pin assignment in the report (RPT) file. If you do not specify any VREF pins for the differential I/O standards, HSTL and SSTL, or if you do not specify sufficient VREF pins within the required proximity of differential I/O pins, the fitter automatically assigns sufficient VREF.

Architecture Support

Applies only to CoolRunner-II devices with 128 macrocells and larger.

Applicable Elements

Applies globally to the entire design.

Propagation Rules

Configures listed pins as VREF supply pins to be used in conjunction with other I/O pins designated with one of the SSTL or HSTL I/O Standards.

Syntax Examples

The following examples show how to use this constraint with particular tools or methods. If a tool or method is not listed, you cannot use this constraint with it.

Values

- P_{mn}
where
 m is a numeric pin number
- rc
where
 - r =alphabetic row
 - c =numeric column

Schematic Syntax

VREF=*value_list* (on CONFIG symbol)

UCF and NCF Syntax

CONFIG VREF=*value_list*;

CONFIG VREF=P12,P13;

WIREAND (Wire And)

The WIREAND (Wire And) constraint:

- Is an advanced fitter constraint
- Forces a tagged node to be implemented as a wired **AND** function in the interconnect (UIM and **Fastconnect**)

Architecture Support

Applies to XC9500 devices only.

Applicable Elements

Any net

Propagation Rules

This constraint is a net constraint. Any attachment to a design element is illegal.

Syntax Examples

The following examples show how to use this constraint with particular tools or methods. If a tool or method is not listed, you cannot use this constraint with it.

Schematic Syntax

- Attach to a net
- Attribute Name
WIREAND
- Attribute Values
 - TRUE
 - FALSE

VHDL Syntax

Declare the VHDL constraint as follows:

```
attribute WIREAND: string;
```

Specify the VHDL constraint as follows:

```
attribute WIREAND of signal_name : signal is "{YES|NO|TRUE|FALSE}";
```

For more information about basic VHDL syntax, see [VHDL Attributes](#).

Verilog Syntax

Place the Verilog constraint immediately before the module or instantiation.

Specify the Verilog constraint as follows:

```
(* WIREAND = "{YES|NO|TRUE|FALSE}" *)
```

For more information about basic Verilog syntax, see [Verilog Attributes](#).

UCF and NCF Syntax

The following statement specifies that the net named **SIG_11** be implemented as a wired **AND** when optimized.

```
NET "$I16789/SIG_11" WIREAND;
```

XBLKNM (XBLKNM)

The XBLKNM (XBLKNM) constraint:

- Is an advanced mapping constraint.
- Assigns block names to qualifying primitives and logic elements.

If the same XBLKNM attribute is assigned to more than one instance, the software attempts to pack logic with the same block name into one or more slices. Conversely, two symbols with different XBLKNM names are not mapped into the same block. Placing the same XBLKNM constraints on instances that do not fit within one block creates an error.

Specifying identical XBLKNM attributes on FMAP symbols tells the software to group the associated function generators into a single slice. Using XBLKNM, you can partition a complete slice without constraining the slice to a physical location on the device.

Hierarchical paths are not prefixed to XBLKNM attributes, so XBLKNM attributes for different slices must be unique throughout the entire design.

The [BLKNM](#) attribute allows any elements except those with a different BLKNM to be mapped into the same physical component. XBLKNM, however, allows only elements with the same XBLKNM to be mapped into the same physical component. Elements without an XBLKNM cannot be mapped into the same physical component as those with an XBLKNM.

XBLKNM can also be used with block RAMs.

Architecture Support

Applies to FPGA devices. Does not apply to CPLD devices.

Applicable Elements

For information about which design elements can be used with which device families, see the *Libraries Guides*. For more information, see the device [data sheet](#).

Propagation Rules

Applies to the design element to which it is attached.

Syntax Examples

The following examples show how to use this constraint with particular tools or methods. If a tool or method is not listed, you cannot use this constraint with it.

Values

`block_name` is a valid block name for that type of symbol

Schematic Syntax

- Attach to a valid instance
- Attribute Name
XBLKNM
- Attribute Values
See *Values* section above.

VHDL Syntax

Declare the VHDL constraint as follows:

attribute XBLKNM: string;

Specify the VHDL constraint as follows:

attribute XBLKNM of {component_name|label_name}: {component|label} is block_name;

For more information about basic VHDL syntax, see [VHDL Attributes](#).

Verilog Syntax

Place the Verilog constraint immediately before the module or instantiation.

Specify the Verilog constraint as follows:

```
(* XBLKNM = "block_name" *)
```

For more information about basic Verilog syntax, see [Verilog Attributes](#).

UCF and NCF Syntax

```
INST "instance_name" XBLKNM=block_name;
```

The following statement assigns an instantiation of an element named **flip_flop2** to a block named **U1358**.

```
INST "$1I87/flip_flop2" XBLKNM=U1358;
```

XCF Syntax

```
BEGIN MODEL "entity_name"
```

```
INST "instance_name" xblknm=xblknm_name;
```

```
END;
```

Additional Resources

- **Xilinx Glossary** - http://www.xilinx.com/support/documentation/sw_manuals/glossary.pdf
- **Xilinx Documentation** - <http://www.xilinx.com/support/documentation>
- **Xilinx Support** - <http://www.xilinx.com/support>